

## C-Series

CENTRIFUGAL PUMPS



*Featuring Sealed Impeller Design!*



**Waukesha Cherry-Burrell®**

Versatile Waukesha C-Series Centrifugal Pumps from Waukesha Cherry-Burrell find broad application throughout sanitary and industrial processes.

These rugged pumps accommodate a wide range of solids and liquids under a variety of flow conditions and deliver long service with minimum downtime.

SPX FLOW, Inc. (NYSE:FLOW) is a leading manufacturer of innovative flow technologies, many of which help define the industry standard in the market segments they serve. From its headquarters in Charlotte, North Carolina, it operates a sales and support network, centers of manufacturing excellence, and advanced engineering facilities, throughout the world. Its cutting-edge flow components and process equipment portfolio includes a wide range of pumps, valves, heat exchangers, mixers, homogenizers, separators, filters, UHT, and drying technology that meet many application needs. Its expert engineering capability also makes it a premium supplier of customized solutions and complete, turn-key packages to meet the most exacting of installation demands.

Incorporating many leading brands, SPX FLOW has a long history of serving the food and beverage, power and energy, and industrial market sectors. Its designs and engineered solutions help customers drive efficiency and productivity, increase quality and reliability, and meet the latest regulatory demands. In-depth understanding of applications and processes, state-of-the-art Innovation Centers, and advanced pilot/testing technology further assist in optimizing processes and reducing timescales to reliably meet production targets.

To learn more about SPX FLOW capabilities, its latest technology innovations and complete service offerings, please visit [www.spxflow.com](http://www.spxflow.com).

## C-Series Centrifugal Pumps

### FEATURES AND BENEFITS

- Long-life backplate and adapters - both backplate (with O-ring) and adapters are machined from solid bar stock stainless steel for optimum casing seal life and corrosion resistance.
- Long-life components — all “wet end” components are 316L stainless steel.
- 3-A and CE certified

### MATERIAL SPECIFICATIONS

#### Materials

##### Casing:

- 316L stainless steel

##### Backplate:

- 316L stainless steel

##### Impeller:

- 316L stainless steel

##### Port Connection:

- S-Line Standard
- I-Line Female
- Bevel Seat threaded or NPT (Male or Female) are optional

##### Seal Type:

- Type D Seal, external balanced (standard)
- Type F Seal (Type D with Cascade Seal Flush)
- Type DG Seal (clamped in seal/seat)
- Type E Seal (double mechanical)

**Note: DG, F and E seal not available on C-100**

##### Rotary Seal:

- Carbon (standard)
- Silicon Carbide & Tungsten Carbide (optional)
- DG Seal Seat Material: Silicon Carbide (standard)
- Siliconized Graphite, Ceramic & Tungsten Carbide (optional)

##### Elastomers:

- Buna (standard) or Fluoroelastomer (optional)

##### Finish:

- Sanitary Polish 32Ra (150 Grit)

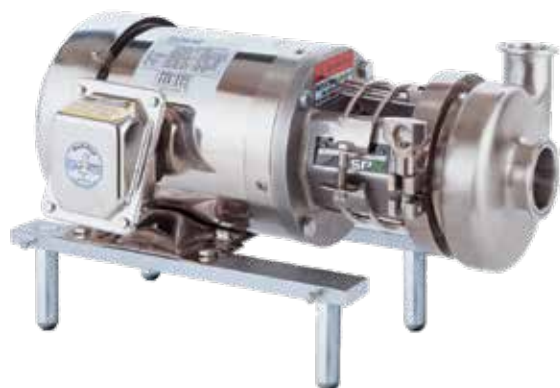

## PRODUCT SPECIFICATIONS

### Mounting:

- Pump head mounted to C-face motor; leg kit optional

### Nominal Capacity:

- To 780 GPM (177 m<sup>3</sup>/hr)

### Nominal Speed Range:

- 1450 or 2900 RPM-50HZ
- 1750 or 3500 RPM-60HZ

**Temperatures:** To 212°F (100°C)

### Motor :

- Standard C-face; 3 phase, 230/460 volts; 1750 and 3500 RPM
- TEFC and Washdown Duty, Foot Mounted
- Other motor types upon request

MODEL NUMBER	INLET INCH (MM)	OUTLET INCH (MM)	MAXIMUM IMPELLER DIAMETER INCH (MM)	MAXIMUM CAPACITY		MAXIMUM HEAD	
				1750 RPM	3500 RPM	1750 RPM	3500 RPM
C-100	1.5 (38)	1 (25)	3.68 (93)	33 GPM (7m <sup>3</sup> /hr)	73 GPM (17m <sup>3</sup> /hr)	17 ft (5mm)	55 ft (17mm)
C-114	1.5 (38)	1.5 (38)	4.0 (101)	74 GPM (17m <sup>3</sup> /hr)	148 GPM (34m <sup>3</sup> /hr)	18 ft (5mm)	74 ft (23mm)
	2 (51)			84 GPM (19m <sup>3</sup> /hr)	180 GPM (41m <sup>3</sup> /hr)	17 ft (5mm)	69 ft (21mm)
C-216	2 (51)	1.5 (38)	6.0 (152)	145 GPM (33m <sup>3</sup> /hr)	280 GPM (64m <sup>3</sup> /hr)	42 ft (13mm)	169 ft (52mm)
	2.5 (63)			168 GPM (38m <sup>3</sup> /hr)	280 GPM (64m <sup>3</sup> /hr)	42 ft (13mm)	169 ft (52mm)
C-218	2 (51)	1.5 (38)	8.0 (203)	217 GPM (49m <sup>3</sup> /hr)	300 GPM (68m <sup>3</sup> /hr)	78 ft (23mm)	317 ft (97mm)
	3 (76)			230 GPM (52m <sup>3</sup> /hr)	305 GPM (69m <sup>3</sup> /hr)	76 ft (23mm)	305 ft (93mm)
C-328	3 (63)	2 (51)	8.0 (203)	416 GPM (94m <sup>3</sup> /hr)	635 GPM (144m <sup>3</sup> /hr)	74 ft (23mm)	304 ft (93mm)
	4 (101)			460 GPM (104m <sup>3</sup> /hr)	900 GPM (204m <sup>3</sup> /hr)	76 ft (23mm)	131 ft (95mm)

## Typical product applications

### Bakery and Confectionery

Batters  
Fats & Oils  
Flavorings  
Sweeteners  
Yeast Slurry  
Syrups



### Dairy

Whey  
Cream, Milk  
Sweetened Condensed  
RO/UF Systems



### Pharmaceutical/Cosmetics

Emulsions  
Extracts  
Slurries  
Syrups  
High Purity Water  
WFI (Water for Injection)  
Dyes, Alcohols  
Essential Oils



### Chemical/Industrial

Detergents  
Dyes  
Soap Liquors & Solutions  
Ammonium Nitrate  
Propyl Alcohol  
Potassium Chloride  
Sodium Acetate



## DESIGN FEATURES

**304 stainless steel adapters** — standard, eliminate the rust, corrosion and chipping paint of conventional carbon steel adapters.

**Tested performance** — every pump passes strict testing before release for shipping.

**Longer seal life** — wave spring provides more uniform loading on seal face than single coil spring; hydraulic balancing reduces sealing surface pressures for less wear and less downtime.

**Casing matches job** — choose from standard or enlarged inlet with port connection that meets your piping system.

**Fast, easy take down** — no tools required; quick-opening, heavy-duty cast clamp secures casing; impeller pin retained by centrifugal force.

**CIP capability** — grooves in impeller/shaft routes CIP chemical solutions to all critical areas for clean-in-place.

### Pinned Impeller Design

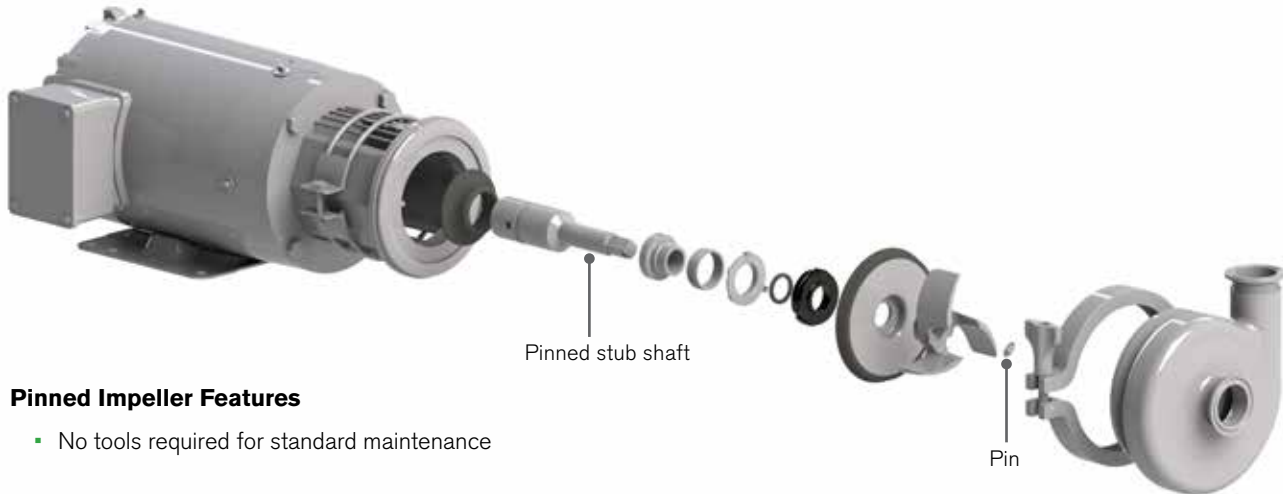

#### Pinned Impeller Features

- No tools required for standard maintenance

### Sealed Impeller Design

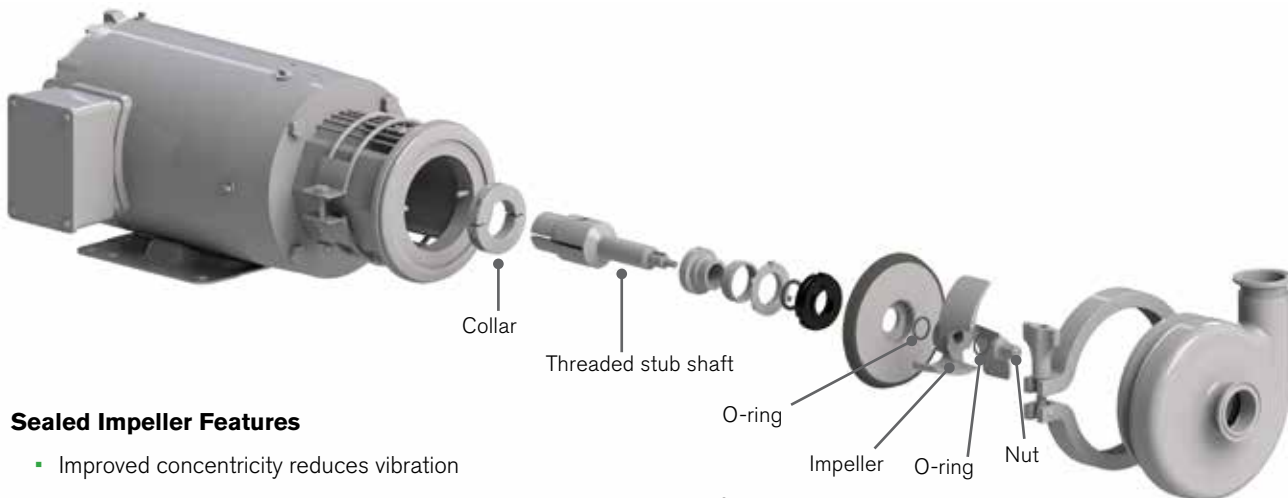

#### Sealed Impeller Features

- Improved concentricity reduces vibration
- Encapsulated dome nut eliminates wear between impeller and shaft
- Same seal options as pinned pump
- Retro kits available - EPDM and FKM elastomers standard
- More suitable design for challenging applications

**OPTIONS AND ACCESSORIES**

**Seal Options - Available for both pinned and sealed impeller designs**

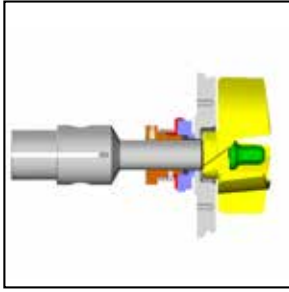

**Type D External Balanced Seal**  
 This versatile, dependable seal finds broad use in sanitary and industrial applications. Seal material is carbon rotating on the stationary stainless steel.

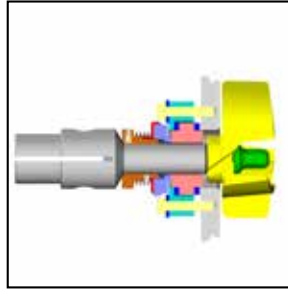

**Type DG Clamped-in Seal Seat**  
 This seal is ideal for applications where resistance to corrosion is required or for abrasive or non-lubricating products. The DG utilizes Type D rotating seal components; however, the stationary seal seat material is silicon carbide, and is reversible for extended seat life.

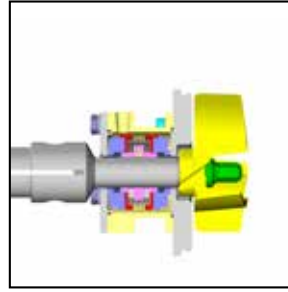

**Type E Double Mechanical Seal**  
 This double mechanical seal can be pressurized with a flush media and discharged to drain. Ideal for vacuum, high temperature, abrasive or non-lubricating applications.

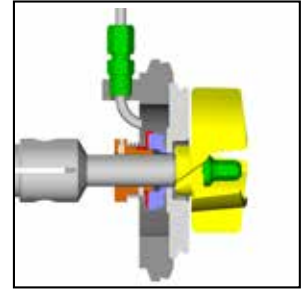

**Type F External Balanced, Water Cascade Seal**  
 When Seal Type D applications include product temperatures that reach 212°F (100°C.) or vacuum over 14" Hg (355mm Hg), seal Type F is the choice. It includes the addition of a water cascading assembly that continually flushes the seal area.

**Wave spring extends seal life**

- Wave spring maintains uniform loading on seal faces for longer seal service.

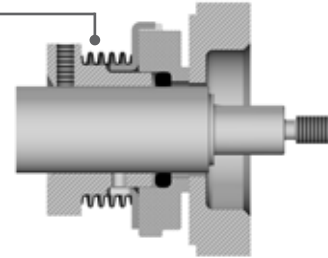

**ADDITIONAL TECHNICAL DATA**

**60 Hz**

**Pump Curves - 1750 RPM**

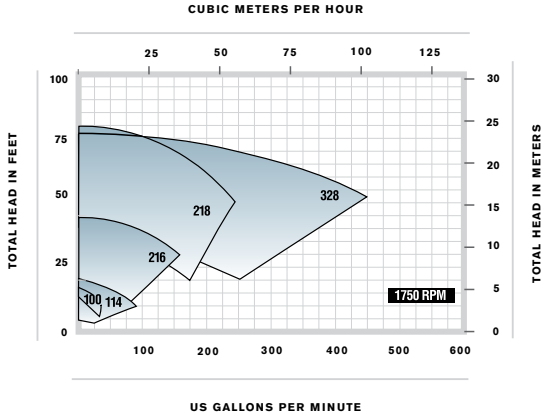

**Pump Curves - 3500 RPM**

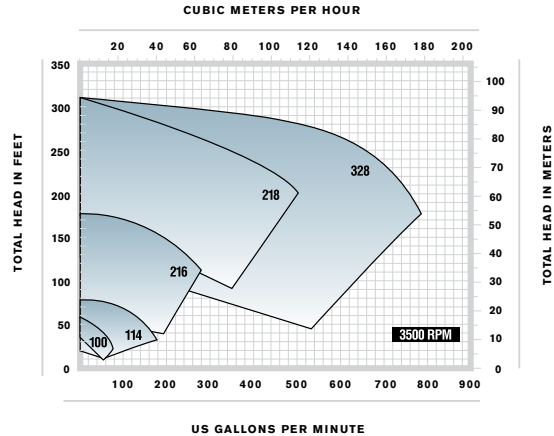

**50 Hz**

**Pump Curves - 1450 RPM**

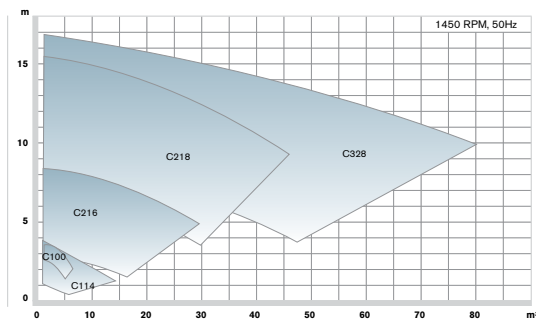

**Pump Curves - 3500 RPM**

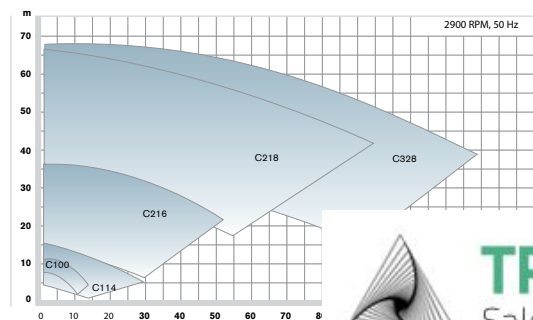

**PRODUCT DIMENSIONS - NEMA MOTOR TYPE**

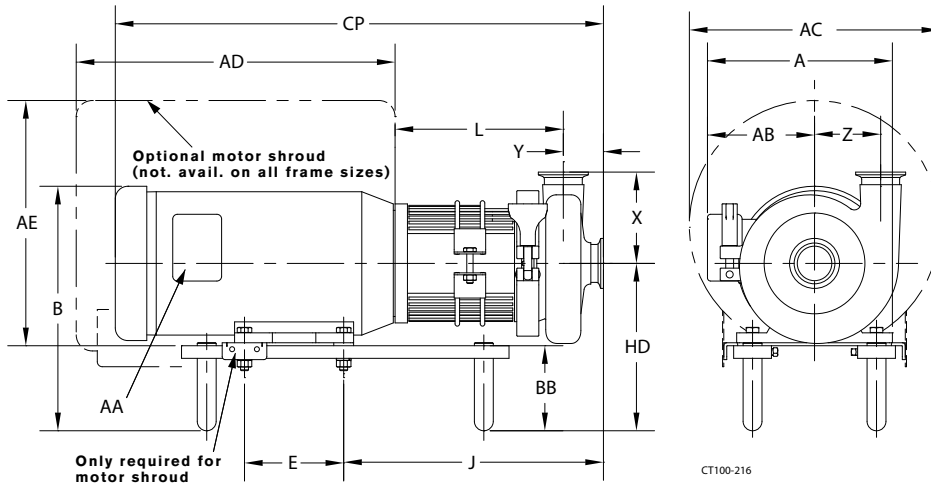

MODEL	FRAME	A IN (MM)	B IN (MM)	CP IN (MM)	J IN (MM)	E IN (MM)	L IN (MM)	HD IN (MM)	X IN (MM)	Y IN (MM)	Z IN (MM)	AA IN (MM)	AB IN (MM)
C100	56TC	6.50 (165)	9.49 (241)	17.60 (447)	6.85 (174)	2.99 (76)	2.76 (70)	5.47 (139)	3.46 (88)	1.50 (38)	1.46 (37)	0.47 (12)	3.23 (82)
	140TC	9.69 (246)	9.49 (241)	19.96 (507)	7.68 (195)	3.98 (101)	3.74 (95)	5.98 (152)	3.46 (88)	1.50 (38)	1.46 (37)	0.75 (19)	6.93 (176)
C114	56C	6.50 (165)	9.49 (241)	16.34 (415)	10.35 (263)	2.99 (76)	6.22 (158)	5.47 (139)	3.62 (92)	1.61 (41)	2.60 (66)	0.47 (12)	3.23 (82)
	140TC	9.69 (246)	9.49 (241)	19.21 (488)	10.67 (271)	5.00 (127)	6.22 (158)	5.98 (152)	3.62 (92)	1.61 (41)	2.60 (66)	0.75 (19)	6.93 (176)
	180TC	11.61 (295)	11.42 (290)	22.24 (565)	13.39 (340)	5.47 (139)	6.77 (172)	6.97 (177)	3.62 (92)	1.61 (41)	2.60 (66)	0.75 (19)	7.87 (200)
C216	56C	6.50 (165)	9.49 (241)	16.34 (415)	10.51 (267)	2.99 (76)	6.06 (154)	5.47 (139)	5.67 (144)	1.93 (49)	3.66 (93)	0.47 (12)	3.23 (82)
	140TC	9.69 (246)	9.49 (241)	19.21 (488)	10.83 (275)	5.00 (127)	6.06 (154)	5.98 (152)	5.67 (144)	1.93 (49)	3.66 (93)	0.75 (19)	6.93 (176)
	180TC	11.61 (295)	11.42 (290)	22.24 (565)	12.20 (310)	5.47 (139)	6.69 (170)	6.97 (177)	5.67 (144)	1.93 (49)	3.66 (93)	0.75 (19)	7.87 (200)
	210TC	13.11 (333)	12.91 (328)	25.79 (655)	13.94 (354)	5.98 (152)	7.80 (198)	7.72 (196)	5.67 (144)	1.93 (49)	3.66 (93)	0.75 (19)	8.86 (225)
C218	250TC	14.50 (368)	15.00 (381)	31.02 (788)	14.50 (368)	10.00 (254)	8.50 (216)	8.74 (222)	5.67 (144)	1.93 (49)	3.66 (93)	0.98 (25)	9.49 (241)
	140TC	9.69 (246)	9.49 (241)	19.21 (488)	10.98 (279)	5.00 (127)	6.30 (160)	5.98 (152)	5.47 (139)	1.93 (49)	4.72 (120)	0.75 (19)	6.93 (176)
	180TC	11.61 (295)	11.42 (290)	22.24 (565)	12.28 (312)	5.00 (127)	6.93 (176)	6.97 (177)	5.47 (139)	1.93 (49)	4.72 (120)	0.75 (19)	7.87 (200)
	210TC	13.11 (333)	12.91 (328)	25.79 (655)	13.27 (337)	5.98 (152)	7.28 (185)	7.72 (196)	5.47 (139)	1.93 (49)	4.72 (120)	0.75 (19)	8.86 (225)
	250TC	14.49 (368)	15.00 (381)	31.02 (788)	14.65 (372)	10.00 (254)	8.19 (208)	8.74 (222)	5.47 (139)	1.93 (49)	4.72 (120)	0.98 (25)	9.49 (241)
	280TC	20.63 (524)	17.28 (439)	32.24 (819)	15.28 (388)	10.98 (279)	8.82 (224)	9.49 (241)	5.47 (139)	1.93 (49)	4.72 (120)	1.97 (50)	13.11 (333)
C328	280TSC	18.58 (472)	16.30 (414)	31.93 (811)	15.28 (388)	10.98 (279)	8.82 (224)	9.49 (241)	5.47 (139)	1.93 (49)	4.72 (120)	1.97 (50)	12.20 (310)
	180TC	11.61 (295)	11.42 (290)	22.24 (565)	12.28 (312)	5.00 (127)	6.93 (176)	6.97 (177)	5.47 (139)	2.24 (57)	4.72 (120)	0.75 (19)	7.87 (200)
	210TC	13.11 (333)	12.91 (328)	25.79 (655)	13.27 (337)	5.98 (152)	7.28 (185)	7.72 (196)	5.47 (139)	2.24 (57)	4.72 (120)	0.75 (19)	8.86 (225)
	250TC	14.49 (368)	15.00 (381)	31.02 (788)	14.65 (372)	10.00 (254)	8.19 (208)	8.74 (222)	5.47 (139)	2.24 (57)	4.72 (120)	0.98 (25)	9.49 (241)
	280TC	20.63 (524)	17.28 (439)	32.56 (827)	15.93 (396)	10.98 (279)	8.82 (224)	9.49 (241)	5.47 (139)	2.24 (57)	4.72 (120)	1.97 (50)	13.11 (333)
	280TSC	18.58 (472)	16.30 (414)	32.24 (819)	15.93 (396)	10.98 (279)	8.82 (224)	9.49 (241)	5.47 (139)	1.93 (49)	4.72 (120)	1.97 (50)	12.20 (310)
	320TC	23.11 (587)	20.98 (533)	35.43 (900)	17.13 (435)	11.97 (304)	9.69 (246)	10.47 (266)	5.47 (139)	2.24 (57)	4.72 (120)	1.97 (50)	14.09 (358)
320TSC	23.11 (587)	20.98 (533)	35.43 (900)	17.13 (435)	11.97 (304)	9.69 (246)	10.47 (266)	5.47 (139)	2.24 (57)	4.72 (120)	1.97 (50)	14.09 (358)	

**PRODUCT DIMENSIONS - IEC MOTOR TYPE**

MODEL	FRAME	A IN (MM)	B IN (MM)	CP IN (MM)	J IN (MM)	E IN (MM)	L IN (MM)	HD IN (MM)	X IN (MM)	Y IN (MM)	Z IN (MM)	AA IN (MM)	AB IN (MM)	AC IN (MM)	AD IN (MM)	AE IN (MM)
C100	71-B5	4.69 (119)	7.64 (194)	14.31 (364)	6.02 (153)	3.54 (90)	6.22 (158)	5.30 (135)	3.46 (88)	1.50 (38)	1.46 (37)	0.69 (18)	4.00 (102)	9.94 (253)	12.66 (322)	9.80 (249)
C114	71-B5/B14	4.69 (119)	7.64 (194)	17.90 (455)	9.61 (244)	3.54 (90)	6.22 (158)	5.30 (135)	3.62 (92)	1.61 (41)	2.60 (66)	0.69 (18)	4.00 (102)	9.94 (253)	12.66 (322)	9.80 (249)
	80-B5/B14	5.69 (145)	8.50 (216)	19.44 (494)	6.43 (163)	3.94 (100)	6.78 (172)	5.65 (144)	3.62 (92)	1.61 (41)	2.60 (66)	0.88 (22)	4.51 (115)	9.94 (253)	12.66 (322)	10.00 (254)
	90-B5/B14	6.61 (168)	9.31 (237)	20.22 (514)	10.61 (270)	3.94 (100)	6.78 (172)	6.04 (154)	3.62 (92)	1.61 (41)	2.60 (66)	0.88 (22)	5.12 (130)	9.94 (253)	12.66 (322)	10.00 (254)
C216	80-B5/B14	5.69 (145)	8.50 (216)	19.66 (499)	10.59 (269)	3.94 (100)	6.69 (170)	5.65 (144)	5.67 (144)	1.93 (49)	3.66 (93)	0.88 (22)	4.51 (115)	9.94 (253)	12.66 (322)	10.00 (254)
	90-B5/B14	6.61 (168)	9.31 (237)	20.44 (519)	10.83 (275)	3.94 (100)	6.69 (170)	6.04 (154)	5.67 (144)	1.93 (49)	3.66 (93)	0.88 (22)	5.12 (130)	9.94 (253)	12.66 (322)	10.00 (254)
	100-B5/B14	7.87 (200)	10.41 (264)	23.28 (591)	12.23 (311)	5.51 (140)	7.81 (198)	6.44 (164)	5.67 (144)	1.93 (49)	3.66 (93)	1.06 (27)	5.87 (149)	12.11 (308)	15.53 (394)	12.20 (310)
	112-B5/B14	7.87 (200)	10.94 (278)	23.28 (591)	12.56 (319)	5.51 (140)	7.81 (198)	6.91 (176)	5.67 (144)	1.93 (49)	3.66 (93)	1.06 (27)	7.37 (187)	14.27 (363)	19.00 (483)	14.20 (361)
C218	132-B5/B14	9.56 (243)	12.56 (319)	30.26 (769)	13.94 (354)	5.51 (140)	8.50 (216)	7.70 (196)	5.67 (144)	1.93 (49)	3.66 (93)	1.06 (27)	7.38 (187)	14.27 (363)	19.00 (483)	14.20 (361)
	80-B5/B14	5.69 (145)	8.50 (216)	19.91 (506)	10.84 (275)	3.94 (100)	6.94 (176)	5.65 (144)	5.47 (139)	1.93 (49)	4.72 (120)	0.88 (22)	4.51 (115)	9.94 (253)	12.66 (322)	10.00 (254)
	90-B5/B14	6.61 (168)	9.31 (237)	20.69 (526)	11.08 (281)	3.94 (100)	6.94 (176)	6.04 (154)	5.47 (139)	1.93 (49)	4.72 (120)	0.88 (22)	5.12 (130)	9.94 (253)	12.66 (322)	10.00 (254)
	100-B5/B14	7.87 (200)	10.41 (264)	22.78 (579)	11.73 (298)	5.51 (140)	7.31 (186)	6.44 (164)	5.47 (139)	1.93 (49)	4.72 (120)	1.06 (27)	5.87 (149)	12.11 (308)	15.53 (395)	12.20 (310)
	112-B5/B14	7.87 (200)	10.94 (278)	22.78 (579)	12.06 (306)	5.51 (140)	7.31 (186)	6.91 (176)	5.47 (139)	1.93 (49)	4.72 (120)	1.06 (27)	5.87 (149)	14.27 (363)	19.00 (483)	14.20 (361)
	132-B5/B14	9.56 (243)	12.56 (319)	29.95 (761)	13.63 (346)	5.51 (140)	8.19 (208)	7.70 (196)	5.47 (139)	1.93 (49)	4.72 (120)	1.06 (27)	7.37 (187)	14.27 (363)	19.00 (483)	14.20 (361)
C328	160-B5/B14	12.94 (329)	15.44 (392)	32.66 (830)	15.88 (403)	8.27 (210)	9.69 (246)	8.80 (224)	5.47 (139)	1.93 (49)	4.72 (120)	1.38 (35)	9.51 (242)	19.00 (483)	27.11 (689)	18.50 (470)
	80-B5/B14	5.69 (145)	8.50 (216)	20.22 (514)	11.16 (284)	3.94 (100)	6.94 (176)	5.65 (144)	5.47 (139)	2.24 (57)	4.72 (120)	0.88 (22)	4.51 (115)	9.94 (253)	12.66 (322)	10.00 (254)
	90-B5/B14	6.61 (168)	9.31 (237)	21.00 (533)	11.39 (289)	3.94 (100)	6.94 (176)	6.04 (154)	5.47 (139)	2.24 (57)	4.72 (120)	0.88 (22)	5.12 (130)	9.94 (253)	12.66 (322)	10.00 (254)
	100-B5/B14	7.87 (200)	10.41 (264)	23.09 (587)	12.04 (306)	5.51 (140)	7.31 (186)	6.44 (164)	5.47 (139)	2.24 (57)	4.72 (120)	1.06 (27)	5.87 (149)	12.11 (308)	15.53 (395)	12.20 (310)
	112-B5/B14	7.87 (200)	10.94 (278)	23.09 (587)	12.37 (314)	5.51 (140)	7.31 (186)	6.91 (176)	5.47 (139)	2.24 (57)	4.72 (120)	1.06 (27)	5.87 (149)	14.27 (363)	19.00 (483)	14.21 (361)
	132-B5/B14	9.56 (243)	12.56 (319)	30.26 (769)	13.94 (354)	5.51 (140)	8.19 (208)	7.70 (196)	5.47 (139)	2.24 (57)	4.72 (120)	1.06 (27)	7.37 (187)	14.27 (363)	19.00 (483)	14.20 (361)
	160-B5/B14	12.94 (329)	15.44 (392)	32.97 (837)	16.19 (411)	8.27 (210)	9.69 (246)	8.80 (224)	5.47 (139)	2.24 (57)	4.72 (120)	1.37 (35)	9.51 (242)	19.00 (483)	27.11 (689)	18.50 (470)
	180-B5/B14	15.56 (395)	17.14 (435)	35.14 (893)	16.70 (424)	9.49 (241)	9.69 (246)	9.59 (244)	5.47 (139)	2.24 (57)	4.72 (120)	2.01 (51)	13.12 (333)	---	---	---

**IEC International Version Available**

- IEC Frame Adapter
- Hydraulic balancing reduces pressure at sealing surface for less wear
- Easy-cleaning, open type impeller delivers smooth pumping performance
- Enlarged inlets available for larger suction lines
- CIP capability standard
- 3-A and CE certified
- Special European design shroud



**SPXFLOW**

Based in Charlotte, North Carolina, SPX FLOW, Inc. (NYSE: FLOW) is a multi-industry manufacturing leader. For more information, please visit [www.spxflow.com](http://www.spxflow.com)

**SPX FLOW**

611 Sugar Creek Road

Delavan, WI 53115

P: (262) 728-1900 or (800) 252-5200

E: [wcb@spxflow.com](mailto:wcb@spxflow.com)

SPX FLOW, Inc. reserves the right to incorporate our latest design and material changes without notice or obligation.

Design features, materials of construction and dimensional data, as described in this bulletin, are provided for your information only and should not be relied upon unless confirmed in writing. Please contact your local sales representative for product availability in your region. For more information visit [www.spxflow.com](http://www.spxflow.com).

The green "y" and "x" are trademarks of SPX FLOW, Inc.

Issued: 07/2018 FH-1735

COPYRIGHT © 2018 SPX FLOW, Inc.