



Centrifugal Pumps

C-Series



Pure pumping value: Reliability + Economy

Waukesha C-Series sanitary pumps:

Versatile Waukesha C-Series Centrifugal Pumps from Waukesha Cherry-Burrell find broad application throughout sanitary and industrial processes.

These rugged pumps accommodate a wide range of solids and liquids under a variety of flow conditions and deliver long service with minimum downtime.

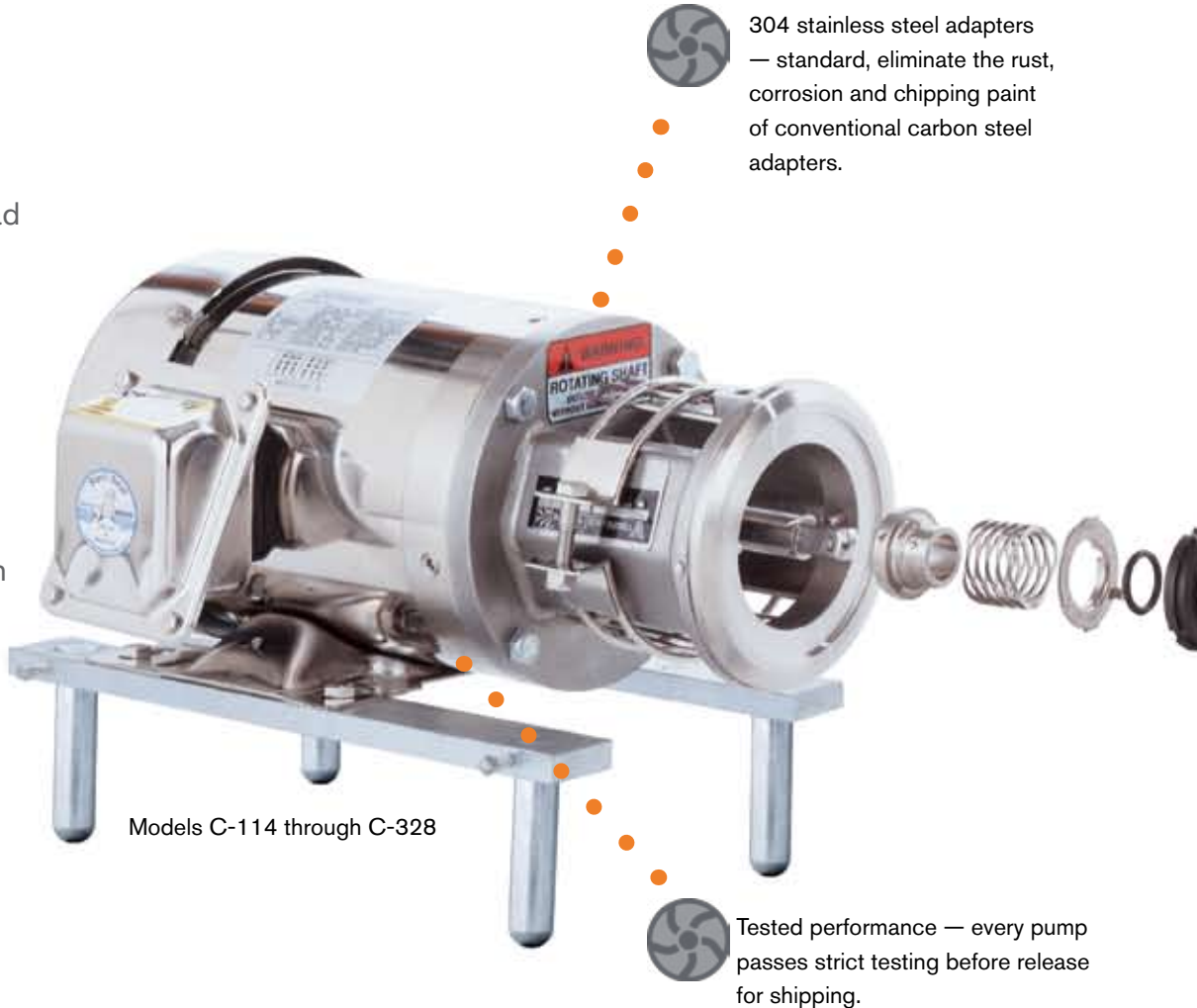

Models C-114 through C-328



304 stainless steel adapters — standard, eliminate the rust, corrosion and chipping paint of conventional carbon steel adapters.



Tested performance — every pump passes strict testing before release for shipping.

C-100 Centrifugal Pumps

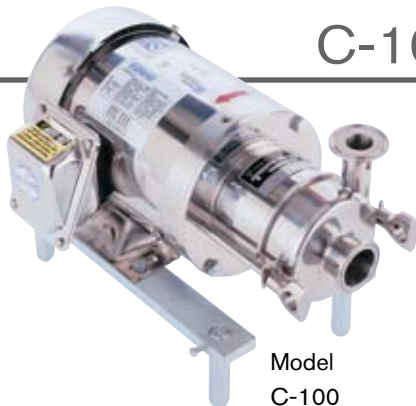

Model C-100

- Long-life backplate and adapters — both backplate (with O-ring) and adapters are machined from solid bar stock stainless steel for optimum casing seal life and corrosion resistance.
- Long-life components — all “wet end” components are 316L stainless steel.



Fast, easy takedown — no tools required; quick-opening, heavy-duty cast clamp secures casing; impeller pin retained by centrifugal force.



Longer seal life — wave spring provides more uniform loading on seal face than single coil spring; hydraulic balancing reduces sealing surface pressures for less wear and less downtime.



CIP capability — grooves-in-impeller/shaft routes CIP chemical solutions to all critical areas for clean-in-place.



Casing matches job — choose from standard or enlarged inlet with port connection that meets your piping system.

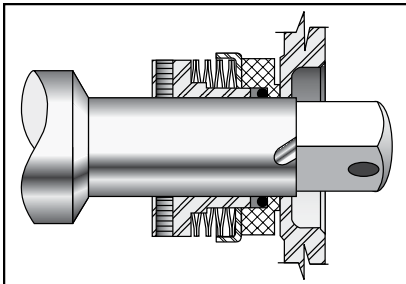

Wave spring extends seal life

Wave spring maintains uniform loading on seal faces for longer seal service.

Seal Options

Type D

External Balanced Seal
This versatile, dependable seal finds broad use in sanitary and industrial applications. Seal material is carbon rotating on the stationary stainless steel.

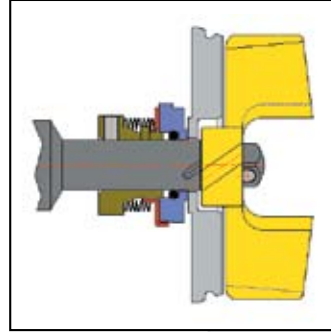

Type DG

Clamped-in Seal Seat
This seal is ideal for applications where resistance to corrosion is required or for abrasive or non-lubricating products. The DG utilizes Type D rotating seal components; however, the stationary seal seat material is silicon carbide, and is reversible for extended seat life.

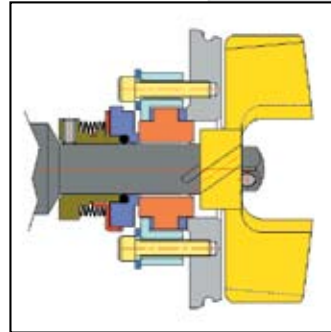

Type E

Double Mechanical Seal
This double mechanical seal can be pressurized with a flush media and discharged to drain. Ideal for vacuum, high temperature, abrasive or non-lubricating applications.

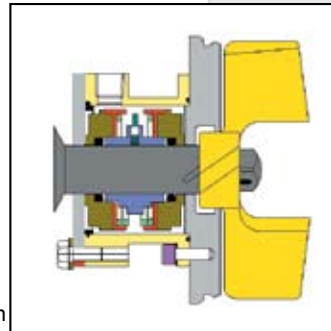

Type F

External Balanced, Water Cascade Seal
When Seal Type D applications include product temperatures that reach 212°F. (100°C.) or vacuum over 14" Hg (355mm Hg), seal Type F is the choice. It includes the addition of a water cascading assembly that continually flushes the seal area.

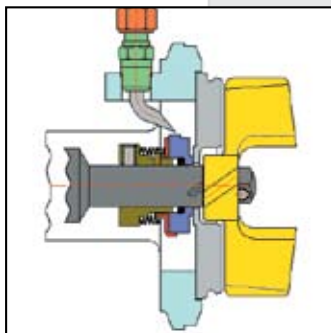

Mechanical Specifications

Standard Construction:

Casing: 316L stainless steel

Backplate: 316L stainless steel

Impeller: 316L stainless steel

Port Connection: S-Line Standard; I-Line Female, Bevel Seat threaded or NPT (Male or Female) are optional

Seal Type: Type D Seal, external balanced (standard)

Type F Seal (Type D with Cascade Seal Flush)

Type DG Seal (clamped in seal/seat)

Type E Seal (double mechanical)

Note: DG, F and E seal not available on C-100

Rotary Seal Material: Carbon (standard)

Silicon Carbide & Tungsten Carbide (optional)

DG Seal Seat Material: Silicon Carbide (standard)

Purebide, Ceramic & Tungsten Carbide (optional)

Elastomers: Buna (standard) or Fluoroelastemer (optional)

Finish: Sanitary Polish 32RA (150 Grit)

Mounting: Pump head mounted to C-face motor;

leg kit optional

Performance Characteristics:

Nominal Capacity: To 780 GPM

Temperatures: To 212°F

Nominal Speed Range: 1450 or 2900 RPM–50HZ

1750 or 3500 RPM–60HZ

Motor :

Standard C-face; 3 phase, 230/460 volts; 1750 and 3500 RPM; TEFC and Washdown Duty, Foot Mounted

Other motor types upon request

Model Number	Inlet (inches)	Outlet (inches)	Maximum Impeller Diameter (inches)
C-100	1 1/2	1	3.68
C-114	1 1/2 or 2	1 1/2	4.0
C-216	2 or 2 1/2	1 1/2	6.0
C-218	2 or 3	1 1/2	8.0
C-328	3 or 4	2	8.0

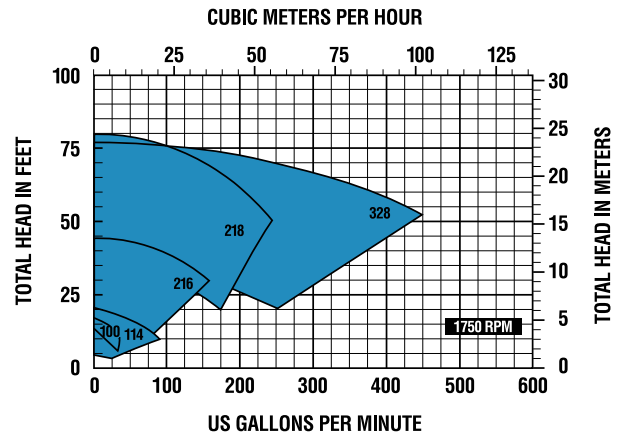
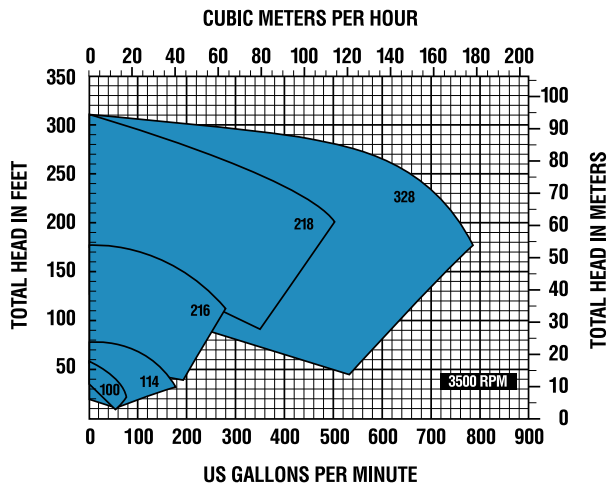

SPX Process Equipment
611 Sugar Creek Road
Delavan, WI 53115
Phone: (262) 728-1900 or (800) 252-5200 Fax: (262) 728-4904 or (800) 252-5012
Email: wcb@spx.com

For more information about our worldwide locations, approvals, certifications, and local representatives, please visit www.spxpe.com.

SPX Corporation reserves the right to incorporate our latest design and material changes without notice or obligation. Design features, materials of construction and dimensional data, as described in this bulletin, are provided for your information only and should not be relied upon unless confirmed in writing.

Issued: 04/2009 FH-1735

Copyright © 2003, 2009 SPX Corporation

SPX®

PROCESS EQUIPMENT