

Colloid Mill

FORM NO.: 95-03028 REVISION: 09/2019

READ AND UNDERSTAND THIS MANUAL PRIOR TO OPERATING OR SERVICING THIS PRODUCT.



Triplex Sales
1-847-839-8442
www.triplexsales.com

SPX FLOW, Inc.
611 Sugar Creek Road
Delavan, WI 53115

Phone: (262)728-1900 or (800)252-5200
Fax: (262)728-4904 or (800)252-5012

E-mail: wcb@spxflow.com
Website: www.spxflow.com

Information contained in this manual is subject to change without notice and does not represent a commitment on the part of SPX FLOW, Inc. No part of this manual may be reproduced or transmitted in any form or by any means, electronic or mechanical, including photocopying and recording, for any purpose, without the express written permission of SPX FLOW, Inc.

Copyright © 2019 SPX FLOW, Inc.
All Rights Reserved.

Revision Date: 09/2019

Publication: 95-03028



Table of Contents

Warranty	4
Shipping Damage or Loss.....	4
Warranty Claim	4
Safety	5
Warnings and Replacement Labels	6
Introduction/Specifications.....	6
Specifications.....	6
Colloid Mill Unit Dimensions	7
Installation and Start-Up.....	8
Variation of inlet port	8
Overhead equipment	8
Wiring.....	8
Rotation.....	8
Seal flush.....	8
Lubrication	9
Method of feeding and capacity	9
Colloid Mill Troubleshooting.....	9
Maintenance	10
Cleaning.....	10
Flushing	10
Disassembly.....	10
Assembly	12
Adjustment and Calibration	12
Flush Water Seal Replacement	13
Gear Case Service.....	14
Service Preparation	14
Front Seal Replacement.....	14
Rear Seal Replacement	14
Bearing Replacement.....	14
Sanitary Seal Replacement	15
Parts List.....	16
Colloid Mill Gear Case	16
Colloid Mill Fluid Head	18
Sanitary Seal.....	20

Warranty

LIMITED WARRANTY: Unless otherwise mutually agreed to in writing, (a) SPX FLOW US, LLC (SPX FLOW) goods, auxiliaries and parts thereof are warranted to the Buyer against defective workmanship and material for a period of twelve (12) months from date of installation or eighteen (18) months from date of delivery, whichever expires first, and (b) SPX FLOW services are warranted to Buyer to have been performed in a workmanlike manner for a period of ninety (90) days from the date of performance. If the goods or services do not conform to the warranty stated above, then as Buyer's sole remedy, SPX FLOW shall, at SPX FLOW's option, either repair or replace the defective goods or re-perform defective services. If Buyer makes a warranty claim to SPX FLOW and no actual defect is subsequently found, Buyer shall reimburse SPX FLOW for all reasonable costs which SPX FLOW incurs in connection with the alleged defect. Third party goods furnished by SPX FLOW will be repaired or replaced as Buyer's sole remedy, but only to the extent provided in and honored by the original manufacturer's warranty. Unless otherwise agreed to in writing, SPX FLOW shall not be liable for breach of warranty or otherwise in any manner whatsoever for: (i) normal wear and tear; (ii) corrosion, abrasion or erosion; (iii) any good or services which, following delivery or performance by SPX FLOW, has been subjected to accident, abuse, misapplication, improper repair, alteration (including modifications or repairs by Buyer, the end customer or third parties other than SPX FLOW), improper installation or maintenance, neglect, or excessive operating conditions; (iv) defects resulting from Buyer's specifications or designs or those of Buyer's contractors or subcontractors other than SPX FLOW; or (v) defects resulting from the manufacture, distribution, promotion or sale of Buyer's products; (vi) damage resulting from the combination, operation or use with equipment, products, hardware, software, firmware, systems or data not provided by SPX FLOW, if such damage or harm would have been avoided in the absence of such combination, operation or use; or (vii) Buyer's use of the goods in any manner inconsistent with SPX FLOW's written materials regarding the use of such product. In addition, the foregoing warranty shall not include any labor, dismantling, re-installation, transportation or access costs, or other expense associated with the repair or replacement of SPX FLOW goods. THE WARRANTIES CONTAINED HEREIN ARE THE SOLE AND EXCLUSIVE WARRANTIES AVAILABLE TO BUYER AND SPX FLOW HEREBY DISCLAIMS ANY OTHER WARRANTIES, EXPRESS OR IMPLIED, INCLUDING WITHOUT LIMITATION THE IMPLIED WARRANTIES OF MERCHANTABILITY AND FITNESS FOR A PARTICULAR PURPOSE, ANY PERFORMANCE OR PROCESS OUTCOME DESIRED BY THE BUYER AND NOT SPECIFICALLY AGREED TO BY SPX FLOW. THE FOREGOING REPAIR, REPLACEMENT AND REPERFORMANCE OBLIGATIONS STATE SPX FLOW'S ENTIRE AND EXCLUSIVE LIABILITY AND BUYER'S EXCLUSIVE REMEDY FOR ANY CLAIM IN CONNECTION WITH THE SALE AND FURNISHING OF SERVICES, GOODS OR PARTS, THEIR DESIGN, SUITABILITY FOR USE, INSTALLATION OR OPERATIONS.

Shipping Damage or Loss

If equipment is damaged or lost in transit, file a claim at once with the delivering carrier. The carrier has a signed Bill of Lading acknowledging that the shipment has been received from SPX FLOW in good condition. SPX FLOW is not responsible for the collection of claims or replacement of materials due to transit shortage or damages.

Warranty Claim

Warranty claims must have a Returned Material Authorization (RMA) from the Seller or returns will not be accepted. Contact 800-252-5200 or 262-728-1900.

Claims for shortages or other errors must be made in writing to Seller within ten (10) days after delivery. This does not include transit shortage or damages. Failure to give such notice shall constitute acceptance and waiver of all such claims by Buyer.

Safety

READ AND UNDERSTAND THIS MANUAL PRIOR TO INSTALLING, OPERATING, OR SERVICING THIS EQUIPMENT

SPX FLOW recommends users of our equipment and designs follow the latest Industrial Safety Standards. At a minimum, these should include the industrial safety requirements established by:

1. Occupational Safety and Health Administration (OSHA)
2. National Fire Protection Association (NFPA)
3. National Electrical Code (NEC)
4. American National Standards Institute (ANSI)

⚠ WARNING *Severe injury or death can result from electrical shock, burn, or unintended actuation of equipment. Recommended practice is to disconnect and lockout industrial equipment from power sources, and release stored energy, if present. Refer to the National Fire Protection Association Standard No. NFPA70E, Part II and (as applicable) OSHA rules for Control of Hazardous Energy Sources (Lockout-Tagout) and OSHA Electrical Safety Related Work Practices, including procedural requirements for:*

- Lockout-tagout
- Personnel qualifications and training requirements
- When it is not feasible to de-energize and lockout-tagout electrical circuits and equipment before working on or near exposed circuit parts

Before putting SPX FLOW equipment into operation, the operator shall analyze the application for all foreseeable risks, their likelihood to occur and the potential consequences of the identified risks as per ISO 31000 and ISO/IEC 31010 in their actual current version.

Locking and Interlocking Devices: These devices should be checked for proper working condition and capability of performing their intended functions. Make replacements only with the original equipment manufacturer's OEM renewal parts or kits. Adjust or repair in accordance with the manufacturer's instructions.

Periodic Inspection: Equipment should be inspected periodically. Inspection intervals should be based on environmental and operating conditions and adjusted as indicated by experience. At a minimum, an initial inspection within 3 to 4 months after installation is recommended. Inspection of the electrical control systems should meet the recommendations as specified in the National Electrical Manufacturers Association (NEMA) Standard No. ICS 1.3, Preventative Maintenance of Industrial Control and Systems Equipment, for the general guidelines for setting-up a periodic maintenance program.

Replacement Equipment: Use only replacement parts and devices recommended by the manufacturer to maintain the integrity of the equipment. Make sure the parts are properly matched to the equipment series, model, serial number, and revision level of the equipment.

Warnings and cautions are provided in this manual to help avoid serious injury and/or possible damage to equipment:

⚠ DANGER *Immediate hazards which WILL result in severe personal injury or death.*

⚠ WARNING *Hazards or unsafe practices which COULD result in severe personal injury or death.*

⚠ CAUTION *Hazards or unsafe practices which COULD result in minor personal injury or product or property damage.*

Warnings and Replacement Labels

⚠ WARNING Stop Machinery to Clean, Service or Repair. To avoid serious injury, do not install or service the mill unless all power is off and locked out.

⚠ WARNING To avoid electrocution, ALL electrical should be done by a registered Electrician, following Industry Safety Standards. All power must be OFF and LOCKED OUT.

⚠ WARNING To avoid possible serious injury, shut off and drain product from mill prior to disconnecting the piping.

⚠ CAUTION Mill parts have sharp edges. To avoid a cutting injury, wear gloves and handle parts carefully.



Replacement Label 33-62

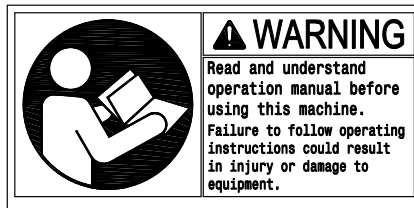

Replacement Label 121694+



Replacement label 33-61

Introduction/Specifications

The Waukesha Cherry-Burrell brand Colloid Mill produces controlled, highly sheared, uniform dispersions and stable emulsions made up of uniform globules of moderate fineness.

A serrated conical stator and a serrated rotating cone make up the emulsifying head.

Operating clearance can be adjusted in .001-inch increments between .010 and .240 inches.

Capacities range from 6.7 to 33.3 gpm (25 to 126 l/m).

Viscosity range is limited only by the maximum 150 psi feed pressure.

Specifications

Model	Nominal Speed	Pressure	Nominal Capacity To	Inlet Outlet	Nominal Temp. Range
CM	3600 RPM	to 150 psi (10 bar)	6.7 to 33.3 GPM (25 to 126 l/m)	2" San. IMDA	to 200° (93° C)

Colloid Mill Unit Dimensions

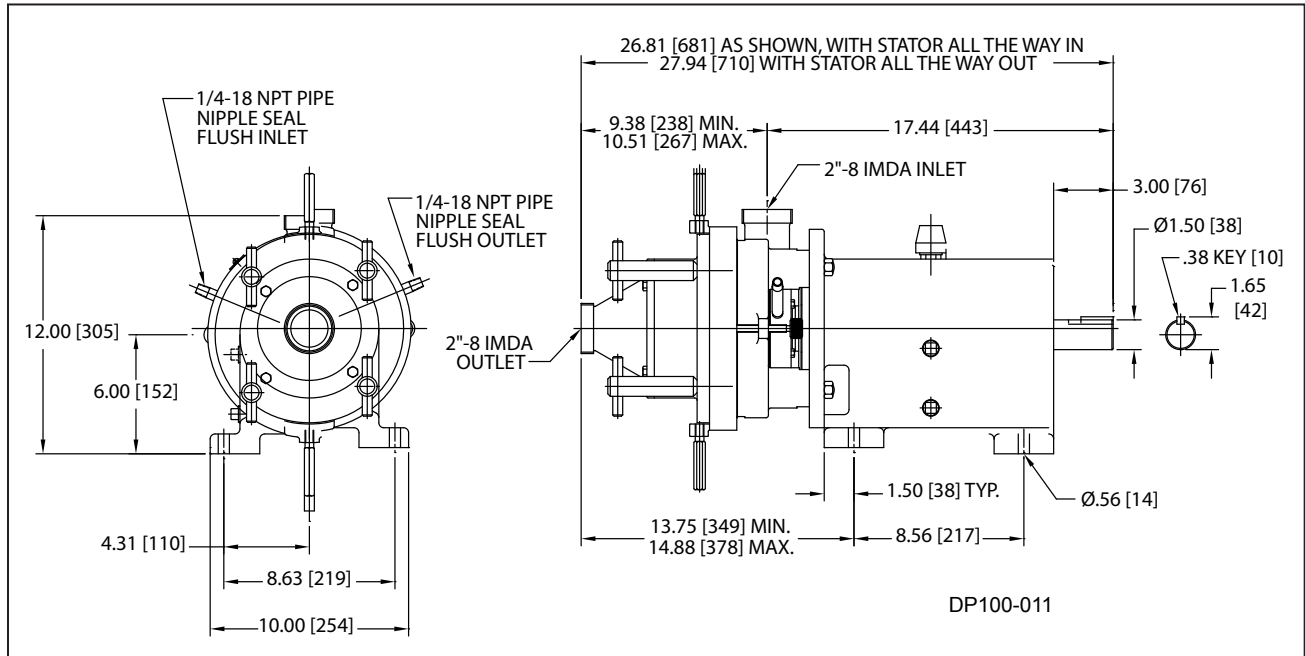

Figure 1

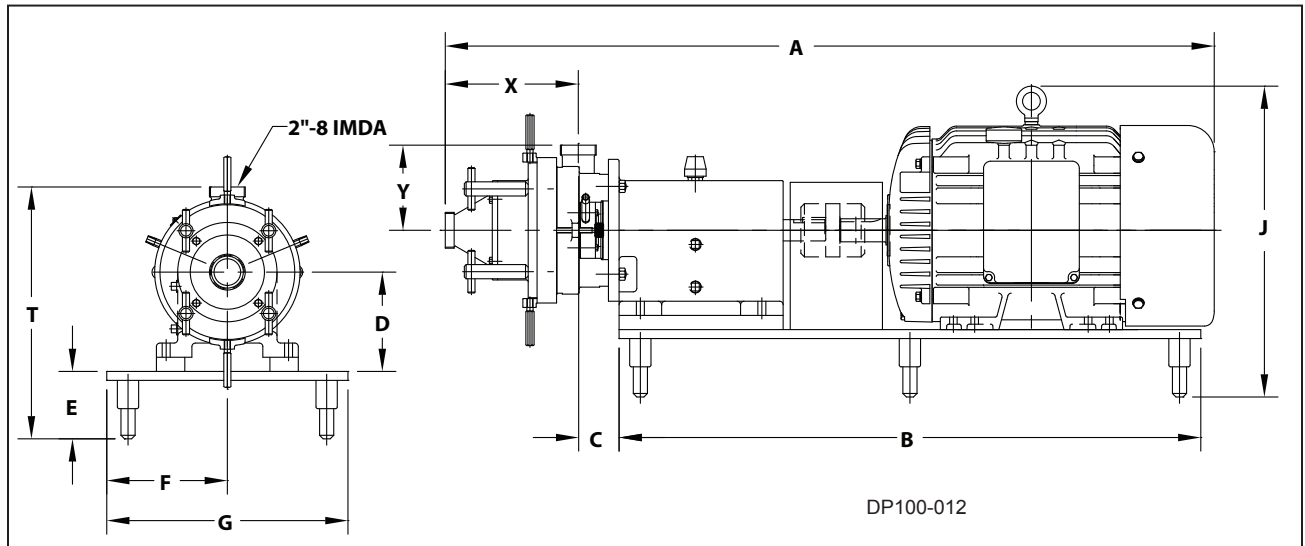

Figure 2

Unit Size	A	B	C	D	E	F	G	J	T	X	Y
15 HP	51.57 (1310)	41.00 (1041)	2.88 (73)	6.25 (159)	4.75 (121)	8.50 (216)	17.00 (432)	17.69 (449)	17.00 (432)	9.40 (239)	6.00 (152)
20 HP	53.32 (1354)	41.00 (1041)	2.88 (73)	6.25 (159)	4.75 (121)	8.50 (216)	17.00 (432)	17.69 (449)	17.00 (432)	9.40 (239)	6.00 (152)
25 HP	54.20 (1377)	41.00 (1041)	2.88 (73)	7.00 (178)	4.75 (121)	8.50 (216)	17.00 (432)	21.90 (556)	17.00 (432)	9.40 (239)	6.00 (152)

Dimensions shown in IN (mm)

NOTE: The pump is shimmed to "D" height.

Installation and Start-Up

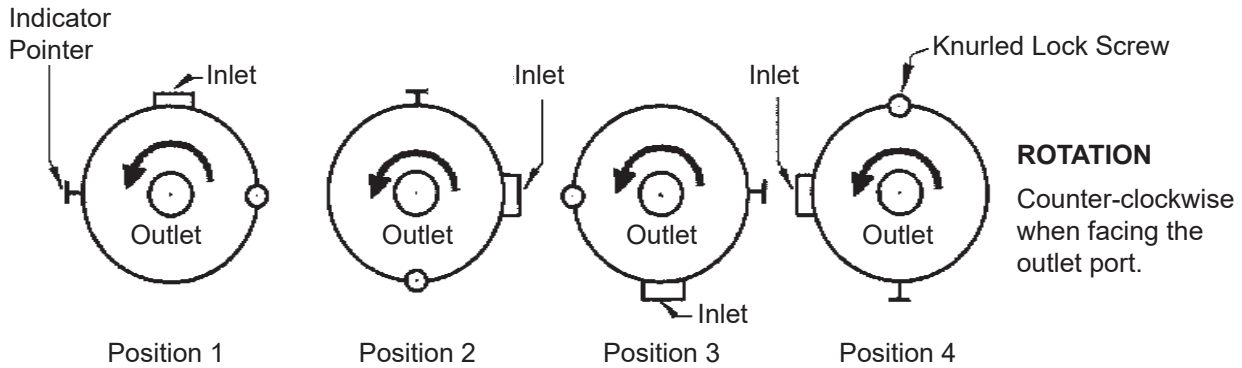

Figure 3

Variation of inlet port

See Figure 3. The mill is shipped from the factory with the inlet port as shown in Position 1. For convenience, the inlet port can be relocated to any of the other three positions (see Disassembly Procedure). If Position 4 is used the calibrations at the pointer will be upside down. We suggest the use of a mirror.

Overhead equipment

Follow accepted engineering practice when connecting the inlet and outlet with the overhead equipment, piping, or tubing. Use hangers to eliminate any weight, stress or strain on the mill. Remember, if a direct connection is made with any overhead tank, install expansion joints in the line. This will prevent mechanical loads on the mill which would damage it or affect its operation.

Wiring

3 Phase, 60 Cycle, 230-460 Volts. Follow the wiring directions on the motor. Check the direction of rotation.

Rotation

The rotation direction is counter-clockwise when facing the outlet port. If run clockwise, the rotor retaining nut may back off, resulting in damage to the mill.

Seal Flush

The mill is equipped with a face type seal which must be water cooled. The **IN** and **OUT** ports for introducing the water to the seal are located in the gland.

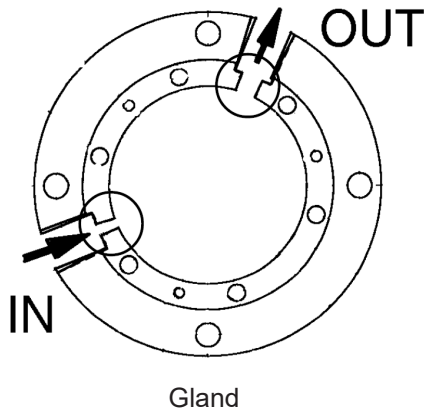

Figure 4

NOTE: These are 1/4-inch pipe nipples, but the IN hole is smaller than the OUT hole to prevent over-pressurizing (Figure 4).

The **IN** port must be used and the flow of water must be throttled to produce a **flush of 0.125 to 0.25 gpm (0.47 to 0.95 l/m)**. Flows in this range provide safe cooling without damage to the lip seal.

Recommendation: use a solenoid valve in the water line to turn on the water simultaneously with the mill. If the solenoid valve is not used, turn on the water flush line before starting the mill.

Lubrication



Figure 5

The mill is shipped with oil in the bearing case. The level should be checked at the oil level hole and if necessary, oil should be added through the oil fill hole.

Use Mobil oil DTE BB ISO Grade 220 R & O (Rust inhibited) gear oil. If DTE BB is not available, use S.A.E. 40 non-detergent mineral oil. The mill is shipped with a solid cap screw in the oil fill hole. This should be removed and replaced with the breather cap which is wired to the mill.

Frequency of lubrication is dependent upon temperature and moisture conditions. If the room temperature is normal, 70° to 80° F (21° C to 27° C), and water does not contact the bearing case, change the oil every 240 operating hours. When the temperature varies from hot to cold or the mill is flushed out with water, condensation will occur in the bearing case, requiring more frequent oil changes. Normal operating temperature of the bearing case is 170° to 190° F (77° C to 88° C).

Method of feeding and capacity

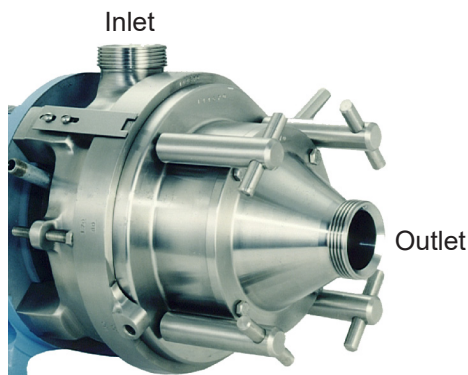

Figure 6

The inlet and outlet ports are 2 inch sanitary male threads. The inlet port is located in the body—its position can be changed. (See Figure 3 on page 8.) The outlet port is located in the cover of the mill. The mill must be fed with a pump; a Waukesha Cherry-Burrell brand positive displacement pump is recommended. The capacity of the mill is 6.7 to 33.3 gpm (25 to 126 l/m).

Colloid Mill Troubleshooting

Problem	Likely Cause	Solution(s)
Seals leaking	Exceeding 150 PSI pressure limitation of pump	Open up gap reduce pressure
	Seal flush water improperly plumbed	Connect flush water to IN/OUT ports as stamped on gland
	Water pressure too high	Adjust to 0.125 to 0.25 gpm (0.47 to 0.95 l/m)
	Seals misaligned on pin	Re-align seals to proper fit.
Noisy operation / Excessive power draw	Loose rotor nut causing rotor to stator contact	Tighten nut to 75 ft-lb. Check mill rotation (counterclockwise facing outlet port)
Inconsistent milling results	Loose adjusting ring	Set gap and tighten knurled screw in hole. Tighten bolt and nut on opposite side.
	Worn rotor or stator	Replace worn parts

Maintenance

Cleaning

CAUTION Handle all parts carefully to avoid nicks and scratches which will be detrimental to the operation of the mill.

Flushing

In some instances the unit can be cleaned by flushing water through it while the mill is in operation. However, some of the water will remain in the bottom of the cone-shaped stator. If this is not acceptable, dismantle the unit for cleaning.

Disassembly

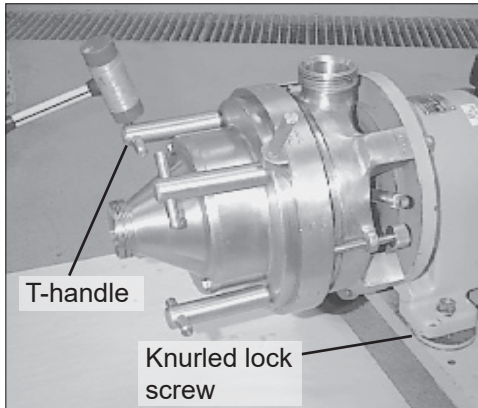

Figure 7

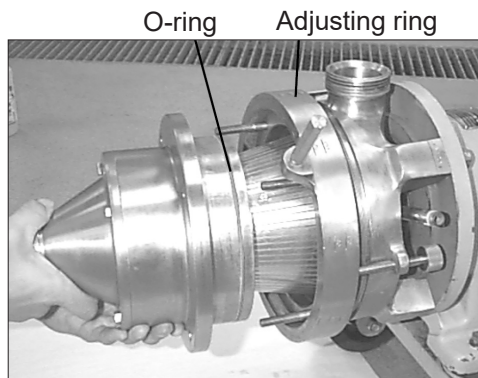

Figure 8

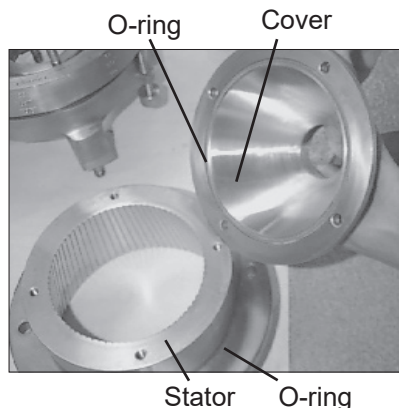

Figure 9

1. Remove the “T” handles.
2. Back out the knurled lock screw.

3. Pull the cover/stator assembly outward.

NOTE: You will experience some resistance to the stator movement due to friction from the O-ring.

As soon as the O-ring is free, the cover and stator assembly can be easily removed. It is not necessary to remove the adjusting ring. Disassembly to this point allows complete drainage.

NOTE: To prevent wearing of the faces between the adjusting ring and stator, lubricate these surfaces occasionally with an approved silicone-type lubricant.

4. Remove the cover capscrews and pull off the cover, then remove the O-ring.
5. Pull the stator off the studs and remove the O-ring.

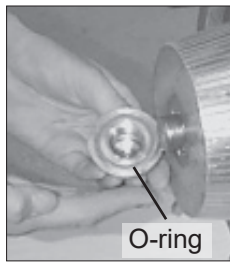

Figure 10

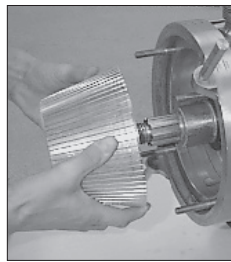

Figure 11

6. Remove the rotor retaining nut, then remove the O-ring from the nut. (See Figure 10.)
7. Slide the rotor off the shaft, making sure to handle it with care to avoid damage to the rotor or to the seal seat, which is contained in the rotor. (See Figure 11.)

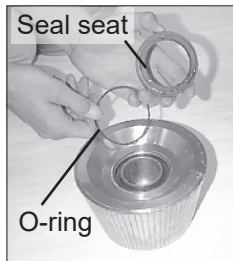

Figure 12

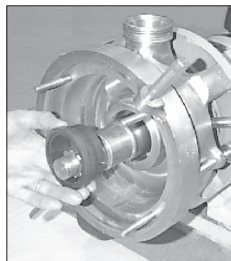

Figure 13

8. Gently pull the seal seat from the back of the rotor and remove the O-ring. (See Figure 12.)
9. Remove the seal assembly from the shaft. (See Figure 13.)

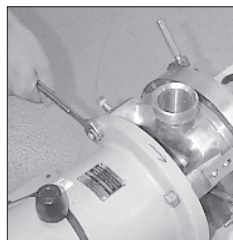

Figure 14

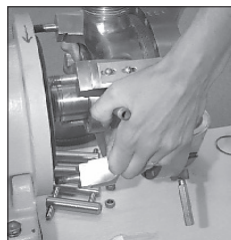

Figure 15

10. Remove the four 1/2-13 hex nuts which secure the body to the bearing case and slide the body forward off the shaft. (See Figure 14 and Figure 15.)

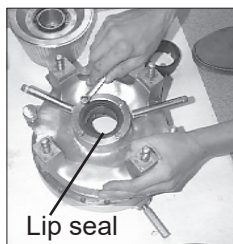

Figure 16

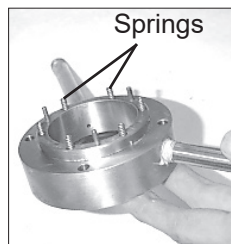

Figure 17

11. Remove the four capscrews from the gland on the back side of the body and disassemble the gland.

NOTE: There are six loose springs in the gland.

The gland lip seal can be pressed out if replacement is required. (See Figure 16 and Figure 17.)

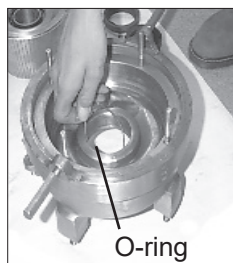

Figure 18

12. Remove the O-ring from inside the body. Use the O-ring removal tool (part no. AD0096001) if necessary. (See Figure 18.)

NOTE: Clean and inspect all parts thoroughly. DO NOT reuse the seal or seal seat if it is scratched, chipped or worn.

Assembly

Small (1/8") hole
(IN)

Large (1/4") hole
(OUT)

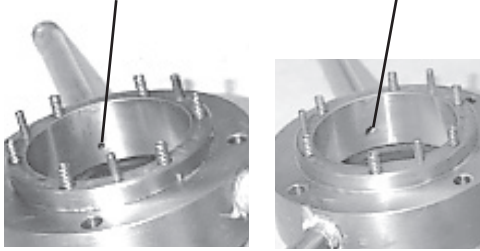

Figure 19 - Water flush system

1. Apply a suitable lubricant to all O-rings and insert them in their respective grooves.
NOTE: Place the seal seat O-ring over the seal seat and then insert the seat into the rotor.
2. Follow the disassembly procedure in reverse order to complete assembly. Torque the rotor nut to approximately 75 ft-lb (102 N·m).
3. The seal water to the mill must be connected to the gland connection marked IN (the ports are stamped "IN" and "OUT"). The inlet of the gland contains the smaller (1/8") hole. The outlet contains the larger (1/4") hole. (See Figure 19).

CAUTION Flushing backwards can cause seal leakage and flush media will enter the product zone.

Adjustment and Calibration

Locking holes

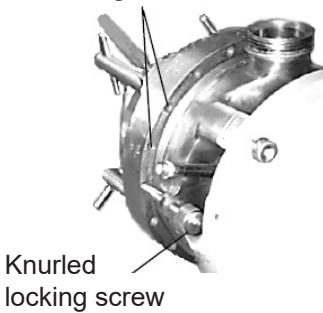

Knurled
locking screw

Figure 20

The mill can be adjusted to have a clearance between the rotor and the stator from a minimum of 0.010" (0.254 mm) to a maximum of 0.240" (6.1 mm), in increments of 0.001" (0.025 mm).

The body and the adjusting ring are calibrated as a unit and serialized; they must not be interchanged with other Waukesha Cherry-Burrell brand Colloid Mills.

The stator is held firmly against the adjusting ring by "T" handles (Figure 21).

Adjust the clearance between the rotor and stator by turning the adjusting ring counter-clockwise (when facing the outlet port) to increase the clearance, and clockwise to decrease the clearance.

The adjusting ring is engraved with numerals indicating the clearance in increments of 0.010" (0.254 mm). The indicator pointer indicates the desired clearance. For setting in between the increments of 0.010" (0.254 mm), the drill point spacing is equal to 0.001" (0.025 mm) clearance. The drill point spacing coincides with the locking hole spacing. There are 18 locking holes in the ring, spaced 20° apart (Figure 20).

Rotating the ring by 20° (hole to hole distance) changes the milling clearance by 0.001" (0.025 mm).

Example: to obtain 0.014" radial clearance, locate the 0.010 punch mark under the pointer. Turn the ring counterclockwise four additional drill points (or locking holes), and lock it in place with the knurled lock screw (Figure 20). Tighten the "T" handles to firmly hold the stator against the adjusting ring. The clearance will be 0.014" (0.36 mm). Adjust the lock bolt and tighten the nut (Figure 21).

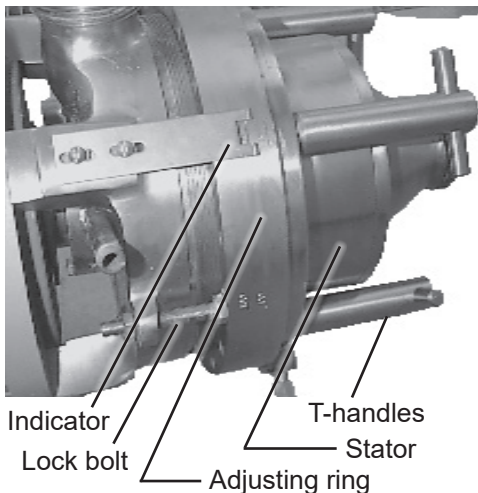

Figure 21

Flush Water Seal Replacement

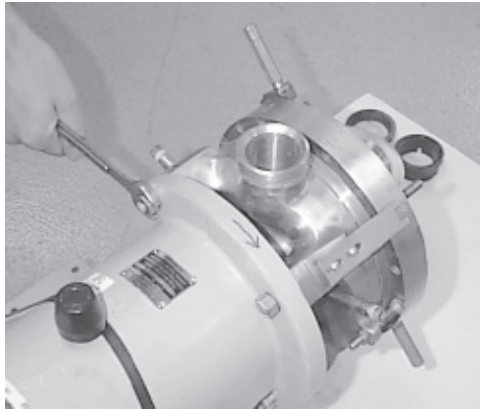

Figure 22 - Remove body nuts (4)

1. Disassemble as described in “Disassembly” on page 10.
2. Remove the four body nuts (Figure 22).



Figure 23 - Remove body

3. Slide the body forward off the shaft (Figure 23).

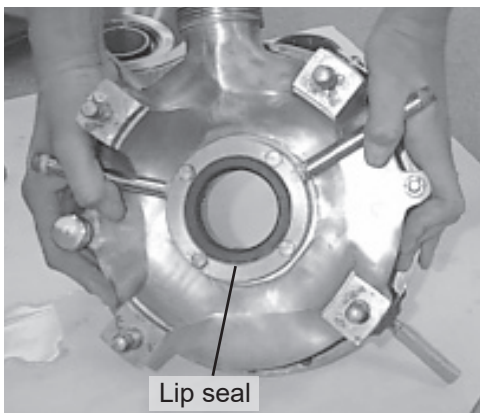

Figure 24 - Replace lip seal

4. Pull the seal out with a hook tool. Insert a new water lip seal with the lip facing in. (See item 18 in Figure 29 on page 15.)
5. Re-assemble in reverse order.

Gear Case Service

CAUTION To avoid a cutting injury, wear gloves and handle parts carefully.

Tools required for seal and/or bearing replacement:

- Assorted hand tools including soft hammer.
- Bearing puller or press.
- Hook tool for seal removal.
- Spanner wrench for bearing retainer nut removal
- Rotor Nut Wrench part no. GD0019000
- Anti-seize compound and seal lubricating grease.
- 2 quarts DTE BB Mobil oil or equivalent.

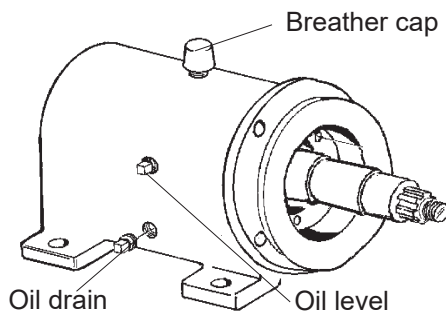

Figure 25

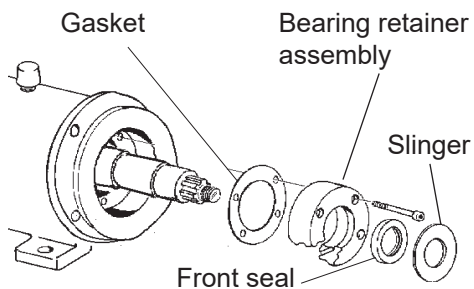

Figure 26

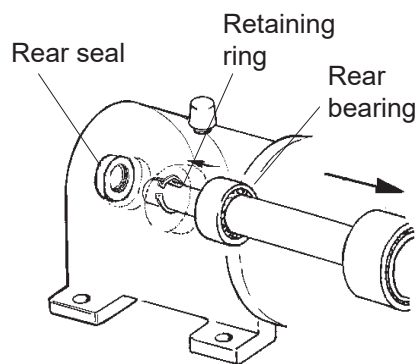

Figure 27

Service Preparation

1. Shut OFF and lock out all power.
2. Remove all product and flushing from the mill.
3. Disconnect all piping to the mill.
4. Remove the pump anchor screws and slide the gearcase off the motor coupling.
5. Place the mill on a sturdy work surface.
6. Disassemble the wet end of the mill completely. (See "Disassembly" on page 10.)
7. Drain the oil from the gear case (Figure 25).

Front Seal Replacement

1. See Figure 26. Pull off the slinger.
2. Remove the four capscrews, then remove the bearing retainer assembly (front seal inside).
3. Note the seal lip position and knock out the old seal
4. Place lubrication around the new seal and press it into the bearing retainer. Replace the gasket, if necessary. Lubricate the seal lip and install the bearing retainer and slinger.

Rear Seal Replacement

1. See Figure 27. Pull the rear oil seal off the drive shaft with a hooked tool.
2. Place tape over the shaft keyway and install a new seal. (Lubricate the seal lip before sliding it onto the shaft.)

Bearing Replacement

1. Remove the rear seal. Remove the rear bearing retaining ring. Press the drive shaft out through the front of the gear case (through the rear bearing) (Figure 27).
2. Remove the bearing locknut from the shaft (counter-clockwise) and press off the front bearing (Figure 26).
3. Press the rear bearing out of the front of the gear case (Figure 27).

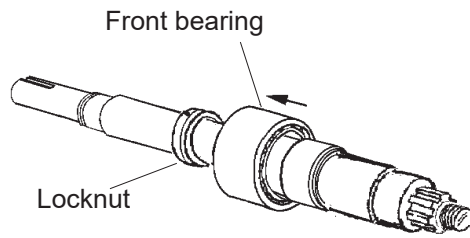

Figure 28

4. Clean and lubricate all parts thoroughly before reassembling.
NOTE: Do not unwrap the new bearings until ready to install.
5. Lubricate the inner races and press the new bearings onto the shaft. Tighten the locknut on the front bearing to 40 ft-lb (54 N·m) (Figure 28).
6. Lubricate the outer races and press the shaft assembly into the case. Replace the retaining ring and rear seal (Figure 24).
7. Replace the mill assemblies. Torque the rotor nut to 75 ft-lb (102 N·m). Refill the crankcase with 2 quarts of Mobil DTE BB oil.

Sanitary Seal Replacement

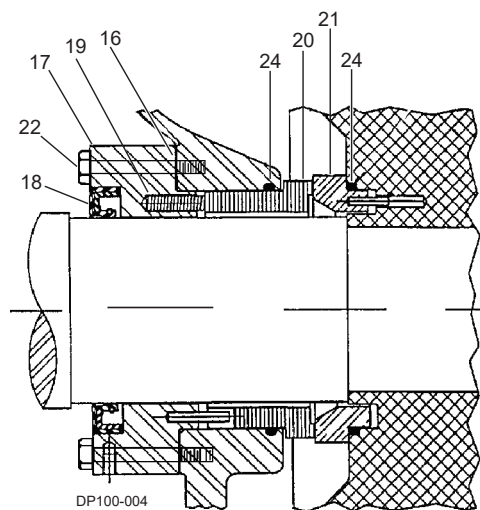

Figure 29

Item No.	Description
16	Gland Gasket
17	Gland Plate
18	Gland Plate Lip Seal
19	Spring
20	Stationary Seal
21	Rotating Seat
22	Capscrew
24	Seal Seat & Body O-ring

NOTE: Use care at all times to avoid chipping or scratching the seal or seat. Keep the seal face areas clean and dry.

1. See Figure 29. Install the gland plate lip seal (18) into the rear of the gland plate (17).
2. Apply a small amount of sealant to one end of each of the six springs (19) and place them in the gland spring holes (17).
3. Install the gasket (16) to the sealing face of the gland plate (17).
4. Attach the gland plate (17) to the mill body using the existing capscrews.
5. Install one O-ring (24) into the groove in the mill body.
6. Attach the body to the bearing case (using 4 nuts).
7. Lubricate the O-ring (24) and small O.D. of the seal (20) with a compatible lubricant. Install the seal into the mill, aligning the notches on the seal with the pins in the gland plate.
NOTE: Avoid grease-type lubricants which can harden and bind the seal; use food-grade lubricant when processing food products.
8. Lubricate the remaining O-ring (24) with a compatible lubricant and install it on the small O.D. of the seat (21).
9. Install the seat (21) (with pins and O-ring) into the rear of the rotor, aligning the pins with the holes in the rotor.
10. Install the rotor onto the shaft, being careful to avoid damage to the seat (21) or seal (20). Tighten the rotor nut to 75 ft-lb (102 N·m).
11. Complete the mill assembly. (Reverse steps 2 and 3 on page 13.)

NOTE: See page 20 for part numbers.

Parts List

Colloid Mill Gear Case

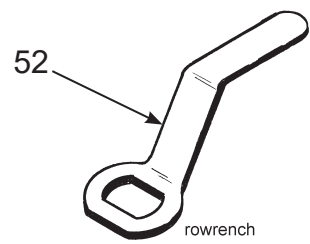
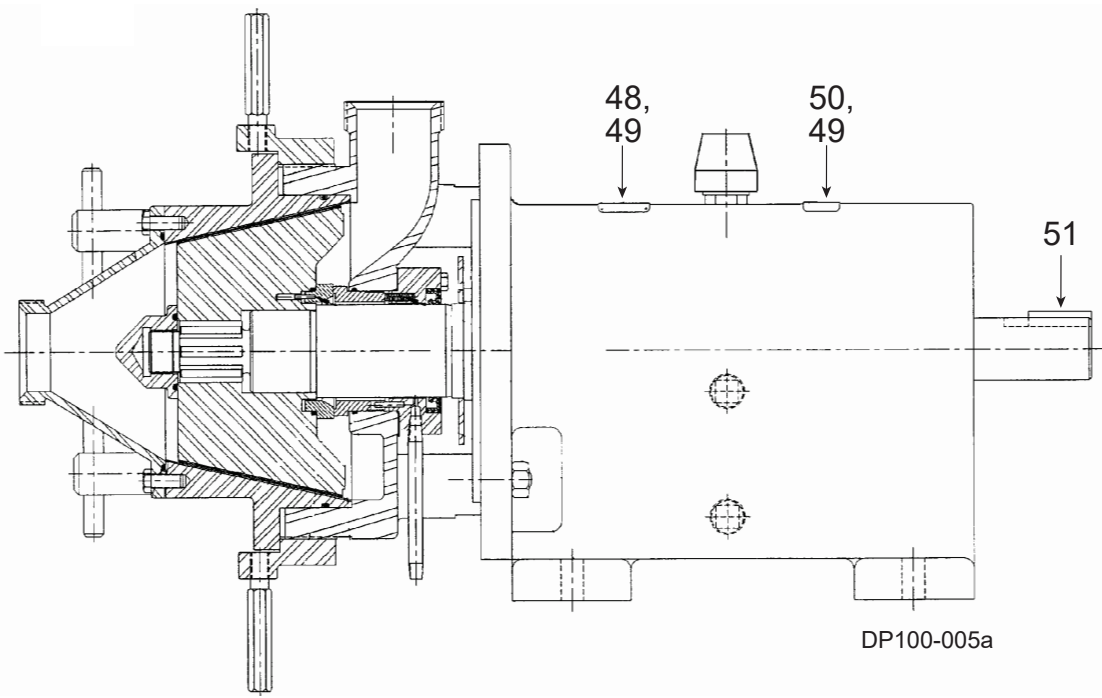
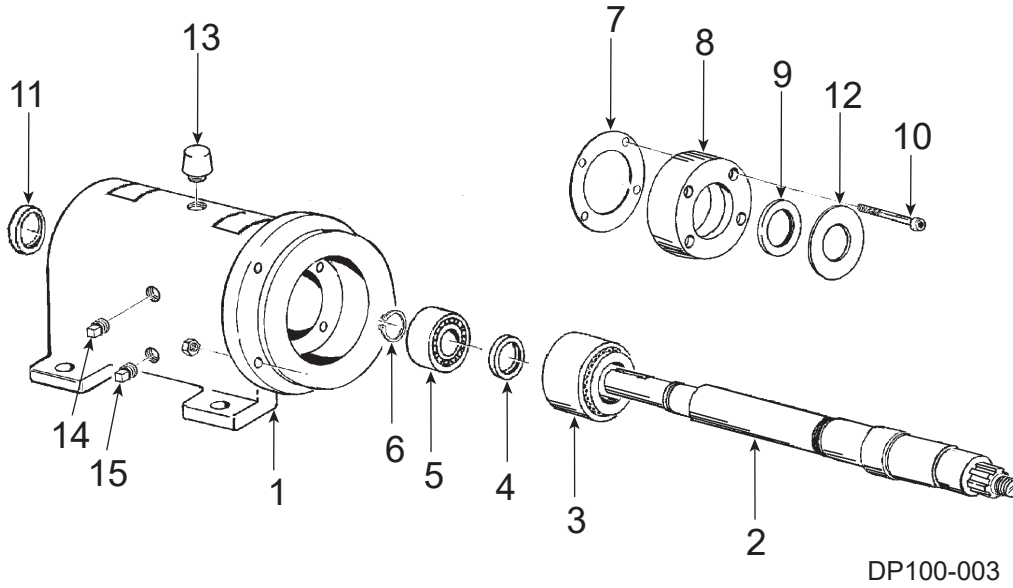

Colloid Mill Gear Case

ITEM NO.	DESCRIPTION	QTY	PART NO.	NOTES
1	Gear Case	1	OMS005000	
2	Drive Shaft	1	OMS008000	
3	Front Bearing	1	OMS036300	
4	Bearing Locknut	1	OMS036N00	
5	Rear Bearing	1	OMS036000	
6	Retaining Ring	1	BD0087R00	
7	Front Bearing Retainer Gasket	1	OMS042B00	
8	Front Bearing Retainer	1	OMS080000	
9	Pump End Shaft Seal	1	OMS030100	
10	Capscrew	4	30-274	
11	Drive End Shaft Seal	1	OMS030000	
12	Slinger	1	OMS045000	
13	Breather	1	139779+	
14	Level Indicator	1	115799+	
15	Drain Plug	1	115798+	
48	Nameplate, Sanitary	1	001061002	
49	RHDS	6	30-355	
50	Caution Label, Yellow	1	33-62	
51	Key	1	000037003	
52	Rotor Nut Wrench	1	CD0019001	

PL5081-CH12

Colloid Mill Fluid Head

NOTE:
Body rotor
clearance starts
at 0.101" and
ends at 0.220"
in increments of
0.010"

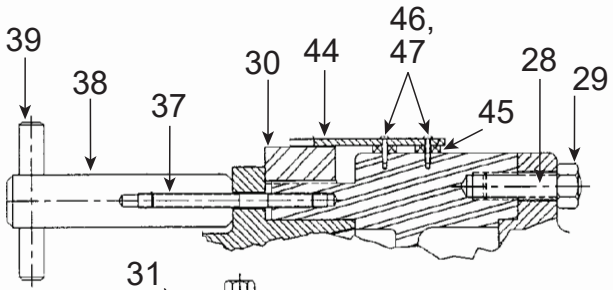

NOTE:
Torque rotor nuts
to 75 ft-lb

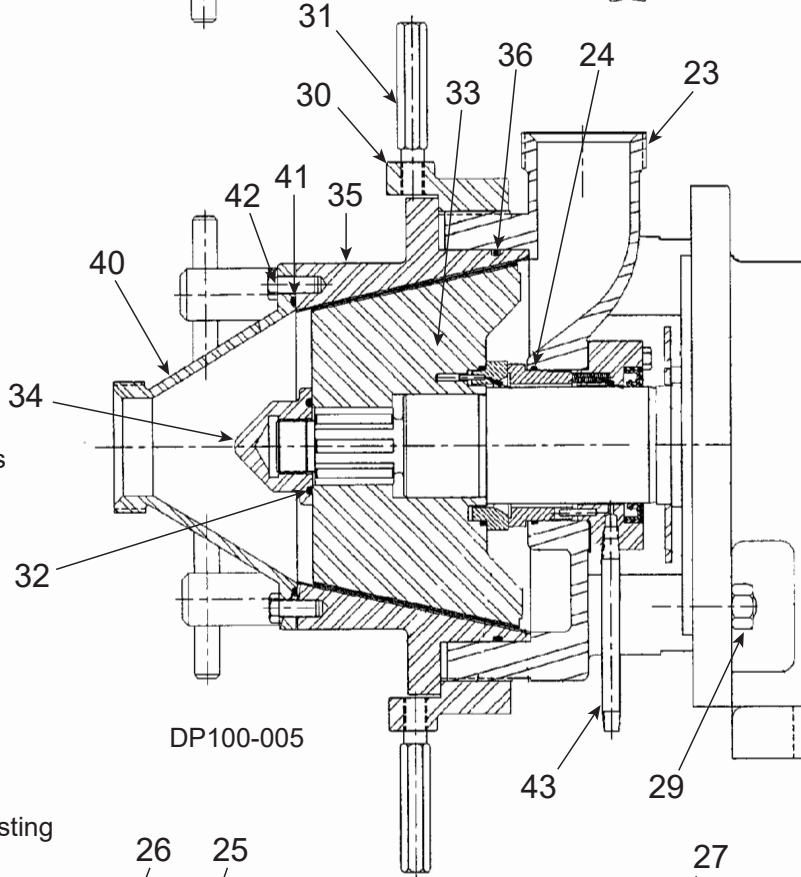

Used to set adjusting
ring at minimum
setting of 0.010"

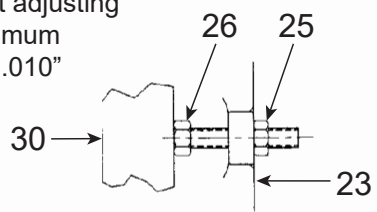

Used to hold
adjusting ring
setting

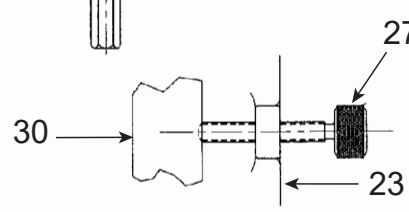

Colloid Mill Fluid Head

ITEM NO.	DESCRIPTION	QTY	PART NO.	NOTES
23	Body, 2" Bevel Seat	1	0MS001000	
	Body, 2" TCF	1	35886+	
24	Seal Seat & Body O-ring, FKM	2	V70150	
	Seal Seat & Body O-ring, Silicone	2	S75150	
25	Hex Nut	1	36-55	
26	Capscrew	1	30-86	
27	Knurled Lock Screw	1	0MS129000	
28	Stud - Body	4	0MS011000	
29	Hex Nut	4	36-70	
30	Adjusting Ring	1	0MS003000	
31	Adjusting Ring Handle	2	0MS054000	
32	O-ring, Rotor Nut, FKM	1	V70222	
	O-ring, Rotor Nut, Silicone	1	S75222	
33	Rotor	1	0MS010000	
34	Rotor Retaining Nut	1	0MS052000	
35	Stator	1	0MS004000	
36	O-ring, Stator, FKM	1	V70263	
	O-ring, Stator, Silicone	1	S75263	
37	Stud, Handle Shaft	4	0MS011100	
38	Handle Shaft	4	0MS099000	
39	Handle Pin	4	0MS100000	
40	Cover, 2" Bevel Seat	1	0MS002000	
	Cover, 2" TCF	1	35887+	
41	O-ring, Cover, FKM	1	V70253	
	O-ring, Cover, Silicone	1	S75253	
42	Capscrew	4	30-151	
43	Pipe Nipple	2	0MS018000	
44	Indicator	1	0MS056100	
45	Spacer	2	0MS454000	
46	Machine Screw	2	30-299	
47	Lockwasher, #10	2	43-21	

PL5081-CH13

Sanitary Seal

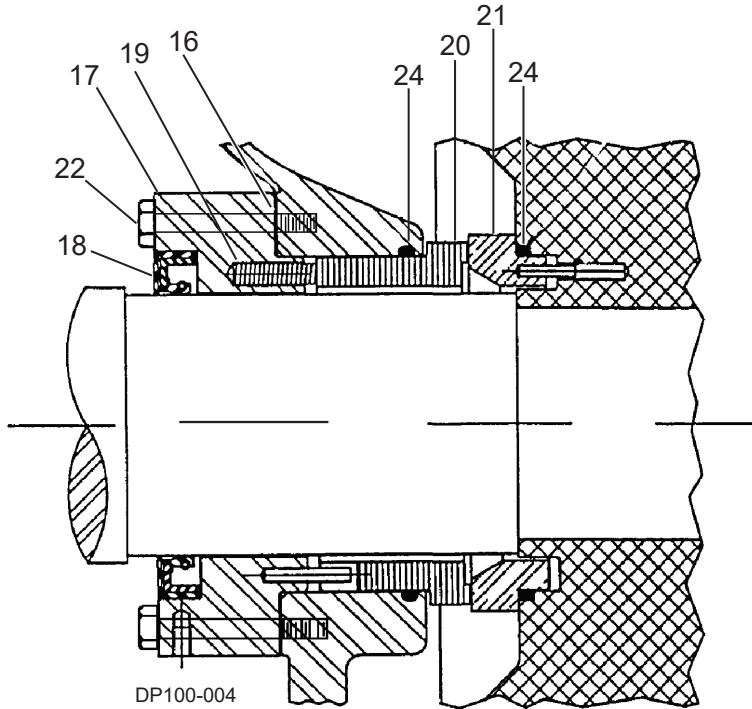

Item No.	Description	Qty	Part No.
16	Gland Gasket	1	0MS042G00
17	Gland Plate	1	0MS058200
18	Gland Plate Lip Seal	1	0MS030200
19	Spring	6	0MS304200
20	Stationary Seal, Carbon	1	0MS306003
	Stationary Seal, Silicon Graphite	1	0MS306004
	Stationary Seal, Silicon Carbide	1	0MS306009
21	Rotating Seat, Silicon Graphite	1	0MS014002
22	Capscrew	4	30-98
24	Seal Seat & Body O-ring, FKM	2	V70150
	Seal Seat & Body O-ring, Silicone	2	S75150

PL5081-CH11

KIT # 35379+ Convert single spring seal to multiple spring seal

Triplex Sales
1-847-839-8442
www.triplexsales.com



SPX FLOW, Inc.

611 Sugar Creek Road
Delavan, WI 53115

P: (262) 728-1900 or (800) 252-5200

F: (262) 728-4904 or (800) 252-5012

E: wcb@spxflow.com

SPX FLOW reserves the right to incorporate our latest design and material changes without notice or obligation.

Design features, materials of construction and dimensional data, as described in this bulletin, are provided for your information only and should not be relied upon unless confirmed in writing.

Please contact your local sales representative for product availability in your region. For more information visit www.spxflow.com.

The green ">" is a trademark of SPX FLOW, Inc.

ISSUED 09/2019

COPYRIGHT ©2019 SPX FLOW, Inc.