



**Waukesha  
Cherry-Burrell**



**TRIPLEX**  
Sales Company

Read and understand this manual prior to installing,  
operating or maintaining this pump.

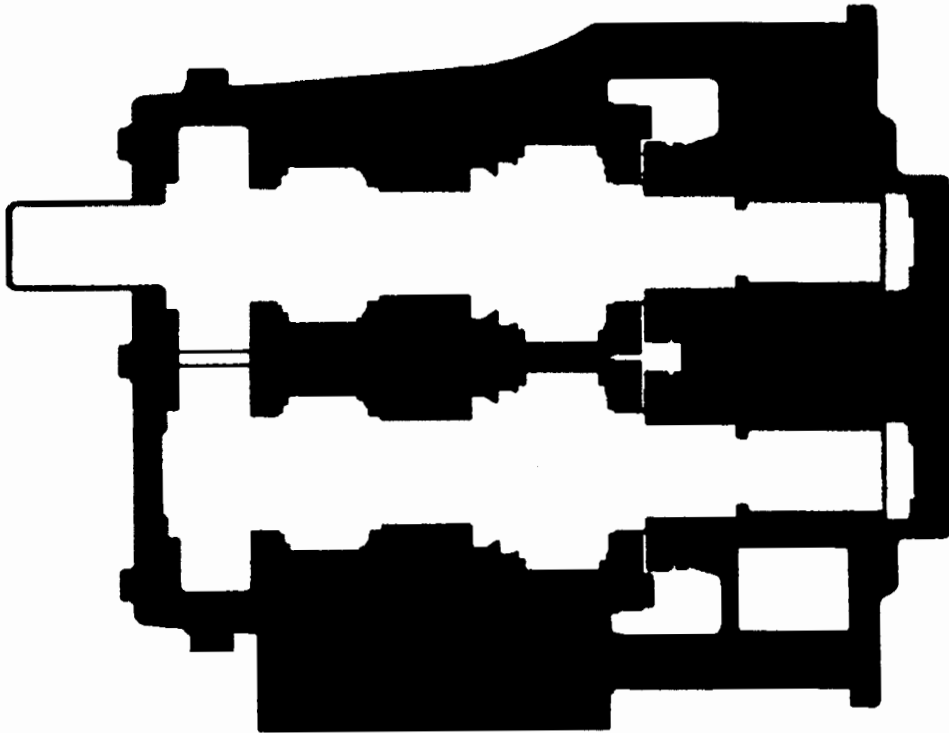

**Waukesha Pump  
SANITARY "DO" SERIES  
SERVICE ONLY**

**OPERATION  
MAINTENANCE  
& PARTS LIST**

## TABLE OF CONTENTS

Section		Page
I	Receiving and Warranty .....	2
II	Installation .....	5
III	Start-Up Check List .....	10
IV	Troubleshooting a Pumping System .....	11
V	Operation .....	15
	Fluid Head Disassembly – All Models .....	15
	Fluid Head Assembly – All Models .....	17
VI	Maintenance .....	19
	Visual Checks .....	19
	“Feel” Checks .....	20
	Seal Maintenance .....	21
	“O” Ring – DO Style Single and Double .....	21
	Annual Maintenance .....	22
VII	Factory Reconditioning .....	23
VIII	Disassembly Procedures .....	23
	Gear Cover and Gears – All Models .....	23
	Shaft Removal .....	24
	Model 2 .....	24
	Models 3, 10, 16, 25, 55, 100, 125 and 200 .....	25
IX	Assembly Procedures .....	27
	Model 2 .....	27
	Models 3, 10, 16, 25, 55, 100, 125 and 200 .....	28
	Gear and Gear Cover Assembly – All Models .....	31
	Back Face Clearance .....	32
X	Reference Tables and Repair Parts List .....	33
	Vented Cover .....	34
	Model 2-DO .....	37
	Model 3-DO .....	39
	Models 10-DO and 10-GT .....	41
	Model 16-DO .....	43
	Models 25-DO, 25-TO and 25-GT .....	45
	Models 55-DO, 55-TO and 55-GT .....	47
	Model 100-DO .....	49
	Models 125-DO, 125-TO and 125-GT .....	51
	Models 200-DO, 200-TO and 200-GT .....	53



## SECTION I RECEIVING AND WARRANTY

### **FACTORY INSPECTION**

Each "WAUKESHA" pump is shipped completely assembled, lubricated and ready for use. The "WAUKESHA" pump is a precision product, designed to provide long, trouble-free service in a properly designed system with normal maintenance.

### **RECEIVING INSPECTION**

Ports are covered at the factory to keep out foreign objects. If covers are missing or damaged, a thorough inspection of fluid head, by removing pump cover, is recommended. Be sure pumping head is clean and free of foreign material before rotating shaft.

### **LOSS OR DAMAGE**

If your pump has been lost or damaged in transit, file a claim at once with the delivering carrier. They have signed the Bill of Lading acknowledging that the shipment has been received from us in good condition. Our responsibility for the shipment has ceased.

We will of course assist you in every way in collecting claims for loss, or damage, however, we are not responsible for the collection of claims or replacement of material.

### **WARRANTY**

To insure full warranty coverage of your new pump, be sure to fill out the "Warranty Validation" form, shipped with your pump, to properly describe your pumping system. This will enable the factory to have a complete file on your pump and provide a ready reference for trouble shooting if problems develop.



**WARRANTY**

PROVIDED THE ITEMS COVERED ARE USED AS RECOMMENDED AND HAVE NOT BEEN SUBJECTED TO ACCIDENT, ALTERATION, ABUSE OR MIS-USE, SELLER WARRANTS EVERY PART MANUFACTURED BY IT TO BE FREE OF DEFECTS OF MATERIAL AND WORKMANSHIP AND UPON PREPAID RETURN OF DEFECTIVE MATERIALS OR COMPONENTS, WILL SHIP REPLACEMENT PARTS TO PURCHASER F.O.B. SHIPPING POINT. ALL PARTS OR COMPONENTS NOT MANUFACTURED BY SELLER ARE WARRANTED ONLY TO THE EXTENT OF THE WARRANTY OF THE RESPECTIVE MANUFACTURERS. ALL CLAIMS FOR CONSEQUENTIAL DAMAGES ARE EXPRESSLY WAIVED BY PURCHASER AND THIS WARRANTY IS IN LIEU OF ALL OTHER WARRANTIES EXPRESSED OR IMPLIED.



®

**Waukesha  
Cherry-Burrell**

611 Sugar Creek Rd. / Delavan, WI 53115  
414-728-4320 / Fax: 414-728-4320 / 1-800-274-9468

Cut Here

**WARRANTY VALIDATION**

(Please fill out in full and return to Waukesha)

Customer Name: J. D. Co. P.O. No. W-2506  
Address: 1610 1<sup>ST</sup> ST. Start Up Date: 11/4/75  
ANYTOWN, U.S.A.  
Distributor UNKNOWN Shipped Date: \_\_\_\_\_  
Pump Model 55 GT Serial No. 1846555 Speed 300  
Drive Type VAR. SPEED (55-150) H.P. 7.5

(See other side)



### INSTRUCTIONS FOR IN WARRANTY REPAIR

"If your "WAUKESHA" pump has been in use less than one year and becomes defective, it may be returned to Waukesha Pumps in accordance with the Warranty on reverse side.

In the event that the pump qualifies for "free repairs", it will be repaired and returned to you prepaid. If it does not qualify for "free repairs", you will be so advised, and the reason therefore given. You will also be informed of the cost involved in making the necessary repairs, and in such event, no work will be undertaken to repair the pump, until after you have requested that the necessary repairs be made and you will have approved the charges for the same".

This guarantee is based upon your date of purchase. Please fill in the following information now. *If service becomes necessary*, return this form with letter of transmittal.

Date of Purchase

Size of Pump

Name of Your Company

Serial Number

### WARRANTY VALIDATION

(Please fill in as much as possible)

Fluid Name/Type Corn Syrup

Viscosity 2000 CPS \_\_\_\_\_ SSU

Temp. 110 °F S.G. 1.25 V.P. ?

Solids ? % Particle Size \_\_\_\_\_

DISSOLVED

Particle Description \_\_\_\_\_

Abrasive

Nonabrasive

Inlet 9 NIPA Outlet 80 PSI

Schematic:

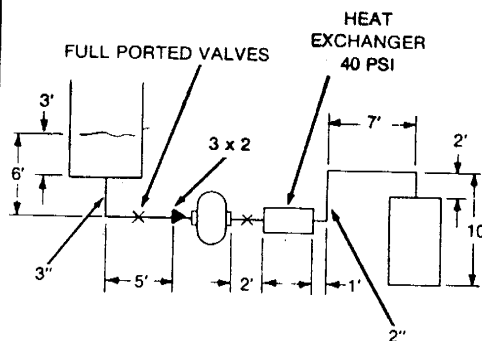

## SECTION II INSTALLATION

The installation of your Waukesha pump and its piping system should follow good practice to give optimum performance, and be in accordance with local codes and restrictions.

All system equipment, such as motors, sheaves, drive couplings, speed reducers, etc., must be properly sized to insure satisfactory operation of your Waukesha pump within its limits.

**CAUTION:** Waukesha pumps are positive displacement, low slip design and will be severely damaged if operated with closed valves in discharge or inlet lines. Pump warranty is not valid for damages caused by a hydraulic overload from operation or start-up with a closed valve in the system.

### PUMP INSTALLATION

The installation of your Waukesha pump and its piping system should follow good practice to give optimum performance.

#### 1. Installing the Pump and Drive Unit.

Pumps of this type and size are generally mounted on a common base plate with the drive.

The unit can be installed in the plant location in several ways:

Permanent installation on foundation with bolts and grout.

Level unit before grouting.

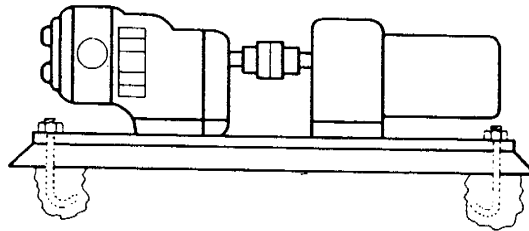

Leveling and/or vibration isolation pads.

Many commercial types available.

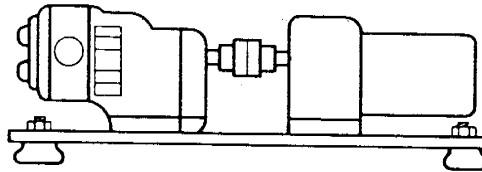



Adjustable leg base, commonly used for sanitary pumps. For washdown under base. Can be easily moved or repositioned.

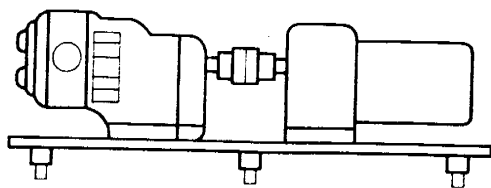

Portable bases—for movement to different locations.

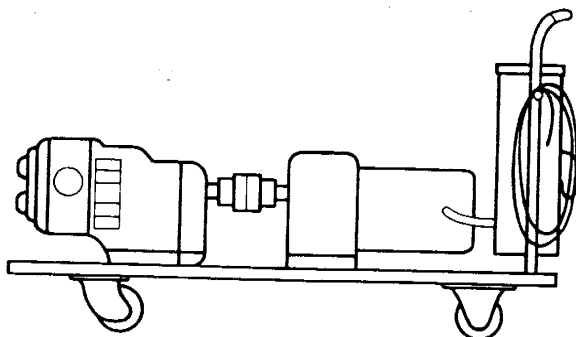

## 2. Good Piping Practice,

All piping to the pump should be supported independently, to minimize the forces exerted on the pump. Such forces can cause misalignment of pump parts and lead to excessive wear of rotors, bearings and shafts.

Piping support:  
Weight of piping and fluid—support piping independently with hangers or pedestals.

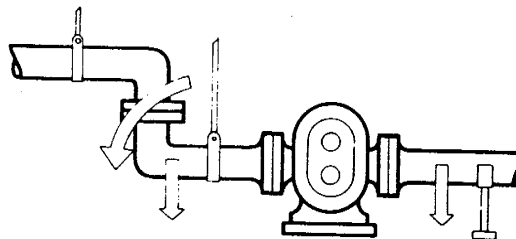

Thermal expansion of piping—can cause tremendous forces. Use thermal expansion joints to minimize forces on pump.

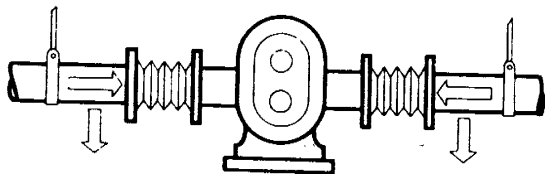

Flexible joints can also be used to limit the transmission of mechanical vibration. Anchor free ends of any flexible hose in system.



### Piping Layout

Inlet side—slope piping up to inlet to avoid air pocket.

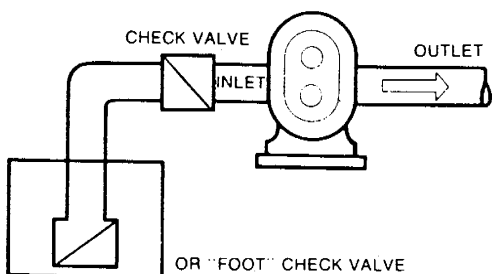
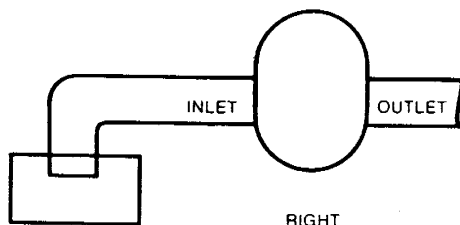
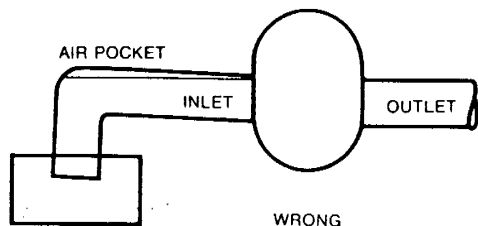

Inlet side—use check valves to keep inlet line full, particularly with low viscosity fluids, and in start-stop operation.

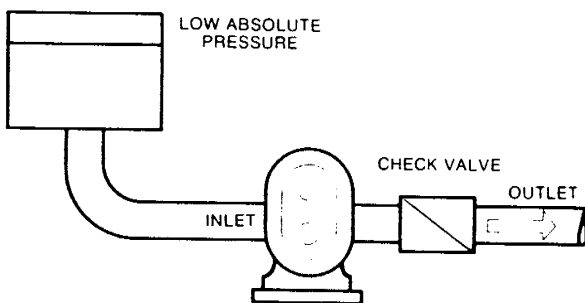

Inlet "Vacuum" Service—use check valve on outlet side

- Prevents backflow (air or fluid)
- Facilitates initial start-up (minimizes differential pressure pump must supply to start flow)

"Isolation" Valves—permit pump maintenance and removal safely and without emptying entire system

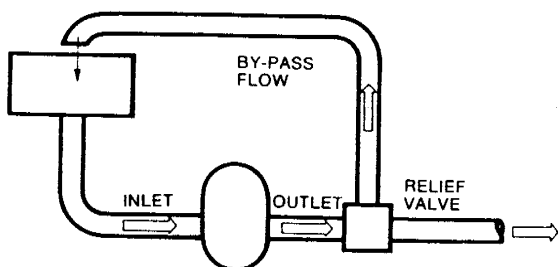
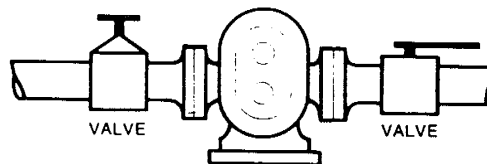

### Relief Valve

To protect the pump and piping system against excessive pressure, a relief valve should be installed. An integral relief valve, designed to bypass the fluid internally from the pump outlet to the inlet, should not be used on applications where the discharge must be closed for more than a few minutes. Prolonged operation of the pump with closed discharge will cause heating of the fluid circulating through the relief valve. When such operation is necessary, the relief valve, whether integral, attachable, or line-mounted, should discharge externally through piping connected to the fluid source, or if that is not practical, into the inlet piping near the source.





A particular relief valve design will have a characteristic curve such as shown. The "cracking pressure" can usually be set by spring adjustment, or by adjustable pneumatic pressure, etc. Flow will begin to bypass when this "cracking pressure" is reached. As flow increases through the bypass, the system pressure will also increase.

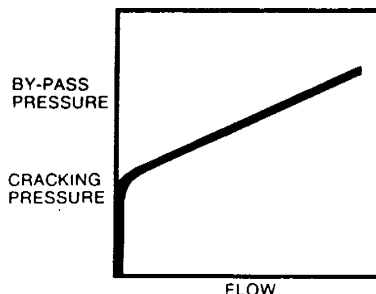

The pressure increase for a given valve design depends on the valve setting, the flow rate, and the viscosity of the fluid being pumped. If the full-flow bypass pressure exceeds the maximum allowable for the particular pump and piping system, an oversize attachable relief valve may sometimes be used to limit the full-flow bypass pressure to an acceptable value.

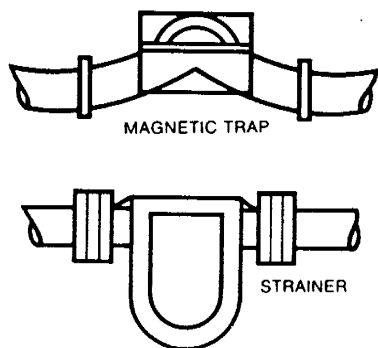

**Inlet Side—Strainers and Traps.**

Inlet side strainers and traps can be used to prevent pump damage from foreign matter. Selection must be **carefully made** as clogging can easily occur, restricting the inlet, causing cavitation and flow stoppage.

**Pressure Gauges**

Pressure and "Vacuum" gauges provide the easiest way to tell you something about the pump operation.

- Normal or abnormal pressures
- Overload conditions
- Indication of flow
- Changes in pump condition
- Changes in system conditions
- Changes in fluid viscosity

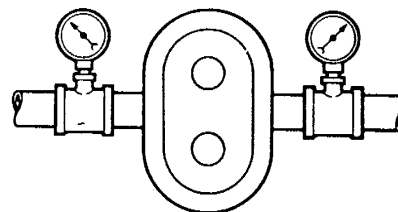

**Wherever possible—install gauges!!**

**3. Alignment of Pump to Drive.**

Pumps and drives which are ordered from the factory and mounted on a common base plate are accurately aligned before shipment. The alignment should be re-checked after the complete unit has been installed and the piping completed. Periodic re-checking is advisable during the pump service life.



In-line Drives. For initial pump installation, and for re-checking alignment, it is advised.

A flexible coupling should be used to connect the drive to the pump. Many different types are available, including couplings with slip or overload provision.

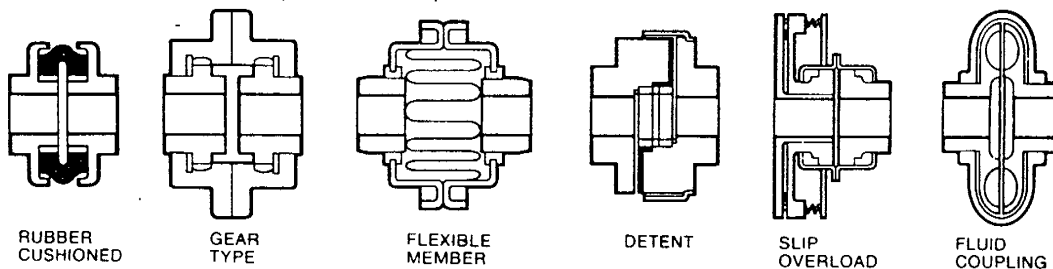

A flexible coupling is used to compensate for end play and **small** differences in alignment. The pump and drive shaft should be aligned as closely as is possible.

Checking angular alignment:  
Using feeler gauges, or taper gauges.

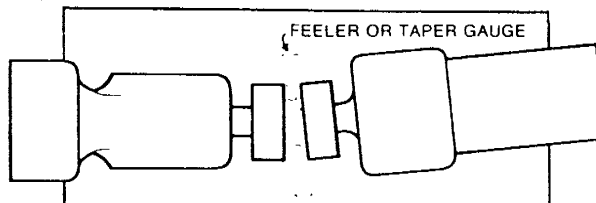

Adjust to get equal dimension at all points—at the same time set space between coupling halves to manufacturer's recommended distance.

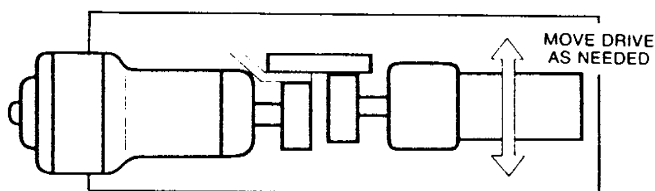
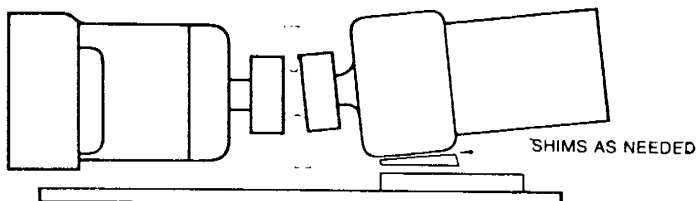

CHECK AT 4 POINTS AROUND COUPLING—EVERY 90°

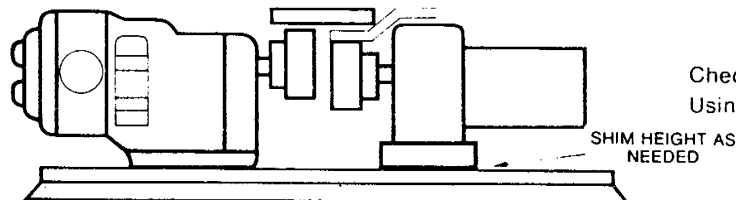

Checking Parallel Misalignment:  
Using straight edges and shims:

After piping is complete, and drive and couplings are aligned, **turn pump shaft manually** to see that it turns freely without binding.

**Check rotation direction** of drive to see that pump will rotate in proper direction. Facing "Liquid End" of pump:

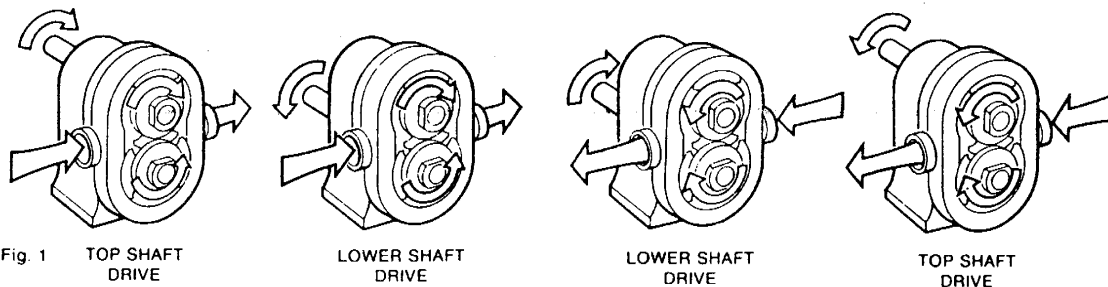

**THEN CONNECT COUPLING HALVES**

Aligning belt and chain drives.  
Using straight-edges and visual check:

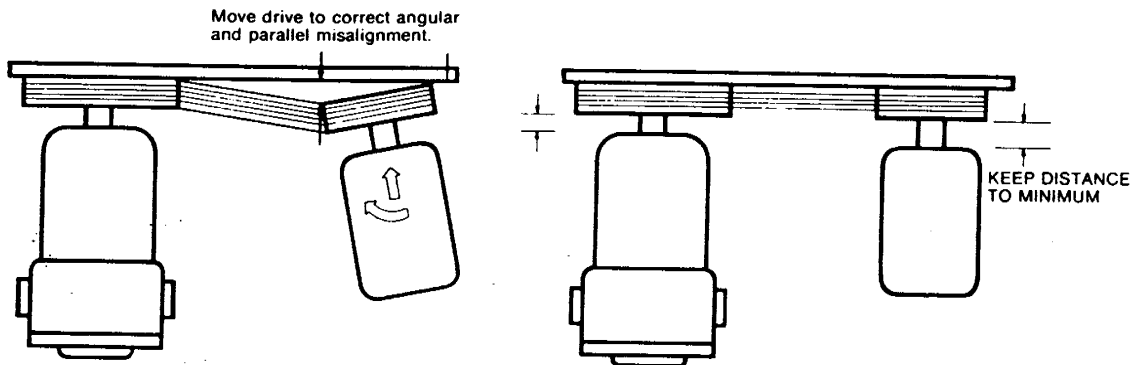

After piping is complete and before belts are installed, **turn pump shaft manually** to see that it turns freely.

Check rotation direction of pump to see that pump will rotate in proper direction (see figure 1 ).  
Then install belts and tension them correctly.

### SECTION III START-UP CHECK LIST

The Waukesha Pump is a positive displacement pump and thus can develop very high pressures. To protect lines, equipment and personnel, certain precautions must be taken.

1. Review Section II, particularly "Relief Valves." Install relief valves if needed in system.
2. Check that piping and pump are clean and free of foreign material, such as welding slag, gaskets, etc. **Do not use pump to flush system.**
3. See that all piping connections are tight and leak-free. Where possible, check system with "non-hazardous" fluid.
4. Check to see that pump and drive are lubricated. See Section V. Install breather screw. Check Drive Lubrication Instruction.
5. Check that all guards are in place and secure.
6. Seals: Packing — supply flushing fluid if needed. Leave packing gland loose for normal 'weepage'! Make adjustments as initial conditions stabilize, to maintain normal weepage. Mechanical seals with flushing — supply adequate flow of clean flushing fluids.
7. See that all valves are open on discharge system, and that free flow path is open to destination.
8. See that all valves are open on inlet side, and that fluid can reach pump.
9. Check direction of pump and drive rotation (jogging is recommended).
10. Start pump drive. Where possible, start at slow speed, or jog.

Check to see that liquid is reaching pump within several minutes. If pumping does not begin and stabilize, check items under "No Flow" or "Insufficient Flow" in Section IV, Troubleshooting a Pumping System.

## SECTION IV

# TROUBLESHOOTING A PUMPING SYSTEM

### TROUBLESHOOTING A PUMPING SYSTEM

Once a pump is properly selected and installed in a system, operation should be troublefree. However, in existing systems, or as pump and system conditions change, problems may develop. Following are some troubleshooting hints to help identify and solve problems.

<b>Problem</b>	<b>Probable Causes</b>	<b>Solutions</b>
No flow, pump not turning	Drive motor not running	Check resets, fuses, circuit breakers
	Keys sheared or missing	Replace
	Drive belts, power transmission components slipping or broken	Replace or adjust
	Pump shaft, keys, or gears sheared	Inspect; replace parts
No flow, pump turning	Wrong direction of rotation	Reverse
No flow, pump not priming	Valve closed in inlet line	Open valve
	Inlet line clogged or restricted	Clear line, clean filters, etc.
	Air leaks due to bad seals or pipe connections	Replace seals; check lines for leakage (can be done by air pressure, or by filling with liquid and pressurizing with air)
	Pump speed too slow	Increase speed. Filling inlet lines with fluid may allow initial start-up. Foot valve may solve start-up problems permanently.
	Liquid drains or siphons from system during off periods	Use foot valve or check valves



<b>Problem</b>	<b>Probable Causes</b>	<b>Solutions</b>
No flow, pump not priming	"Air" lock. Fluids which "gas off," or vaporize, or allow gas to come out of solution during off periods	Manual or automatic air bleed from pump or lines near pump
	Extra clearance rotors, worn pump	Increase pump speed, use foot valve to improve priming
	Net inlet pressure available too low	Check NIPA, NIPR*, recalculate system. Change inlet system as needed.
No flow	On "Vacuum" inlet system: On initial start-up, atmospheric "blow back" prevents pump from developing enough differential pressure to start flow.	Install check valve in discharge line
	Relief valve not properly adjusted, or held off seat by foreign material (flow is being recirculated to inlet)	Adjust or clear valve
Insufficient flow	Speed too low to obtain desired flow	Check flow-speed curve
	Air leak due to bad seals or pipe connections	Replace seals, check inlet fittings.
Fluid vaporization ("starved" pump inlet)	Strainers, foot valves, inlet fittings or lines clogged	Clear lines. If problem continues, inlet system may require change
	Inlet line size too small, inlet line length too long. Too many fittings or valves. Foot valves, strainers too small.	Increase inlet line size. Reduce length, minimize direction and size changes, reduce number of fittings.
	NIPA too low	Raise liquid level in source tank
	NIPA too low	Increase by raising or pressurizing source tank

\*NIPA - Net Inlet Pressure Available at Pump  
NIPR - Net Inlet Pressure Required by Pump



<b>Problem</b>	<b>Probable Causes</b>	<b>Solutions</b>
Fluid vaporization ("starved" pump inlet)	NIPA too Low	Select larger pump size with smaller NIPR
	Fluid viscosity greater than expected	Reduce pump speed and accept lower flow, or change system to reduce line losses.
	Fluid temperature higher than expected (vapor pressure higher)	Reduce temperature, reduce speed and accept lower flow or change system to increase NIPA
Insufficient flow, fluid being bypassed somewhere	Relief valve not adjusted or jammed	Adjust or clear
	Flow diverted in branch line, open valve, etc.	Check system and controls
Insufficient flow, high slip	Hot (HC) or extra clearance rotors on "cold" fluid, and/or low viscosity fluid	Replace with standard clearance rotors
	Worn pump	Increase pump speed (within limits). Replace rotors, recondition pump.
	High pressure	Reduce pressure by system changes
Noisy operation	<b>• Cavitation</b>	
	High fluid viscosity, High vapor pressure fluids, High temperature	Slow down pump, reduce temperature, change system
	NIPA less than NIPR	To increase NIPA or reduce NIPR, see Engineering Manual
	<b>• Air or gas in fluid</b>	
	Leaks in pump or piping	Correct leaks
Dissolved gas or naturally aerated products	Minimize discharge pressure. Also see "Cavitation" above.	
	<b>• Mechanical noises</b>	
	<b>Rotor to body contact</b>	
	Improper assembly	Check clearance with shims. See pages 46 and 47.



<b>Problem</b>	<b>Probable Causes</b>	<b>Solutions</b>	
Noisy operation	<b>• Rotor to body contact</b> Distortion of pump due to improper piping installation	Reassemble pump or re-install piping to assure free running	
	Pressure higher than rated	Reduce pressure if possible	
	Worn bearing	Rebuild with new bearings, lubricate regularly	
	Worn gears	Rebuild with new gears, lubricate regularly	
	<b>• Rotor to rotor contact</b> Loose or mis-timed gears, twisted shaft, sheared keys, worn splines	Rebuild with new parts	
	<b>• Relief valve chattering</b>	Re-adjust, repair or replace	
	<b>• Drive component noise—gear trains, chains, couplings, bearings.</b>	Repair or replace drive train	
	Pump requires excessive power (overheats, stalls, high current draw, breakers trip)	<b>• Higher viscous losses than expected</b>	If within pump rating, increase drive size
		<b>• Higher pressure than expected</b>	Reduce pump speed, increase line sizes
		<b>• Fluid characteristics</b> Fluid colder than expected, viscosity high	Heat fluid, insulate or heat trace lines. Use pump with more running clearances.
Fluid sets up in line and pump during shut down		Insulate or heat trace line. Install "soft start" drive. Install recirculating bypass system. Flush with other fluid.	
Fluid builds up on pump surfaces (example, latex, chocolate, fondants)		Use pump with more running clearance	
"Short" pump service life	High corrosion rate	Upgrade material of pump	
	Pumping abrasives	Larger pumps at slower speeds, can help	
	Speeds and pressures higher than rated	Reduce speeds and pressures by changes in system	
	Worn bearings and gears due to lack of lubrication	Set up and follow regular lubrication schedule	
	Misalignment of drive and piping. Excessive overhung load or misaligned couplings.	Check alignment of piping. Check drive alignment and loads.	



## SECTION V OPERATION

### NORMAL OPERATION

Normal operation covers a speed range of 0-600 RPM and pressure range of 0-150 PSI for all models except the new universal series which are rated at 0-200 PSI. Temperature range with standard rotors is -40 to 180° F and with hot clearance rotors, 180 to 300° F. (For operation at higher temperatures, consult factory.)

**NOTE:** All hot clearance rotors are identified with a stamped letter "H" on rotor hub.

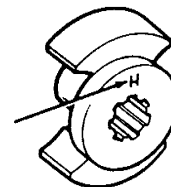

### LUBRICATION

The gears are factory lubricated with Micro-Plate No. 140 oil.

The bearings are factory greased with Micro-Plate #2 grease.

Change oil every 500 hours. If pump is installed where moisture and condensation are heavy, change oil more frequently.

Bearings must be greased every 250 hours or less depending on moisture and condensation conditions. Excess grease will accumulate in the bearing housing and can be removed through the cleanout hole covered with plastic plug.

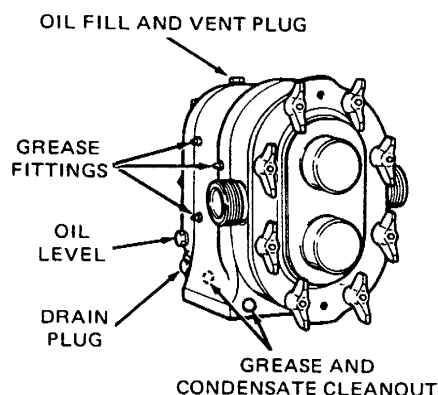

**NOTE:** For hot or cold extremes use appropriate lubricant as shown in the following table.

OIL	GREASE
Micro-Plate #140 (-10 to 450° F)	Silicone (-20 to +5° F) Micro-Plate #2 (+5 to +400° F)

### DRIVE LUBRICATION

Refer to drive manufacturer's manual shipped with unit.

### CLEANING AND STERILIZING

The "Waukesha" pump is designed to be completely disassembled for thorough and easy cleaning. Clean the pump every day or at the end of a process. Disassemble the fluid head as outlined below. Remove and clean the "O" rings, sleeves and pump cover gaskets. Cleaning the pump "in-place" is not recommended.

### FLUID HEAD DISASSEMBLY - ALL MODELS

1. Shut off power and isolation valves and disconnect inlet and discharge lines.
2. Remove wing nuts using soft hammer to loosen them.

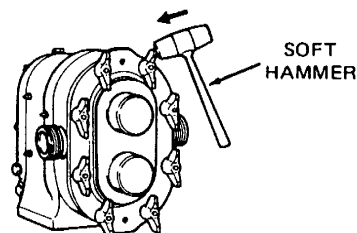



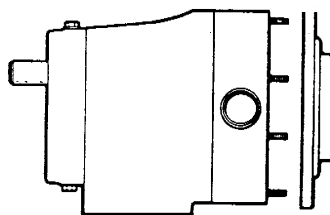

3. Remove cover. If it is stuck, loosen it with a soft hammer. Remove and discard cover "O" ring.

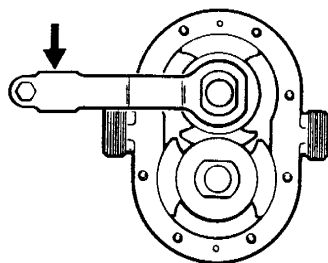
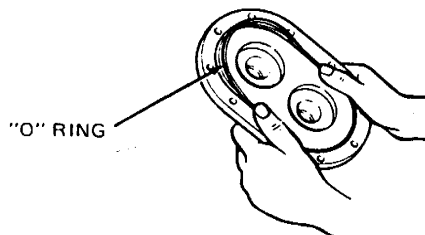

4. Remove rotor retaining nuts. Use the special wrench supplied with pump and hit it sharply with a soft hammer to loosen nuts.

5. Orient rotors perpendicular to each other and remove rotor with both wings exposed first. Handle rotors with care to avoid knicks and scratches. If it is stuck tight, use a gear puller or hardwood lever behind rotor hub to force it off spline.

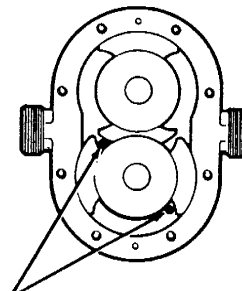

APPLY GEAR PULLER HERE

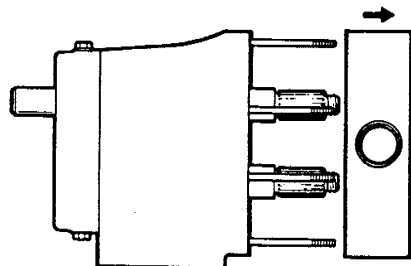

6. Remove pump body by pulling it straight off studs. Use a soft hammer to assist if body is stuck tight.

7. See Section VI for seal disassembly procedure.

8. Clean and inspect body thoroughly.

**CAUTION:** Body must be reassembled on bearing housing from which it was removed. Both are identified with same serial number.



## FLUID HEAD ASSEMBLY - ALL MODELS

### Seal Assembly

See SEAL MAINTENANCE, page 21 for assembly procedure on all models.

### Body Assembly

1. Slide body over shafts and studs being careful seal components are not knicked or knocked out of place. Press body firmly against housing engaging dowels.

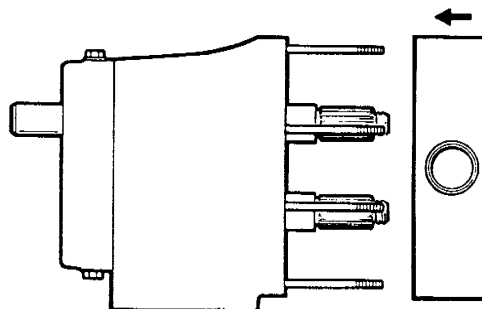

### Rotor Assembly

Assemble a rotor onto shaft engaging the large spline tooth with the large groove in rotor. Rotate shaft until rotor wings are on vertical centerline. Install the second rotor and secure both with rotor retaining nuts. Lock the nuts by hitting wrench sharply with a soft hammer.

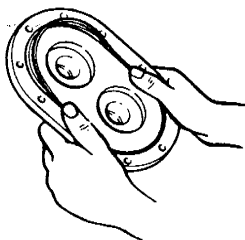
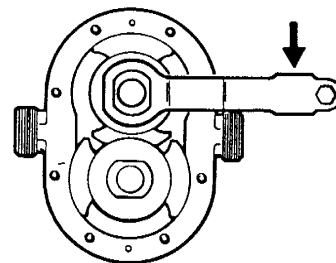

### Cover Assembly

1. Install "O" ring in cover groove.



2. Mount cover on studs and push it against body being sure "O" ring remains in the groove.
3. Attach wing nuts and tighten by hitting them sharply with a soft hammer.

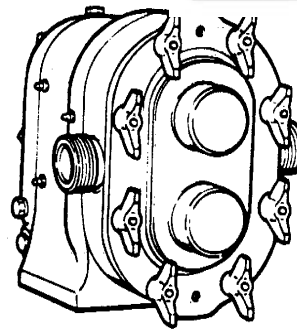

### Flushing Connection

**NOTE:** Flushing media should be piped into lower connection of each shaft seal and discharged from upper connection. Both inlets and outlets may be manifolded to simplify piping.

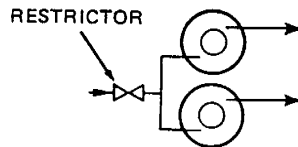
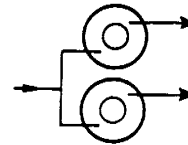

#### 1. Low Pressure Flush

- a. Set flow rate of approximately 1/4 GPM for most applications. For high temperature applications increase flow.
- b. Flushing media is restricted on inlet side and has free flow to drain on outlet side.

#### 2. High Pressure Flush

Flushing media is restricted on discharge side of pump flushing glands.

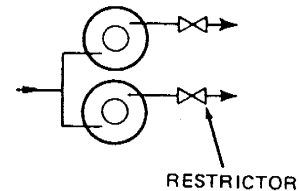



## SECTION VI MAINTENANCE

### GENERAL

In the maintenance of pumps it is important to recognize when parts are wearing excessively. Detecting wear in the early stages will let you repair your pump at minimum cost and get it back into operation at the earliest date.

Periodic cleaning and a simple "look-feel" inspection of your pump are recommended as good operating procedures and as a means of detecting signs of trouble at an early stage. They require only a few minutes and may save you an appreciable amount of money.

A more detailed maintenance inspection should be scheduled annually. See ANNUAL MAINTENANCE, Page 20.

The following routine "look-feel" checks are to be made by the system operator during shut-down periods.

### VISUAL CHECKS

1. Rotor wing tips for indications of metal-to-metal contact between rotor wings.

If this condition exists, the pump should be repaired or replaced.

CLEARANCE ON BOTH SIDES  
MUST BE EQUAL

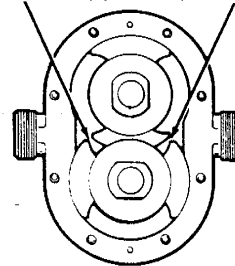

### VISUAL CHECKS

1. Rotor wing tips for indications of metal-to-metal contact between rotor wings.

If this condition exists, the pump should be repaired or replaced.

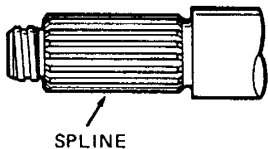

#### Cause

#### Corrective Measure

Worn shaft spline ..... Replace shaft.

Worn rotor spline ..... Replace rotor.

**NOTE:** Usually both parts will wear. The usual cause is a rotor which has been loose for extended running periods.

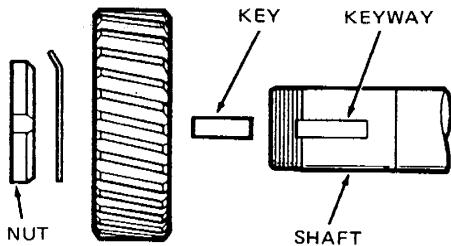
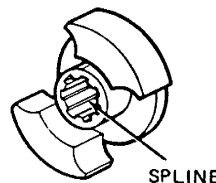

Loose gears ..... Remove gear and inspect key, keyway and shaft. If all are in good condition, reassemble and retighten gear retainer nuts to specified torque. (See Table 2.)

Worn gears ..... Replace gears.

Twisted shaft ..... Replace shaft.



2. Rotor hub end which locks against the shaft shoulder for signs of wear.

<b>Cause</b>	<b>Corrective Measure</b>
Extended running with loose rotor retaining bolts .....	Replace rotor or reshim shaft to maintain back face clearance. (See Table 1 and Section IX.)

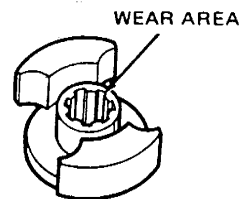

3. Shaft shoulder against which rotor hub locates and locks for deterioration.

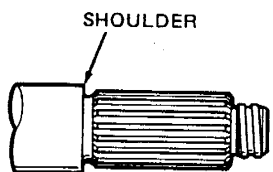

<b>Cause</b>	<b>Corrective Measure</b>
"Steps" worn into locating face by loose rotor .....	Reshim or replace shaft to maintain correct running clearances. (See Table 1.)

**"FEEL" CHECKS**

1. Gear Back Lash — If there is any free movement when rotating either shaft without transmitting motion to other shaft, the back lash is excessive.

<b>Cause</b>	<b>Corrective Measure</b>
Worn gear teeth .....	Replace gear.
Gear loose on shaft .....	Remove gear and inspect key, keyway and shaft. If all are in good condition, re-assemble and retighten gear retaining nuts to specified torque. (See Table 2.)

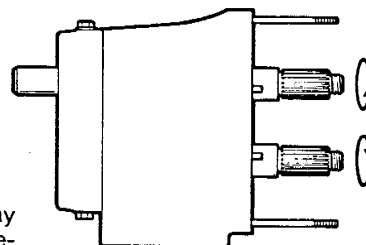

2. Bearing Condition — If movement of either shaft can be detected when hand loading the rotor end of the shaft (approximately 30 lbs. force applied as illustrated), bearing may be failing.

<b>Cause</b>	<b>Corrective Measure</b>
Lack of lubricant or high overload .....	Replace bearings and review lubrication schedule. Check for means to reduce hydraulic loads.

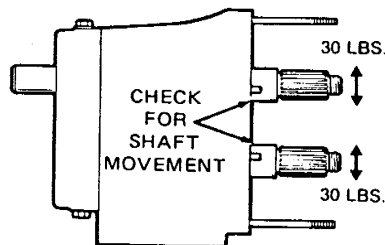

## SEAL MAINTENANCE

**NOTE:** To service seals it is necessary to disassemble fluid head. See FLUID HEAD DISASSEMBLY - ALL MODELS in Section V for procedure.

### 1. "O" Ring - D'O Style Single and Double.

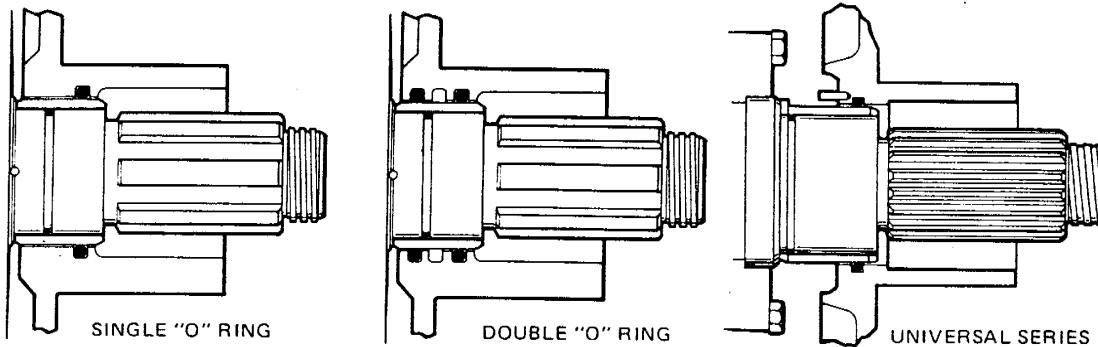

#### Service

- a. Remove and discard body "O" rings.

**NOTE:** Use "O" ring removal tool furnished with pump.

- b. Remove shaft sleeves and shaft "O" rings.
- c. Thoroughly clean and inspect grooves, shafts and sleeves. DO NOT re-use sleeves that are grooved or scratched.

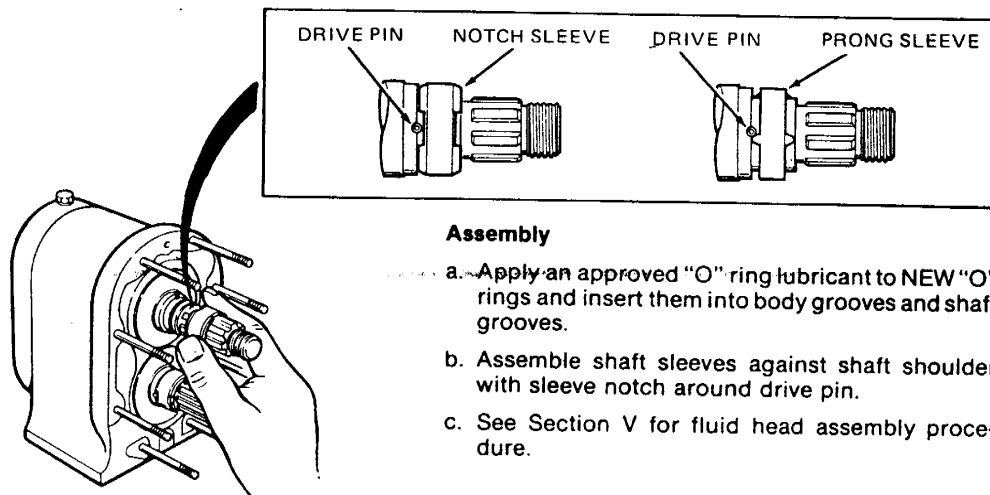
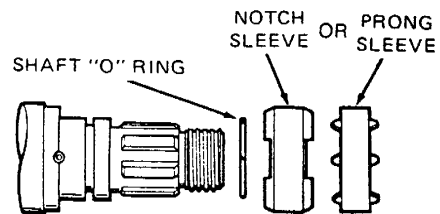

#### Assembly

- a. Apply an approved "O" ring lubricant to NEW "O" rings and insert them into body grooves and shaft grooves.
- b. Assemble shaft sleeves against shaft shoulder with sleeve notch around drive pin.
- c. See Section V for fluid head assembly procedure.

## ANNUAL MAINTENANCE

The same general procedures and corrective measures outlined above should be followed and in addition the following preventive maintenance operations should be carried out at this annual check out period.

1. Check bearing with a dial indicator for shaft radial play. If deflection is equal to or greater than rotor to body diametrical clearance (see Table 1), replace bearings.

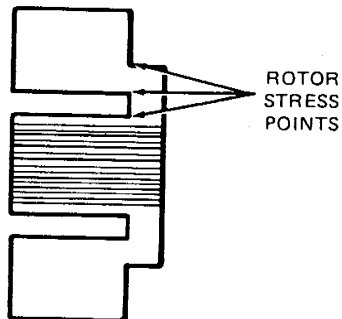
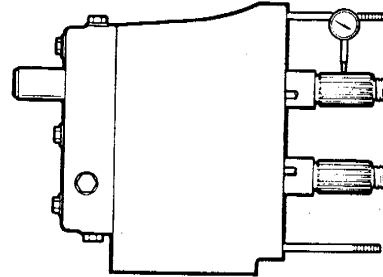

2. Remove gear cover and inspect gears for wear, back lash and looseness. Retorque gear retaining nuts to proper torque. (See Table 2)

3. Thoroughly inspect rotors for worn splines, bearing shoulder wear, and stress cracks. Use dye check method to detect any fatigue type cracks that may develop into serious trouble.

4. Review performance record on pump and check radial and back face clearances to determine wear and its effect on desired performance. (See Table 1 and Section IX.) An adjustment on operating speed can compensate for wear in some applications. When wear and subsequent performance is objectionable, we suggest you take advantage of our reconditioning program. (See Section VII.)

**NOTE:** If bearings or shafts are replaced "in the field" extreme care should be exercised to position the shaft, by shimming, to maintain sufficient running clearances between the rotor wing faces and the pump body faces (back face and cover face). See Table 1 and BACKFACE CLEARANCE, Section IX. If rotors are slightly out of time, they can be retimed by shimming the gears.

It is important to hold the same back face dimension for both rotors to avoid crossover interference.

## SECTION VII FACTORY RECONDITIONING

Waukesha pumps are designed so that they may be factory reconditioned twice and backed with a new pump warranty each time.

Factory reconditioning involves replacement of all worn parts such as shafts, bearings, oil seals, gears, etc. The pump body and cover are re-machined and new rotors are installed. The pumps are stamped R-1 or R-2, after the serial number, designating that they have been reconditioned once or twice.

**NOTE:** It is advisable to contact factory and furnish the serial number of any pump being considered for reconditioning.

When pumps require reconditioning it is recommended that they be returned to Waukesha Pumps with proper purchase order. Where this is not practical a "reconditioned" pump may be ordered in advance of the actual return of the pump being replaced.

While a large stock of reconditioned pumps is maintained, normal delivery of four weeks should be anticipated. In these cases an invoice will be issued for the price of a new pump with credit allowed upon receipt of the old pump at the factory so that net cost will be that of a reconditioned pump.

### INTERCHANGEABILITY

All new pumps of a given model are identified by a serial number on bearing housing nameplate and stamped on top of pump body. The housing and body must be kept together as a unit because of back face clearance. The rotors, seals and covers can be interchanged between units.

**ALL** reconditioned pump parts must be kept together as a unit. These are specially machined and are not interchangeable.

**NOTE:** If new body is replaced in the field, it is most important to check back face and front face clearances. (See Table 1.) Reshim shafts if required to avoid rotor and cover contact. Both rotors must have the same clearance to avoid crossover interference.

## SECTION VIII DISASSEMBLY PROCEDURES

### FLUID HEAD - ALL MODELS

Follow the instructions under FLUID HEAD DISASSEMBLY - ALL MODELS in Section V.

### SEALS - ALL MODELS

Follow the instructions under SEAL MAINTENANCE in Section VI.

### GEAR COVER AND GEARS - ALL MODELS

1. Remove oil drain plug and drain oil.
2. Remove cap screws from gear cover.
3. Pull gear cover off shaft extension. If cover sticks, use soft hammer to loosen it.
4. Remove and discard gear cover gasket.
5. Remove oil seal from cover with an arbor press and discard.

**NOTE:** Model 2-BB (DO) has a bearing in the cover behind oil seal; press it and oil seal out at the same time.

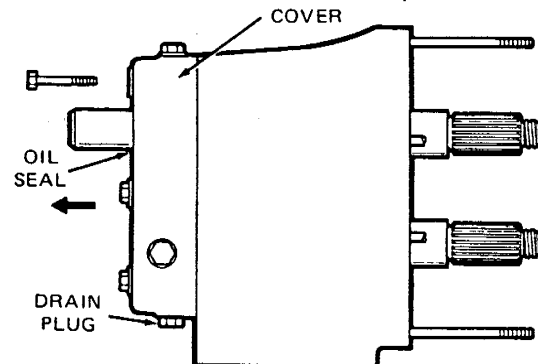





6. Straighten locking tab of lockwashers. Use spanner wrench or drift to remove gear lock nuts.

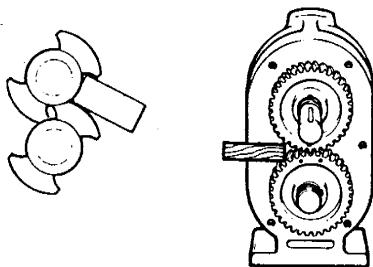
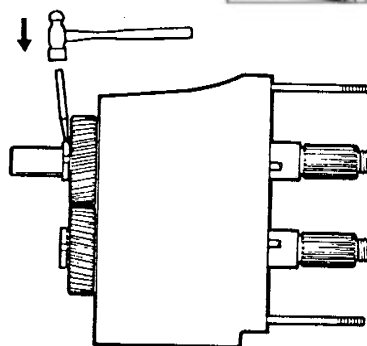

7. Prevent shafts from turning by wedging a wooden block between the gears or by installing the rotors and wedging a wooden block between them.

8. Use gear puller or hardwood wedges to remove gears. File any burrs that may develop.

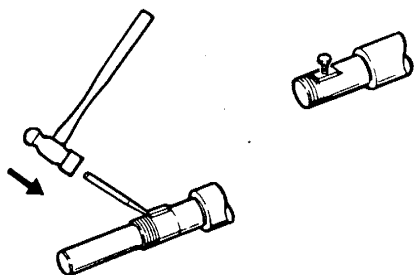
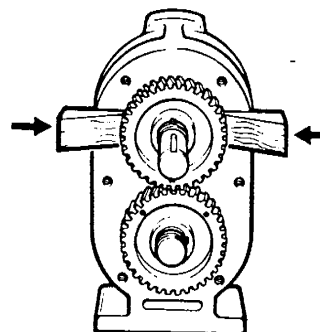

9. Remove keys from keyslots with a drift pin or jack screw. Use file to remove burrs from shaft if required.

### SHAFT REMOVAL

#### Model 2

1. Remove bearing retaining nuts using a spanner wrench or a hammer and drift.

**NOTE:** File off solder locking spot to aid in disassembly.

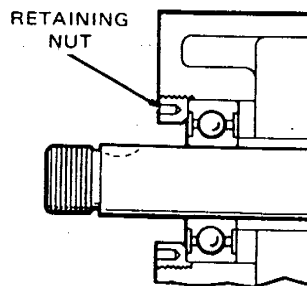



- Place bearing housing on arbor press with shaft splines up.
- Protect shaft ends with wood or plastic blocks and press out shafts. See Table 4. Protect liquid end of shafts by wrapping them with tape.

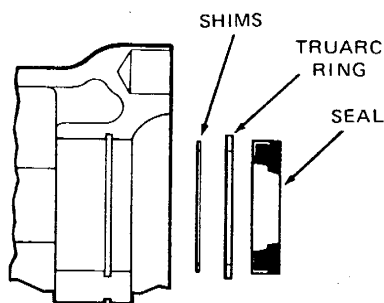
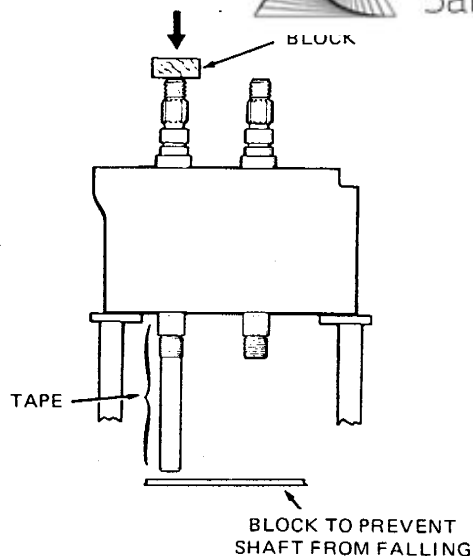

- Use a hammer and drift to drive out front seals from back side.
- Remove Truarc retaining rings and shims from housing.

- Remove rear bearings from shaft using V-blocks and an arbor press. See Table 4.
- Remove bearing spacers and press off front bearings using V-blocks and arbor press. See Table 4.

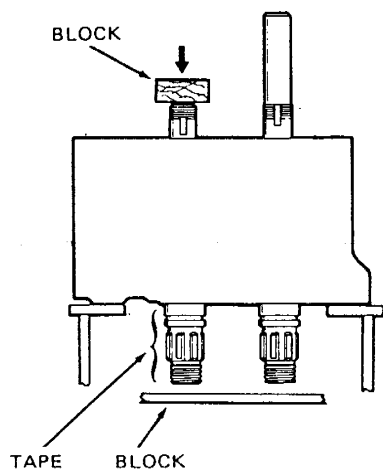
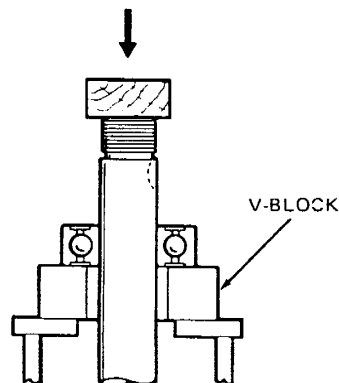

**Models 3, 10, 16, 25, 55, 100, 125 and 200**

- Protect liquid end of shafts by wrapping them with tape.
- Place housing assembly on an arbor press with liquid end down. Use wood or plastic block to protect shaft ends and press out shafts. (See Table 4.)



3. Discard wiper seals and front grease seals.
4. Remove Truarc retaining ring from shafts.

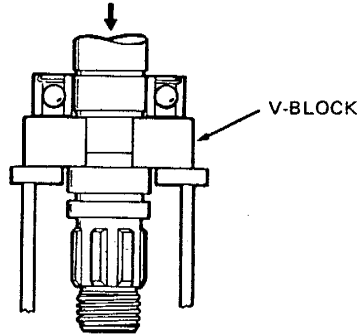
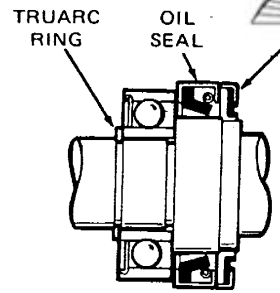

5. Remove front bearing from shaft using V-blocks and an arbor press. (See Table 4.)

6. Set housing on bench. Reach through front of housing with screw driver and remove bearing retainer bolts and retainers. Tip retainers flat to clear through front hole.

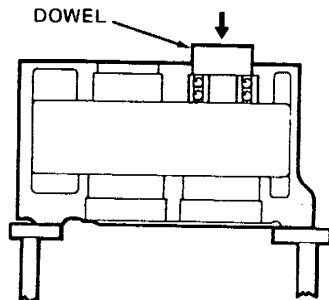
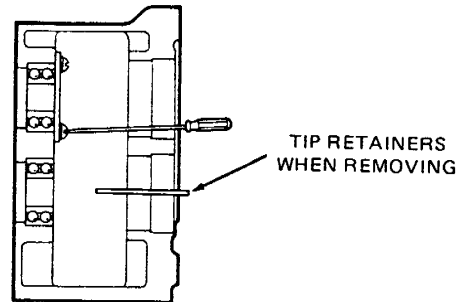

7. Return housing to arbor press and with proper diameter dowel, press out rear bearing and oil seal. Remove them through front bearing opening.
8. Clean and inspect thoroughly all parts which are to be re-used.



## SECTION IX ASSEMBLY PROCEDURES

### MODEL 2

1. Coat shaft with Molykote grease to aid assembly. Press front bearings onto shafts using an arbor or hydraulic press.

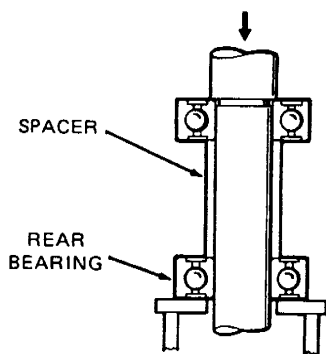
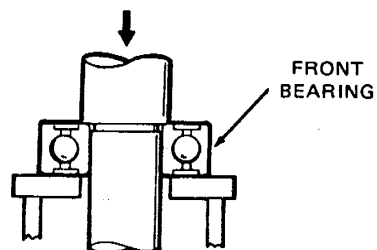

2. Slip front bearing spacer onto shaft and press on the rear bearing.

3. Install Truarc rings in housing.
4. Install shim pack in housing. (See Table 3.)
5. Coat bearing bores in housing with Molykote grease.

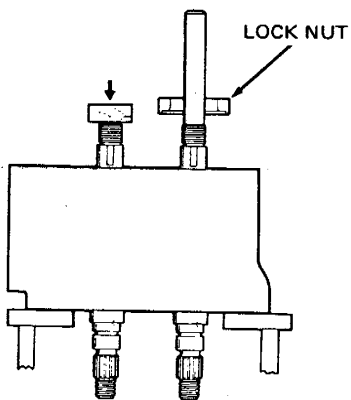
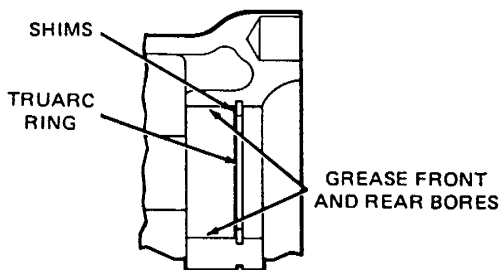

6. Press shaft assemblies into housing. Be sure drive shaft is in proper location for top or bottom drive.
7. Install bearing lock nuts to secure shaft assembly.
8. Check back face clearance. Refer to Table 1 and BACKFACE CLEARANCE, page. 46.



9. After back face clearance has been established, lock bearing lock nut with a 1/2" long solder spot.

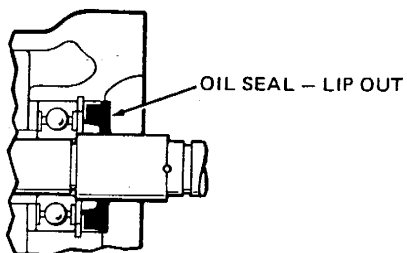
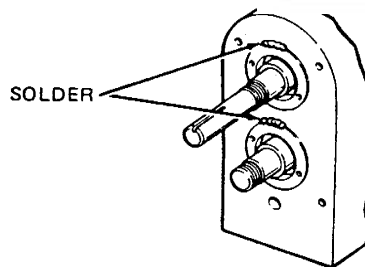

10. Press front oil seals into housing with lip out.

**MODELS 3, 10, 16, 25, 55, 100, 125 and 200**

1. Coat rear bearing bores of bearing housing with Molykote grease.

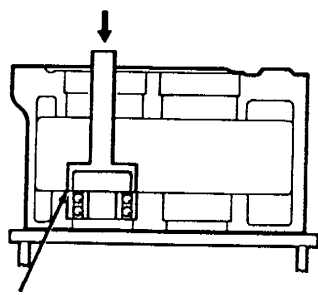
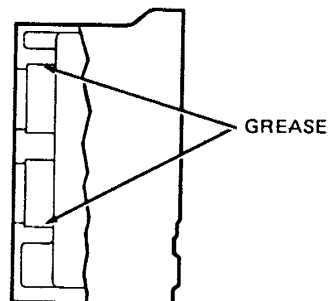

2. Press rear bearings into housing using an arbor press. (See Table 4.)

NOTE: BE SURE PUSHER CONTACTS OUTER RACE

3. Install rear bearing retainers through front bearing bores and secure with round head machine screws.

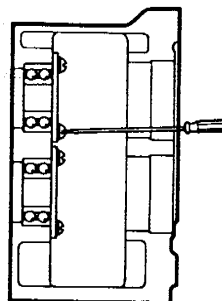

4. Grease rear bearings through grease fittings on housing with grease gun using Micro-Plate #2 grease. Pump in grease until it squirts out inside of retainers.

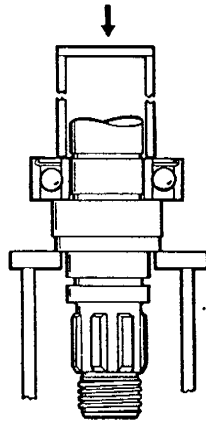
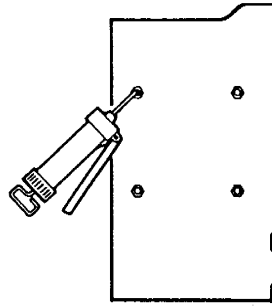

5. Coat front bearing area of the shaft with Molykote grease.

6. Press front bearings onto shafts using an arbor press. (See Table 4.)

7. Install Truarc retaining rings to lock front bearing in place.

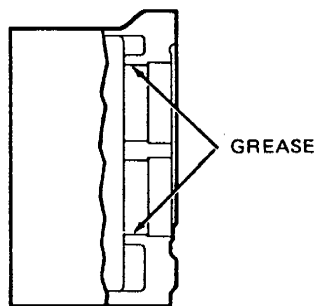
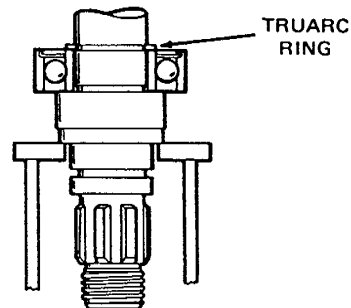

8. Coat front bearing bores with Molykote grease.

9. Place shim packs onto shafts and insert into housing. (See Table 3.)

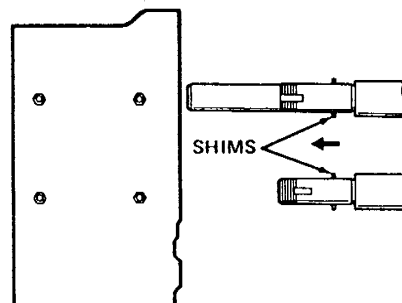



10. Place assembly onto arbor press. Using a plastic or brass plate to protect splines, press shafts into rear bearings. (See Table 4.)

**NOTE:** Install drive shaft in proper location for top or bottom drive. The gear cover is machined to match the drive shaft location and is not interchangeable.

11. Check backface clearance. Refer to Table 1 and BACKFACE CLEARANCE, page 46.

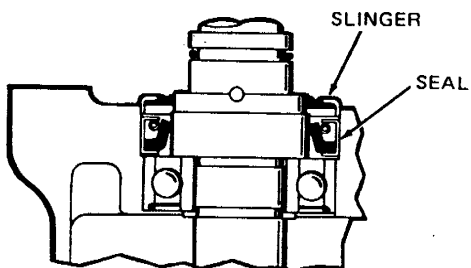
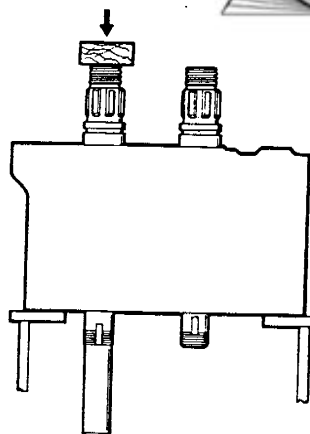

12. Press front grease seals into housing orienting sealing lip as shown.

13. Press on slingers tight against shaft shoulder.

14. Rear seal installation: Install spacer seal and spacer. Then press in rear seal flush with back face of housing.

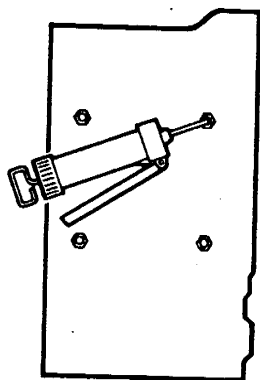
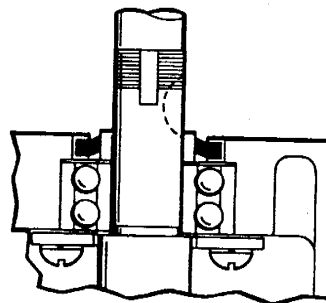

15. Grease both front and rear bearings with Micro-Plate #2 grease.



**GEAR AND GEAR COVER ASSEMBLY - ALL MODELS**

1. Place keys into shaft keyslots. Then slide gear with single punch mark onto drive shaft and the gear with two punch marks onto the short shaft with punch marks straddling single mark of drive gear.

**NOTE:** Rotors must be at right angles. Shim gears to obtain proper timing.

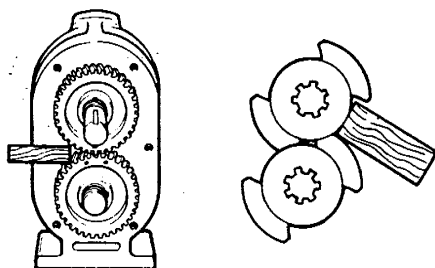
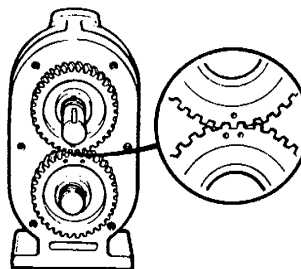

2. Secure shafts from turning with a wood block wedged between gears or rotors.

3. Apply Molykote grease to threaded area on shafts.

4. Slip on lock washers and lock nuts. Tighten lock nuts with a spanner wrench or drift. Bend locking tab to secure. See Table 2 for proper torque limit.

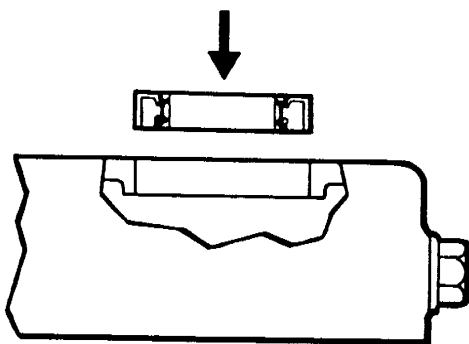
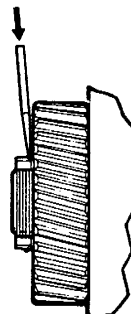

5. Press new grease seal into gear cover.  
**NOTE:** On Model 2 press in cover bearing.

6. Place gasket over gear cover and mount cover assembly over shaft extension onto bearing housing.

7. Fill gear cover with Micro-Plate #140 oil to proper level. Install vent plug.

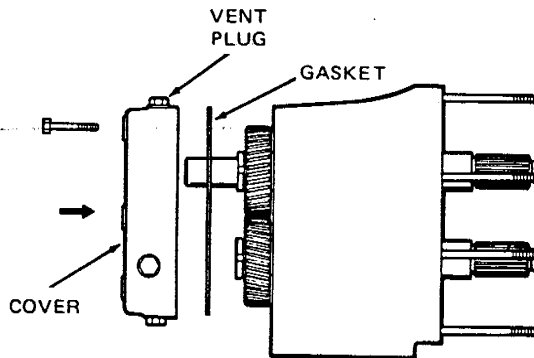





### BACK FACE CLEARANCE

1. All Waukesha Pumps are designed with close running clearances and the back face clearance is established with shims during assembly. The rotors lock against a shaft shoulder and the shaft is positioned with shims and locked into bearing housing. The resultant clearance between body back face and rotor wing is the back face clearance. (See Table 1.)

2. To check back face clearance mount body, less seals, onto housing. Assemble rotors and secure with rotor retaining nut. Measure clearance between body back face and rotor wing with feeler gauges. Check readings against recommended back face clearance in Table 1. Make note of any corrections required and follow examples to determine exact adjustment to make and avoid unnecessary assembly-disassembly.

3. To make shim adjustments it is necessary to disassemble rotors and body and remove shafts. (See Section VIII.) Make required shim adjustment and reassemble. Recheck back face clearances. Be sure both rotors have the same clearance to avoid crossover interference.

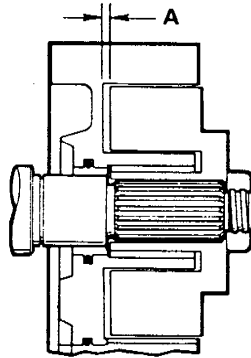
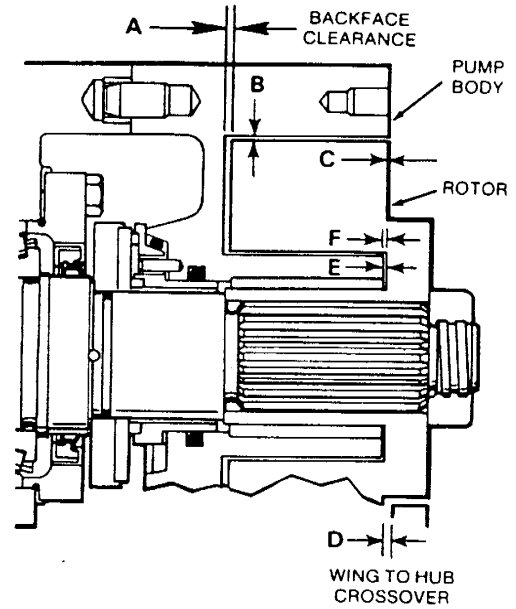

#### Too Much Clearance

Measure back face clearance (Dimension A). If clearance is greater than the clearance specified in Table 1, remove shims equal (or as close as possible) to difference between measured clearance and specified clearance.

#### Not Enough Clearance

If back face clearance is less than the clearance specified in Table 1, shims must be added. To determine amount of shims to add, use a straight edge and depth gauge and measure Dimension B between the front rotor surface and end of shaft.

Remove rotors and then the pump body. Reinstall the rotors on shafts and secure them with rotor nuts and measure Dimension C.

Add shims equal to (or as close as possible to) the difference between Dimensions B and C.

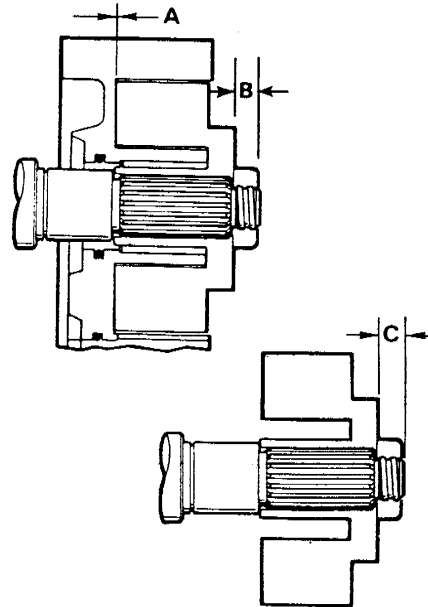

**NOTE:** Back face clearance for both rotors must be the same to avoid crossover interference with rotor hubs.

## SECTION X

# REFERENCE TABLES AND REPAIR PARTS LIST

**TABLE 1. CLEARANCES**

MODEL	A BACK FACE	B ROTOR TO BODY	C FRONT FACE	D WING TO HUB	E HUB TO HUB	F BODY HUB UNDERCUT
2	.0015	.001	.001-.002	.0005-.0015	.001-.002	ext. .004
3,10,16	.002	.0015	.002-.003	.0025-.0035	.0015-.003	.0015-.002
25	.0025	.002	.002-.003	.0015-.0025	.002-.003	.003-.0035
55,100,125	.004	.003	.0035-.0045	.0035-.0045	.0035-.005	.004-.0045
200	.005	.005	.0045-.0055	.0095-.0105	.0045-.0055	

**TABLE 2. TORQUE VALUES - FT-LBS**

MODEL	LOCK NUTS	
	BEARING	GEAR
2		60
3,10,16		75
25		100
55,100,125		140
200		230

**TABLE 3. SUGGESTED SHIMS**

MODEL	STD. PUMP	NEW SHAFT	REC. PUMP SHAFT	
			R <sub>1</sub>	R <sub>2</sub>
2	.016	.010	.080	.060
25	.016	.010	.080	.060
3,10,16	.016	.010	.080	.060
55,100,125	.016	.010	.080	.060
200	.016	.010	.080	.060

**TABLE 4. ARBOR OR HYDRAULIC PRESS REQ'D - TONS**

MODEL	SHAFT		FRONT BEARING		REAR BEARINGS			
	IN	OUT	ON	OFF	HOUSING		SHAFT	
					IN	OUT	ON	OFF
2	.25	.5	.25	.5	.25	.5		
3,10,16	.25	.5	.5	1	.5	1		
25	.25	.5	.5	1	5	1		
55,100,125	.5	1	2	5	2	5		
200	.5	1	5	10	3	5		

## VENTED COVER

### INTERNAL RELIEF VALVE

The Waukesha Vented Cover is a unique integral, compact, internal by-pass valve which can be used as a pressure relief valve. It is bi-directional; that is, the pump flow or rotation can be in either direction. However, the combinations of flow, pressure, and viscosity which may be encountered may exceed the by-pass capability of the vented cover passages. Specific operating conditions should be furnished to Waukesha Pumps for recommendations.

Three types of "Vented Cover" are available:

#### 1. Manual

By-pass pressure is adjusted by a threaded adjusting screw (2) which compresses a spring (5). Several spring sizes are available, each with limited operating range.

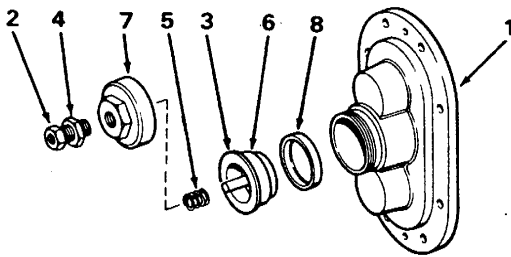

#### 2. Pneumatic

By-pass pressure is adjusted by regulated air or gas pressure, operating on the side of a diaphragm (9) opposite the pumped fluid. Most sensitive control of the three types.

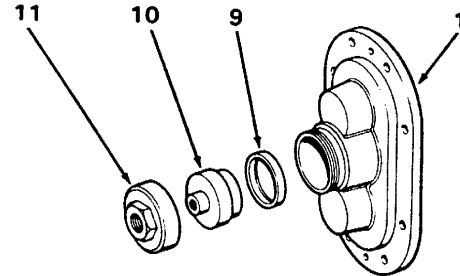

TYPE	ITEM	DESCRIPTION	QTY.	PART NUMBER BY MODEL					
				2	3, 10, 16	25	55, 100, 125	200	
MANUAL		Cover Assembly		002-002-V00	010-002-V00	025-002-V00	055-002-V00	210-002-V10	
	1	Pump Cover	1	FBB-002-V00	ADO-002-VS0	BDO-002-VS0	CDO-002-VS0	GDO-002-VS0	
	2	Adjusting Screw	1	FBB-072-000	ADO-072-000	ADO-072-000	ADO-072-000	GDO-072-100	
	3	Spring Plunger	1	FBB-073-000	ADO-073-000	ADO-073-000	ADO-073-000	GDO-073-000	
	4	Locknut	1	FBB-074-000	ADO-074-000	ADO-074-000	ADO-074-000	GDO-074-000	
	5	Spring	Low	1	ADO-076-L00	ADO-076-L00	ADO-076-000	ADO-076-000	---
			Medium	1	ADO-076-000	ADO-076-000	ABB-076-100	ABB-076-100	---
			High	1	ABB-076-100	ABB-076-100	ABB-076-200	ABB-076-200	GDO-076-100
	6	Diaphragm Bushing	1	FBB-077-000	ADO-077-000	ADO-077-000	CDO-077-000	GDO-077-000	
7	Cover Nut	1	FBB-075-000	ADO-075-000	ADO-075-000	CDO-075-000	GDO-075-000		
8	Rubber Diaphragm	1	FBB-078-000	ADO-078-000	ADO-078-000	CDO-078-000	GDO-078-000		
PNEUMATIC		Cover Assembly		002-002-VP0	010-002-VP0	025-002-VP0	055-002-VP0	---	
	1	Vented Cover	1	FBB-002-V00	ADO-002-VS0	BDO-002-VS0	CDO-002-VS0	---	
	9	Diaphragm	1	FBB-078-000	ADO-078-000	ADO-078-000	CDO-078-000	---	
	10	Diaphragm Bushing	1	FBB-077-P00	ADO-077-P00	ADO-077-P00	CDO-077-P00	---	
	11	Cover Nut	1	FBB-075-P00	ADO-075-P00	ADO-075-P00	CDO-075-P00	---	
PISTON		Cover Assembly		---	010-002-VP1	025-002-VP1	055-002-VP1	210-002-VP1	
	1	Vented Cover	1	---	ADO-002-VS0	BDO-002-VS0	CDO-002-VS0	GDO-002-VS0	
	12	Piston	1	---	ADO-073-P10	ADO-073-P10	CDO-073-P10	GDO-073-P10	
	13	Bushing Seal	1	---	ADO-133-200	ADO-133-200	CDO-133-200	BDO-117-000	
	14	Diaphragm Bushing	1	---	ADO-077-P10	ADO-077-P10	CDO-077-P10	GDO-077-P10	
	15	Nut Seal	1	---	ADO-133-100	ADO-133-100	CDO-133-100	BDO-117-000	
	16	Cover Nut	1	---	ADO-075-P10	ADO-075-P10	CDO-075-P10	GDO-075-P10	
	17	Piston Seal	1	---	ADO-133-000	ADO-133-000	CDO-133-000	GDO-133-000	

### 3. Piston

By-pass pressure is adjusted by regulated air or gas pressure, operating on the side of a metal piston (12), opposite the pumped fluid. Extended pressure range possible.

**NOTE:** On all types of relief valve covers the temperature and chemical resistance of the elastomer diaphragms and "O" rings determine the useful range.

Buna-N ..... Material supplied as standard  
 Silicone Rubber ..... Optional material upon request

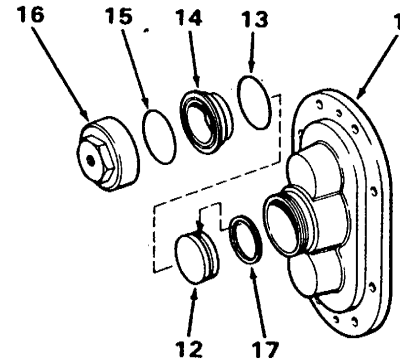

## INSTALLATION ADJUSTMENT

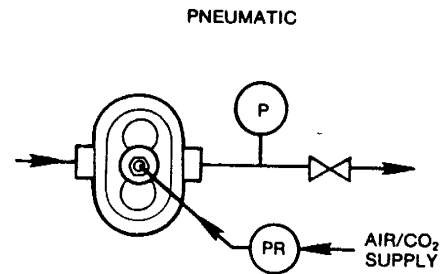
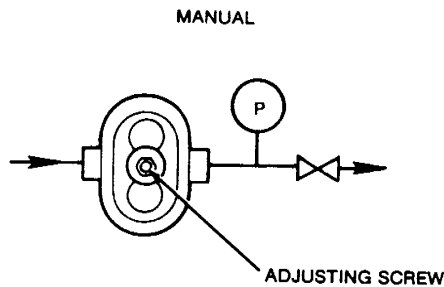

1. Manual: Turn adjusting screw counterclockwise to its farthest position, then clockwise until light spring pressure is felt.

1. Pneumatic and Piston: Set air/gas regulator at 2-5 PSI on relief valve.

2. Turn on pump.

3. Manual:

With pressure gauge and valve in discharge line.

- a. Close discharge valve.
- b. Turn adjusting screw clockwise until desired relief pressure registers on gauge. Lock adjusting screw with lock nut.
- c. Open valve in discharge line. Relief valve is set and will open if system pressure exceeds preset limit.

Without pressure gauge in discharge line.

- a. Turn adjusting screw clockwise and observe product flow at discharge of system.
- b. When product flow reaches maximum or desired flow rate, lock adjusting screw with lock nut.

3. Pneumatic and Piston:

With pressure gauge and valve in discharge line.

- a. Close discharge valve slowly and observe gauge pressure. **DO NOT ALLOW PRESSURE TO EXCEED 150 PSI.**
- b. Increase air/gas pressure to relief valve, with regulator, until desired relief pressure registers on gauge. Lock regulator adjusting screw with lock nut.
- c. Open valve in discharge line. Relief valve is set and will open if system pressure exceeds preset limit.

Without pressure gauge in discharge line.

- a. Increase air/gas pressure to relief valve, with regulator, and observe product flow at discharge of system.
- b. When product flow reaches maximum or desired flow rate, lock regulator adjusting screw with lock nut.



### JACKETED COVER

Available On Models 2, 3, 10, 16, 25, 55, 60, 100, 125

The Jacketed Cover is designed to allow circulation of a heating or cooling medium. The purpose is to help pre-heat or cool the pumping head and sustain operating temperature during short shut down periods. It should not be used as a heat exchanger to control pumping temperature during operation.

**NOTE:** Pressure limit for cover media is 60 PSI.

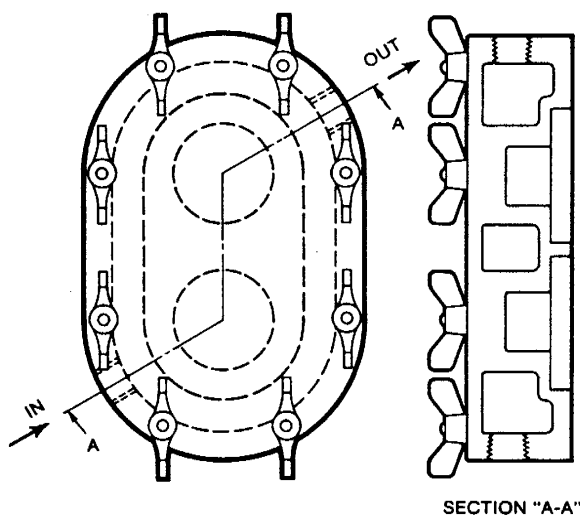

#### CONNECTIONS

Model Number	
2, 3, 10, 16 and 25	55, 60, 100, 125
3/4" Pipe Tap	1" Pipe Tap

### PUMP JACKETS

Split Cast Aluminum Jackets with cast in pipe passages are available for higher pressures and temperatures. Consult factory for recommendations.

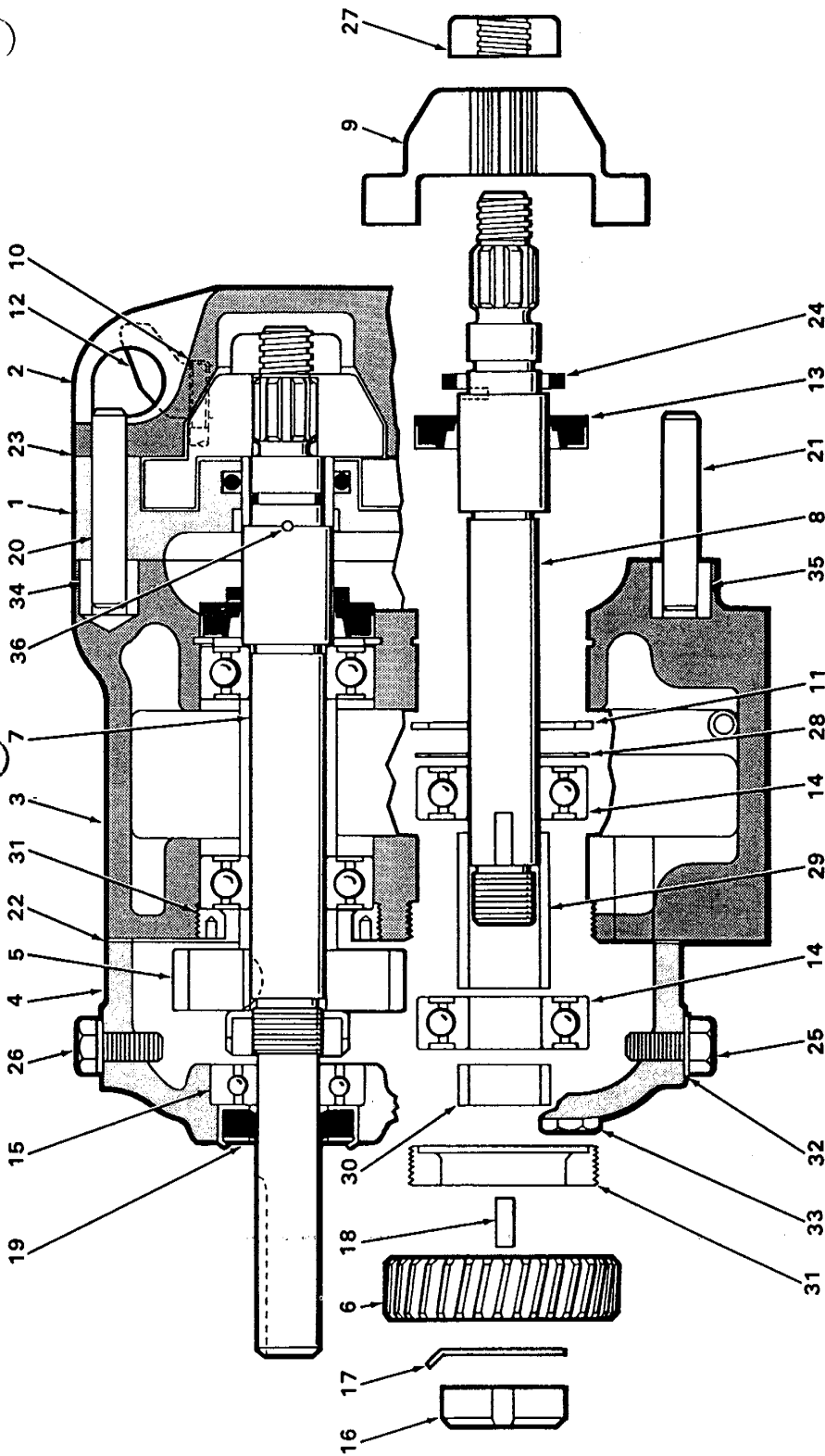

**MODEL 2-BB**

Item	Description	Qty	Part No.	Item	Description	Qty	Part No.
1	Body	1	FBB-001-000	33	Hex Cap Screw	4	ADO-081-000
2	Cover - Vented*	1	FBB-002-000	34	Dowel Bushing - Upper	1	FBB-116-000
3	Bearing Housing	1	002-002-000	35	Dowel Bushing - Lower	1	FBB-116-100
4	Gear - Drive Shaft	1	FBB-005-000	36	Drive Pin	2	FBB-126-000
5	Gear - Short Shaft	1	FBB-006-000				
6	Drive Shaft	1	FBB-007-H10		OIL MICRO-PLATE #140		
7	Short Shaft	1	FBB-007-H20		1 - Gallon Can		OBI-140-000
8	Rotor	1	FBB-008-010		1 - Quart Can		OBI-141-000
9	Stud	1	FBB-009-010		GREASE MICRO-PLATE #2		OBI-142-000
10	Truarc Ring	4	FBB-010-200		1 - Pound Tube		
11	Wing Nut	2	FBB-011-000		"O" Ring Tool		ADO-096-001
12	Oil Seal	4	ADO-016-000		Rotor Nut Wrench		FBB-019-000
13	Bearing - Bearing Housing	2	FBB-013-000		†Not Shown		
14	Bearing - B.H. Cover	4	FBB-030-000		*See Vented Cover Section, page 34, for Assembly Options and Parts Breakdown.		
15	Lock Nut	1	FBB-036-000				
16	Lock Nut	2	FBB-036-N00				
17	Lockwasher	17	FBB-036-W00				
18	Key - Gear	2	FBB-037-000				
19	Oil Seal - B.H. Cover	1	FBB-038-000				
20	Dowel Pin - Upper	1	FBB-040-000				
21	Dowel Pin - Lower	1	FBB-040-A00				
22	Gasket - B.H. Cover	1	FBB-043-000				
23	Gasket - P.C.	1	FBB-042-A00				
24	Slinger	2	FBB-045-800				
25	Cap Screw - Oil Level - Drain	5	ADO-046-000				
26	Breather Cap Screw	1	ADO-046-100				
27	Rotor Nut	2	FBB-052-000				
28	Shim (.002 & .006)	As Req'd.	FBB-054-000				
29	Spacer - Front	2	FBB-055-000				
30	Spacer - Rear	2	FBB-055-A00				
31	Bearing Ret. Nut	2	FBB-057-000				
32	Fiber Washer	6	BDO-065-000				

# MODEL 2 SEAL

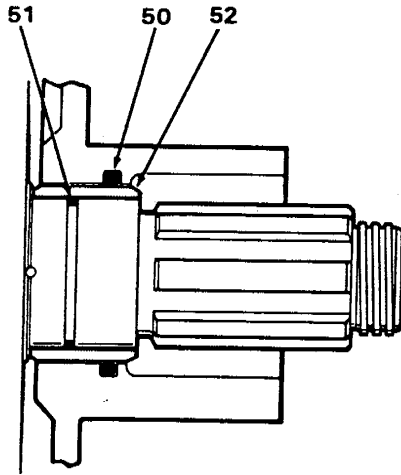

## MODEL DO "O" RING SEAL

Item	Description	Qty	Part No.
50	"O" Ring - Body - Buna N	2	FBB-079-000
	"O" Ring - Body - Viton	2	FBB-079-V00
	"O" Ring - Body - E.P.	2	FBB-079-002
51	"O" Ring - Shaft - Buna N	2	FBB-097-000
52	Sleeve - Prong Type	2	FBB-098-001



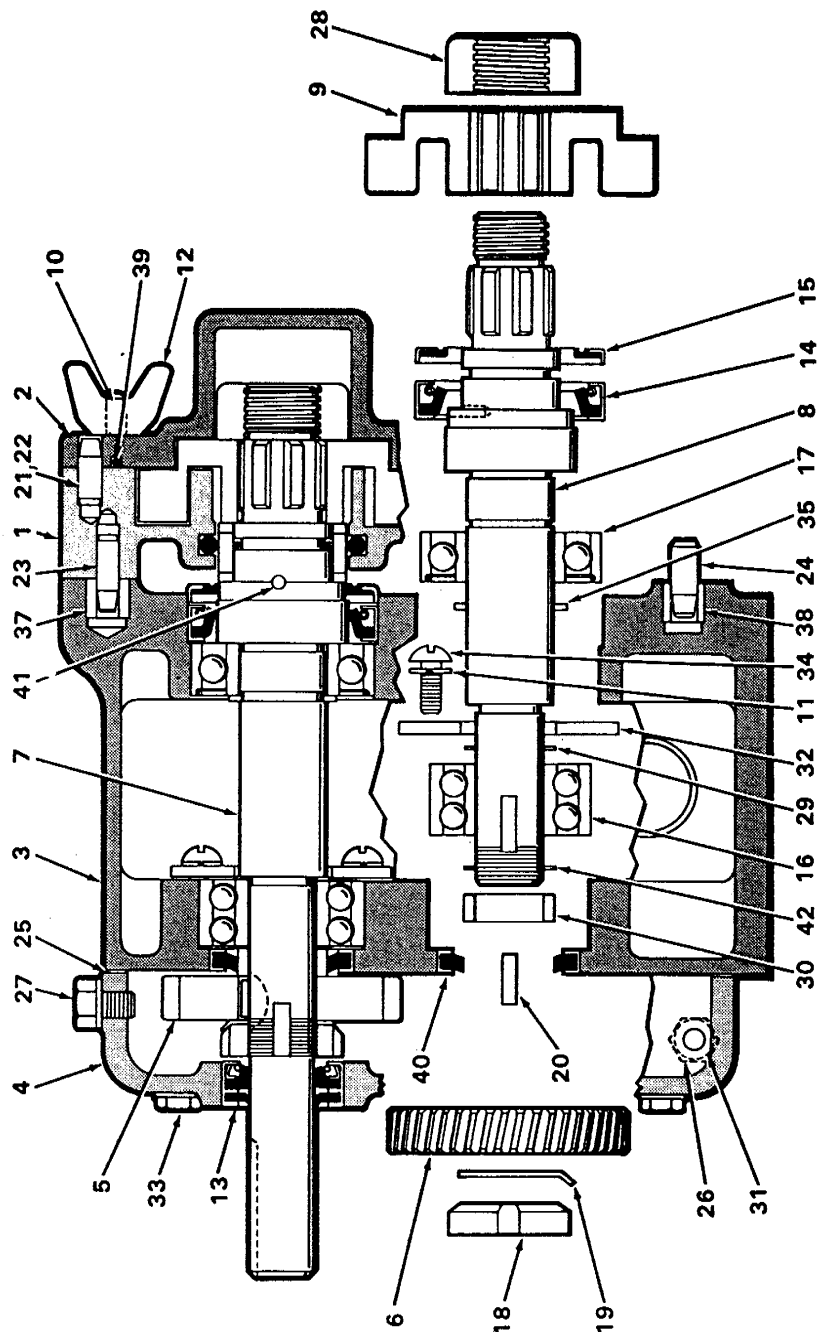

**MODEL 3-DO**

Item	Description	Qty	Part No.	Item	Description	Qty	Part No.	Item	Description	Qty	Part No.
1	Body	1	AD0-001-300	19	Lockwasher - Gear	2	AD0-036-W00	39	"O" Ring - Cover - Buna N	1	AD0-117-000
2	Cover - Vented*	1	AD0-002-S00	20	Woodruff Key - Gear	2	AD0-037-000		"O" Ring - Cover - Viton	1	AD0-117-V00
3	Cover - Jacketed	1	010-002-V00	21	Dowel Pin - Upper	1	AD0-040-000		"O" Ring - Cover - Silicone	1	AD0-117-SC0
4	Bearing Housing	1	AD0-002-J10	22	Dowel Pin - Lower	1	AD0-040-100		"O" Ring - Cover - Teflon	1	AD0-117-T00
5	Bearing Housing - Upper	1	AD0-105-000	23	Dowel Pin Body - Upper	1	AD0-040-R10	40	Oil Seal - Rear	2	AD0-119-000
6	Bearing Housing - Lower	1	AD0-105-U00	24	Dowel Pin Body - Lower	1	AD0-040-R10	41	Drive Pin	2	AD0-126-000
7	Gear - Drive Shaft	1	AD0-105-L00	25	Gasket - B.H. Cover	1	AD0-042-000	42	Spacer Seal	2	AD0-127-000
8	Gear - Short Shaft	1	AD0-007-H10	26	Hex Cap Screw	2	AD0-046-000		OIL MICRO-PLATE #140		
9	Drive Shaft	1	AD0-007-H20	27	Breather Screw	1	AD0-046-100		1 - Gallon Can		081-140-000
10	Short Shaft	1	AD0-008-000	28	Rotor Retaining Nut	2	AD0-052-000		1 - Quart Can		081-141-000
11	Rotor - Twin Blade	2	AD0-010-230	29	Shim (.002 & .006)	As Reqd.	AD0-054-000		GREASE MICRO-PLATE #2		
12	Lockwasher	8	AD0-011-000	30	Spacer	2	AD0-055-000		1 - Pound Tube		081-142-000
13	Wing Nut	8	AD0-013-000	31	Fiber Washer	3	B00-065-000		"O" Ring Tool		AD0-095-001
14	Oil Seal - B.H. Cover	1	AD0-016-000	32	Bearing Retaining Plate	2	AD0-080-000		Rotor Nut Wrench		AD0-019-000
15	Oil Seal - Front	1	AD0-030-000	33	Hex Cap Screw	6	AD0-081-000		†Not Shown		
16	Wiper Seal	2	AD0-030-100	34	Rd. Hd. Cap Screw	8	B00-083-000		*See Vented Cover Section, page 34, for Assembly Options and Parts Breakdown.		
17	Bearing - Rear	2	AD0-030-1W0	35	Truarc Ring	2	AD0-087-R00				
18	Bearing - Front	2	015-035-000	36	Grease Fitting	4	B00-092-000				
	Lock Nut - Gear	2	AD0-036-N00	37	Dowel Bush - Upper	1	AD0-116-000				
				38	Dowel Bush - Lower	1	AD0-116-100				



# MODEL 3 SEAL



**TRIPLEX**  
Sales Company

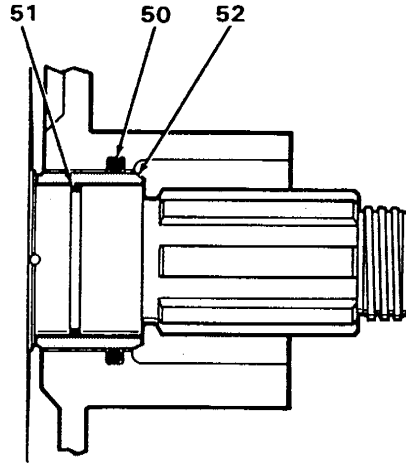

## MODEL DO "O" RING SEAL

Item	Description	Qty	Part No.
50	"O" Ring Body - Buna N	2	ADO-079-000
	"O" Ring Body - Viton	2	ADO-079-V00
	"O" Ring Body - Silicone	2	ADO-079-SC0
	"O" Ring Body - E.P.	2	ADO-079-002
	U-Cup Body - Buna N	2	ADO-079-U00
51	"O" Ring - Shaft - Buna N	2	ADO-097-000
	"O" Ring - Shaft - Viton	2	ADO-097-V00
	"O" Ring - Shaft - Silicone	2	ADO-097-002
52	Sleeve - Prong	2	ADO-098-001

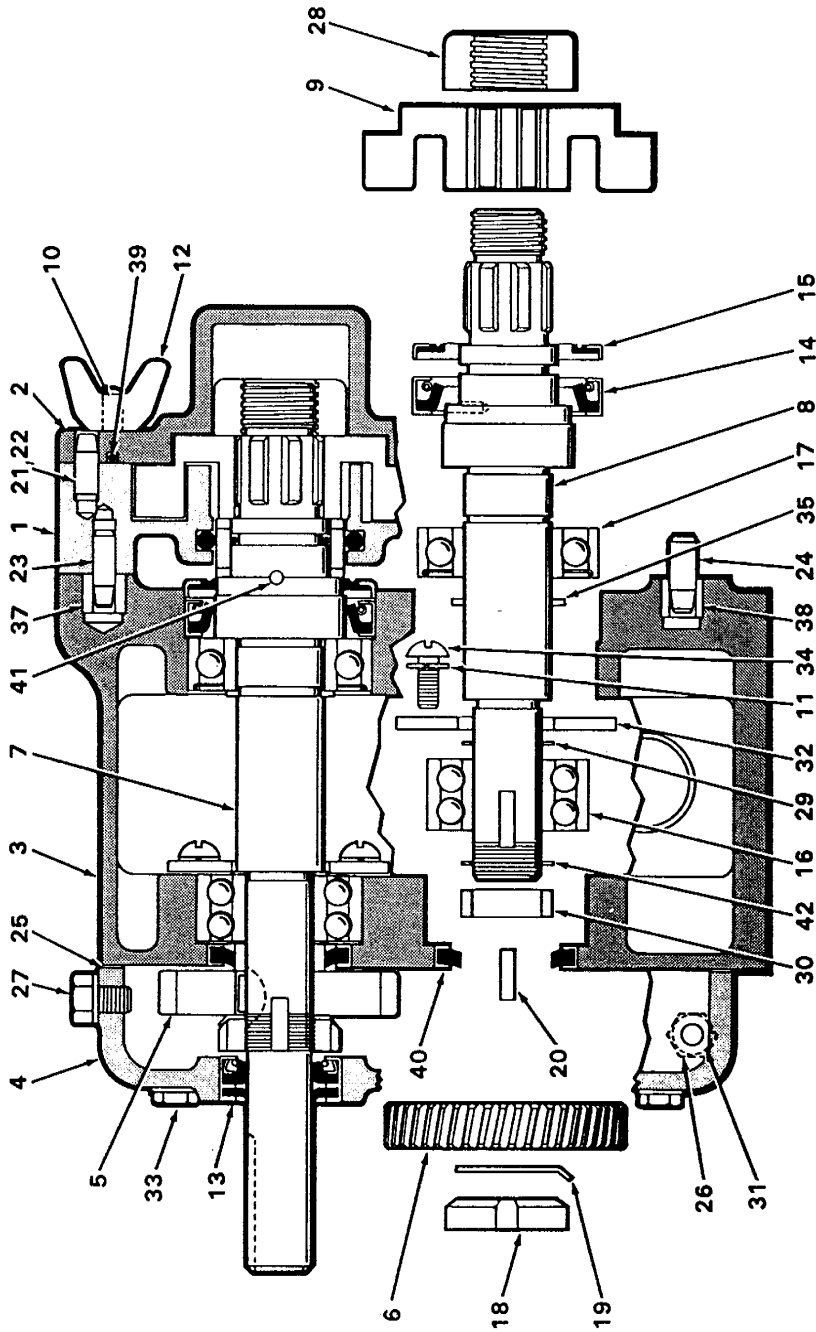

**MODELS 10-DO AND 10-GT**

Item	Description	Qty	Part No.	Item	Description	Qty	Part No.	Item	Description	Qty	Part No.
1	Body - DO	1	AD0-001-0S0	17	Bearing - Front	2	015-035-000	38	Dowel Bush. - Lower	1	AD0-116-100
2	Body - GT	1	AGT-001-000	18	Locknut - Gear	2	AD0-036-N00	39	"O" Ring - Cover - Buna N	1	AD0-117-000
3	Cover - Jacketed*	1	AD0-002-S00	19	Lockwasher - Gear	2	AD0-036-W00		"O" Ring - Cover - Viton	1	AD0-117-000
4	Cover - Vented*	1	AD0-002-V00	20	Key - Gear	2	AD0-037-000		"O" Ring - Cover - Silicone	1	AD0-117-SC0
5	Bearing Housing	1	AD0-002-J10	21	Dowel Pin - Upper	1	AD0-040-000	40	"O" Ring - Cover - Teflon	1	AD0-117-T00
6	B.H. Cover - Upper	1	AD0-105-000	22	Dowel Pin - Lower	1	AD0-040-100	41	Oil Seal - Rear	2	AD0-119-000
7	B.H. Cover - Lower	1	AD0-105-U00	23	Dowel Pin Body - Upper	1	AD0-040-R00	42	Drive Pin	2	CD0-126-000
8	Gear - Drive Shaft	1	AD0-106-L00	24	Dowel Pin Body - Lower	1	AD0-040-R10		Spacer Seal	2	AD0-127-000
9	Gear - Short Shaft	1	AD0-007-H10	25	Gasket - B.H. Cover	1	AD0-042-000		OIL MICRO-PLATE #140		
10	Drive Shaft - DO	1	AD0-007-H20	26	Cap Screw	2	AD0-046-000		1 - Gallon Can		
11	Drive Shaft - GT	1	AD0-008-000	27	Breather Screw	1	AD0-046-100		1 - Quart Can		
12	Short Shaft - DO	1	AGT-008-000	28	Rotor Nut	2	AD0-052-000		GREASE MICRO-PLATE #2		
13	Short Shaft - GT	1	AGT-009-000	29	Shims (.002 & .006)	As	AD0-054-000		1 - Pound Tube		
14	Rotor - Twin Blade	2	AD0-010-000	30	Spacer	Reqd.			"O" Ring Removal Tool		
15	Stud	8	AD0-011-000	31	Fiber Washer	2	AD0-055-000		Rotor Nut Wrench		
16	Lockwasher	8	BDO-013-000	32	Bearing Retainer Plate	2	BDO-065-000		+Not Shown		
17	Wing Nut	8	AD0-016-000	33	Hex Cap Screw	6	AD0-080-000		*See Vented Cover Section, page 34, for Assembly Options and Parts Breakdown.		
18	Oil Seal - B.H. Cover	1	AD0-030-000	34	Rd. Hd. Cap Screw	8	AD0-081-000				
19	Wiper Seal	2	AD0-030-100	35	Truarc Ring	2	BDO-083-000				
20	Bearing - Rear	2	AD0-030-1W0	36	Grease Fitting	4	AD0-087-R00				
21		2	AD0-036-000	37	Dowel Bush. - Upper	1	BDO-092-000				



**MODEL 10 SEAL OPTIONS**

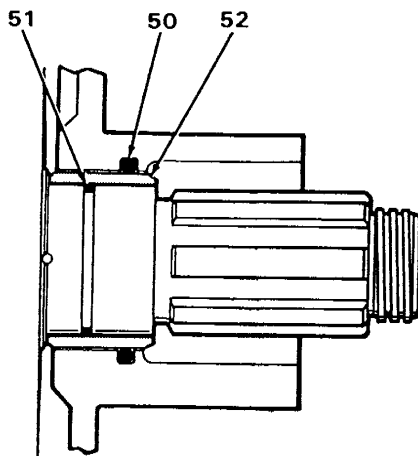

**MODEL DO "O" RING SEAL**

Item	Description	Qty	Part No.
50	"O" Ring - Body - Buna N	2	ADO-079-000
	"O" Ring - Body - Viton	2	ADO-079-V00
	"O" Ring - Body - Silicone	2	ADO-079-SC0
	"O" Ring - Body - E.P.	2	ADO-079-002
	U-Cup - Body - Buna N	2	ADO-079-U00
51	"O" Ring - Shaft - Buna N	2	ADO-097-000
	"O" Ring - Shaft - Viton	2	ADO-097-V00
	"O" Ring - Shaft - Silicone	2	ADO-097-SC0
52	Sleeve - Prong	2	ADO-098-001

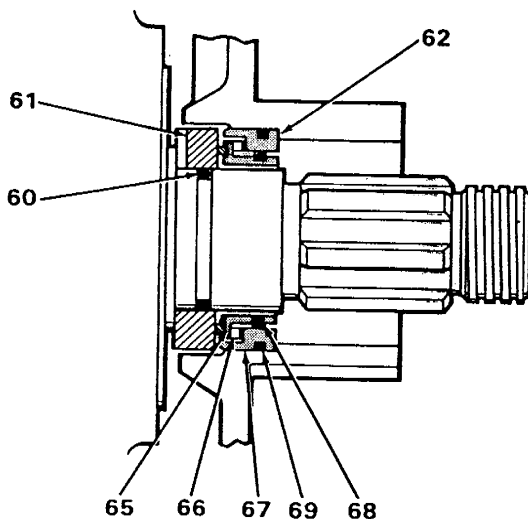

**MODEL GT MECHANICAL SEAL**

Item	Description	Qty	Part No.
60	"O" Ring - Shaft - Buna N	2	ADO-097-000
	"O" Ring - Shaft - Viton	2	ADO-097-V00
	"O" Ring - Shaft - Silicone	2	ADO-097-SC0
61	Seal Seat - Carp. 20	2	AMF-014-000
62	Seal Case Assembly**	2	AGT-305-101
	Carbon Carrier Assembly**	2	AGT-306-101

**\*\*Seal Assembly Breakdown**

65	Carrier - Carbon	2	AGT-306-000
66	Wave Spring	2	AGT-304-000
67	Seal Case	2	AGT-305-000
68	"O" Ring - Carrier - Buna N	2	870-137-123
69	"O" Ring - Case - Buna N	2	870-137-128

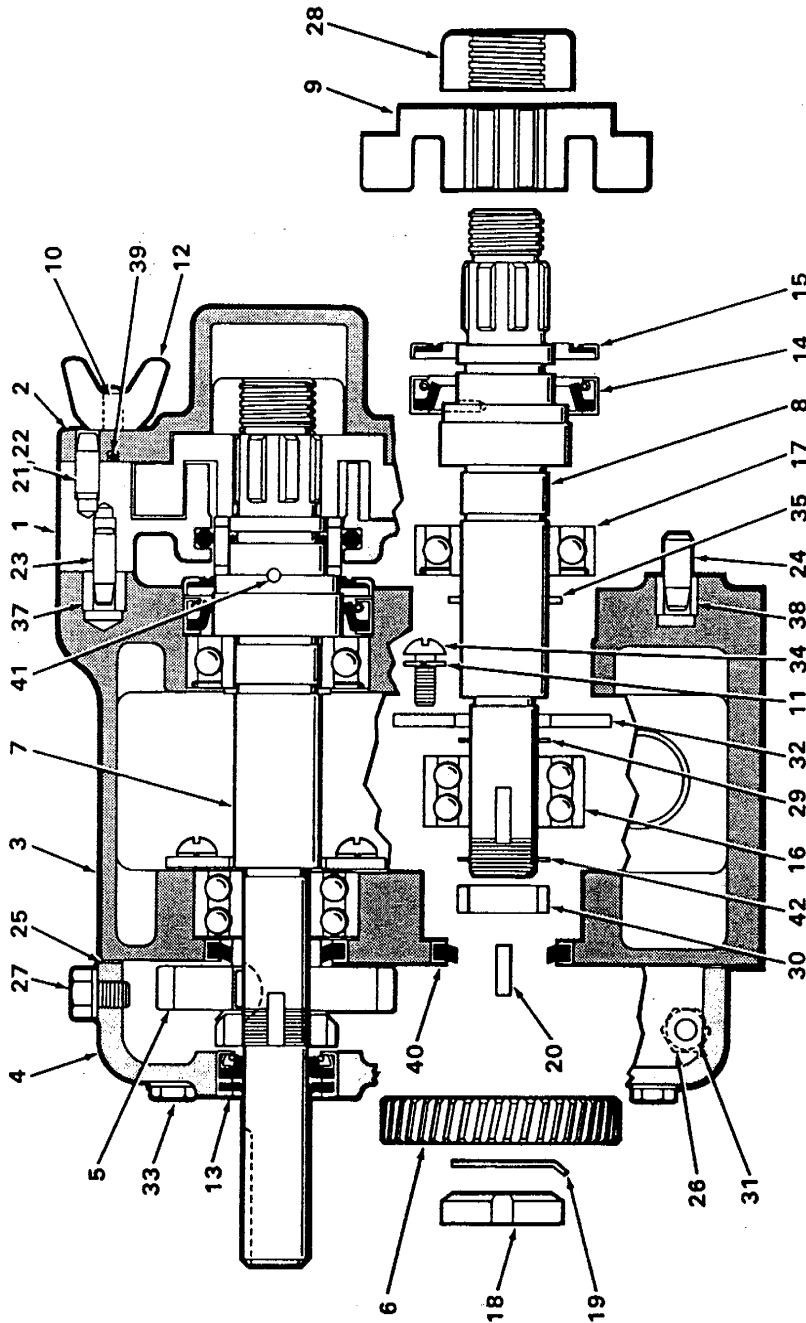

**MODEL 16-DO**

Item	Description	Qty	Part No.	Item	Description	Qty	Part No.	Item	Description	Qty	Part No.
1	Body	1	ADO-001-160	19	Lockwasher - Gear	2	ADO-036-W000	39	"O" Ring - Cover - Buna N	1	ADO-117-000
2	Cover - Vented*	1	ADO-002-S00	20	Woodruf Key - Gear	2	ADO-037-000		"O" Ring - Cover - Viton	1	ADO-117-V00
3	Cover - Jacketed	1	010-002-V00	21	Dowel Pin - Upper	1	ADO-040-000		"O" Ring - Cover - Silicone	1	ADO-117-S00
4	Bearing Housing Cover - Upper	1	ADO-002-J10	22	Dowel Pin - Lower	1	ADO-040-100		"O" Ring - Cover - Teflon	1	ADO-117-T00
5	Bearing Housing Cover - Lower	1	ADO-105-000	23	Dowel Pin Body - Upper	1	ADO-040-R00		Oil Seal - Rear	2	ADO-119-000
6	Drive Shaft	1	ADO-106-100	24	Dowel Pin Body - Lower	1	ADO-040-R10		Drive Pin	2	CDO-126-000
7	Short Shaft	1	ADO-106-100	25	Gasket - B.H. Cover	1	ADO-042-000		Spacer Seal	2	ADO-127-000
8	Drive Shaft	1	ADO-007-H10	26	Hex Cap Screw	1	ADO-046-100		OIL MICRO-PLATE #140		
9	Rotor - Twin Blade	1	ADO-008-160	27	Breather Screw	2	ADO-052-000		1 - Gallon Can		
10	Lockwasher	2	ADO-009-160	28	Rotor Retaining Nut	1	ADO-052-000		1 - Quart Can		
11	Lockwasher	2	ADO-010-160	29	Shim (.002 & .006)	As Reqd.	ADO-054-000		GREASE MICRO-PLATE #2		
12	Wing Nut	8	ADO-011-160	30	Spacer	2	ADO-055-000		1 - Pound Tube		
13	Oil Seal - B.H. Cover	6	BDO-013-000	31	Fiber Washer	2	BDO-065-100		"O" Ring Removal Tool		
14	Oil Seal - Front	8	ADO-016-000	32	Bearing Retaining Plate	3	ADO-080-000		Rotor Nut Wrench		
15	Wiper Seal	1	ADO-030-100	33	Hex Cap Screw	6	ADO-081-000				
16	Bearing - Rear	2	ADO-030-100	34	Rd. Hd. Cap Screw	8	BDO-083-000				
17	Bearing - Front	2	ADO-030-1W0	35	Truarc Ring	2	ADO-087-R00				
18	Lock Nut - Gear	2	ADO-035-000	36	Grease Fitting	4	BDO-092-000				
			015-035-000	37	Dowel Bush. - Upper	1	ADO-116-000				
			ADO-036-N00	38	Dowel Bush. - Lower	1	ADO-116-100				

\*Not Shown  
\*See Vented Cover Section, page 34, for Assembly Options and Parts Breakdown.

MODEL 16 SEAL



**TRIPLEX**  
Sales Company

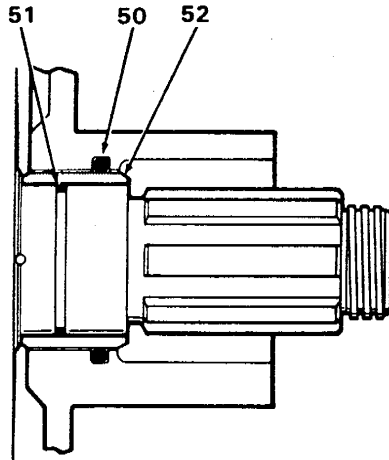

**MODEL DO "O" RING SEAL**

Item	Description	Qty	Part No.
50	"O" Ring - Body - Buna N	2	ADO-079-000
	"O" Ring - Body - Viton	2	ADO-079-V00
	"O" Ring - Body - Silicone	2	ADO-079-SC0
	"O" Ring - Body - E.P.	2	ADO-079-002
	U-Cup - Body - Buna N	2	ADO-079-U00
51	"O" Ring - Shaft - Buna N	2	ADO-097-000
	"O" Ring - Shaft - Viton	2	ADO-097-V00
	"O" Ring - Shaft - Silicone	2	ADO-097-002
52	Sleeve - Prong	2	ADO-098-001

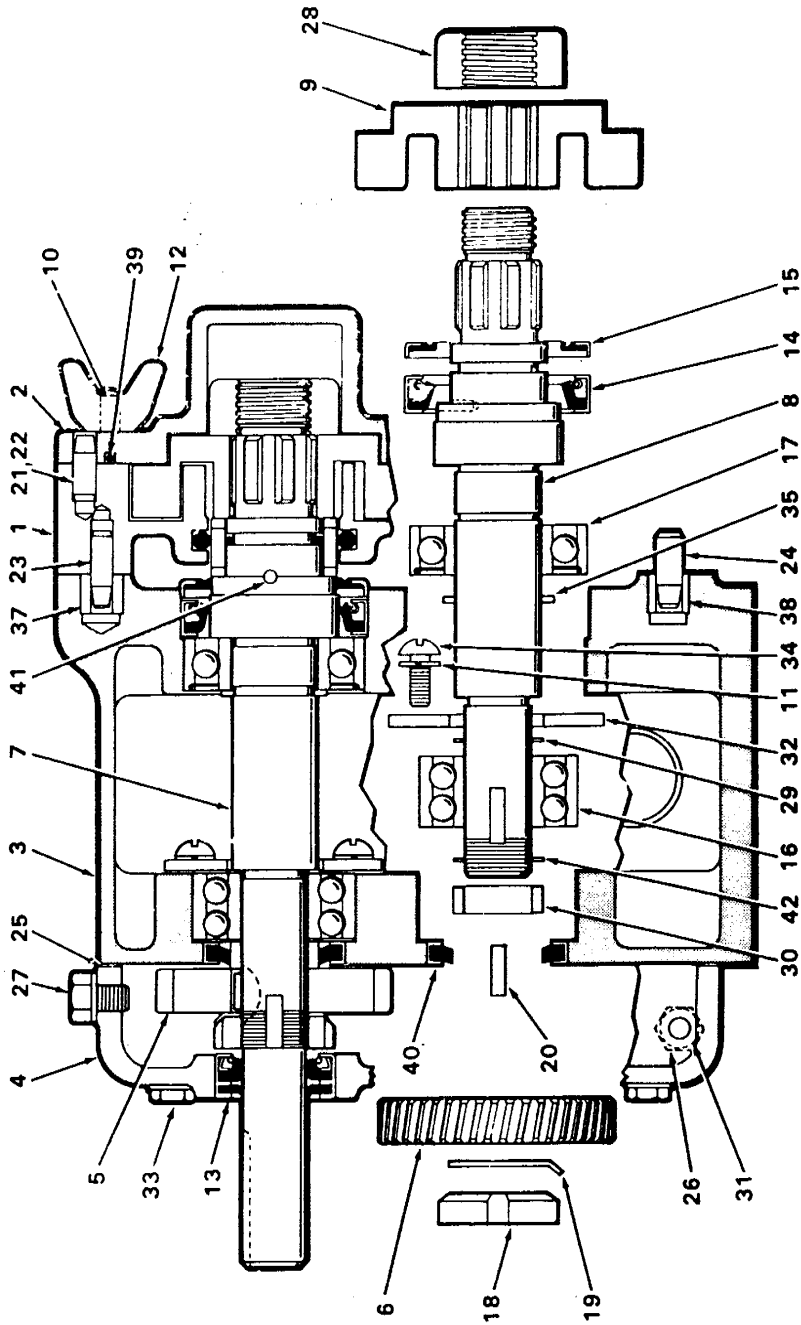

**MODELS 25-DO, 25-TO AND 25-GT**

Item	Description	Qty	Part No.	Item	Description	Qty	Part No.	Item	Description	Qty	Part No.
1	Body - DO		B00-001-050	15	Wiper Seal	2	B00-030-1W0	36	Grease Fitting	4	B00-092-000
2	Body - TO		B00-001-100	16	Bearing - Rear	2	B00-036-000	37	Dowel Bush - Upper	1	B00-116-000
3	Body - GT		B00-001-070	17	Bearing - Front	2	B00-035-300	38	Dowel Bush - Lower	1	B00-116-100
4	Cover		B00-002-500	18	Lock Nut - Gears	2	B00-036-N00	39	"0" Ring - Cover - Buna N	1	B00-117-000
5	Cover - Jacketed		025-002-V00	19	Lockwasher - Gears	2	B00-036-W00	40	"0" Ring - Cover - Viton	1	B00-117-900
6	Bearing Housing - Side Mt.		B00-002-J10	20	Key - Gear	2	B00-037-000	41	"0" Ring - Cover - Silicone	1	B00-117-SC0
7	Bearing Housing - Upper		B00-105-SM0	21	Dowel Pin - Upper	1	B00-040-000	42	Oil Seal - Rear	2	B00-119-000
8	Bearing Housing - Lower		B00-105-SM0	22	Dowel Pin - Lower	1	B00-040-100		Drive Pin	2	B00-126-000
9	Bearing Housing - Cover - Upper		B00-106-J00	23	Dowel Pin Body - Upper	1	B00-040-200		Spacer Seal	2	B00-127-000
10	Bearing Housing - Cover - Lower		B00-106-L00	24	Dowel Pin Body - Lower	1	B00-040-300				
11	Bearing Housing - Cover - Side Mt.		B00-106-SM0	25	Dowel Pin - B.H. Cover	1	B00-042-SM0				
12	Gear - Drive Shaft		B00-007-H10	26	Gasket - B.H.C. Side Mt.	1	B00-042-SM0				
13	Gear - Short Shaft		B00-007-H20	27	Hex Cap Screw	2	B00-046-000				
14	Drive Shaft - DO		B00-008-100	28	Breather Screw	1	B00-046-100				
15	Drive Shaft - TO, GT		B00-008-100	29	Rotor Retaining Nut	2	B00-052-000				
16	Short Shaft - DO		B00-009-000	30	Shim (.002 & .006)	AS	B00-054-000				
17	Short Shaft - TO, GT		B00-009-100	31	Spacer	Reqd.					
18	Rotor - Twin Blade		B00-010-000	32	Fiber Washer	2	B00-055-000				
19	Lockwasher		B00-011-000	33	Bearing Retaining Plate	3	B00-055-100				
20	Wing Nut		B00-013-000	34	Hex Cap Screw	2	B00-080-000				
21	Oil Seal - B.H. Cover		B00-016-002	35	Rd. Hd. Cap Screw	6	B00-081-000				
22	Oil Seal - Front		B00-030-100		Truarc Ring	8	B00-083-000				
23						2	B00-087-R00				

See Vented Cover Section page 34 for Assembly Options and Part Breakdown



MODELS 25-DO, 25-TO AND 25-GT SEA

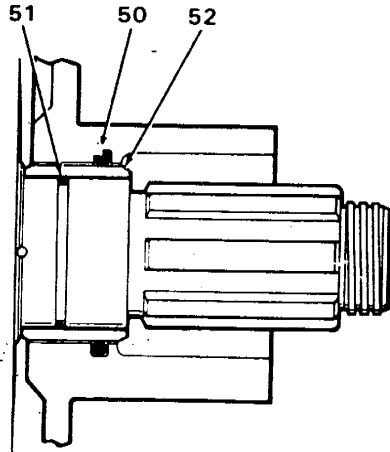

**MODEL DO "O" RING SEAL**

Item	Description	Qty	Part No.
50	"O" Ring - Body - Buna N	2	BDO-079-000
	"O" Ring - Body - Viton	2	BDO-079-V00
	"O" Ring - Body - Silicone	2	BDO-079-SC0
	"O" Ring - Body - E.P.	2	BDO-079-002
	U-Cup - Body - Buna N	2	BDO-079-U00
51	"O" Ring - Shaft - Buna N	2	BDO-097-000
	"O" Ring - Shaft - Viton	2	BDO-097-V00
	"O" Ring - Shaft - Silicone	2	BDO-097-SC0
52	Sleeve - Prong	2	BDO-098-001

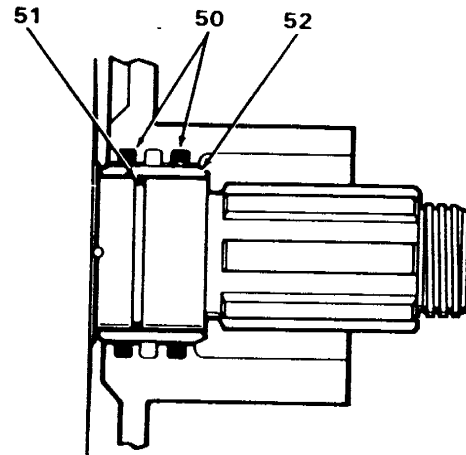

**MODEL TO "O" RING SEAL**

Item	Description	Qty	Part No.
50	"O" Ring - Body - Buna N	4	BDO-079-000
	"O" Ring - Body - Viton	4	BDO-079-V00
	"O" Ring - Body - Silicone	4	BDO-079-SC0
	"O" Ring - Body - E.P.	4	BDO-079-002
	U-Cup - Body - Buna N	4	BDO-079-U00
51	"O" Ring - Shaft - Buna N	2	BDO-097-000
	"O" Ring - Shaft - Viton	2	BDO-097-V00
	"O" Ring - Shaft - Silicone	2	BDO-097-SC0
52	Sleeve - Prong	2	BDO-098-T00

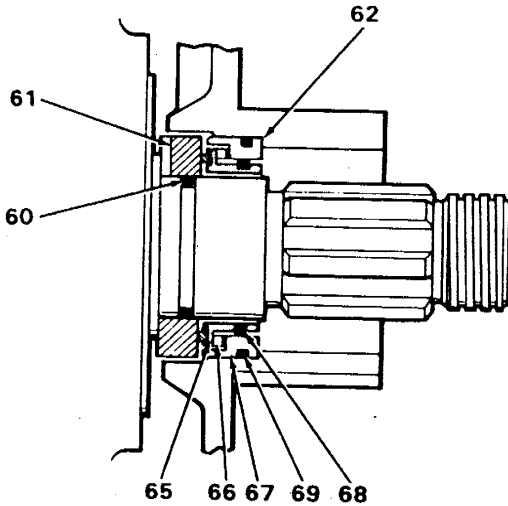

**MODEL GT MECHANICAL SEAL**

Item	Description	Qty	Part No.
60	"O" Ring - Shaft - Buna N	2	BDO-097-000
	"O" Ring - Shaft - Viton	2	BDO-097-V00
	"O" Ring - Shaft - Silicone	2	BDO-097-SC0
61	Seal Seat - Ceramic	2	BGT-014-000
62	Seal Case Assembly**	2	BGT-305-101
	Carbon Carrier Assembly**	2	BGT-306-101
	Ceramic Carrier Assembly**	2	BGT-306-111

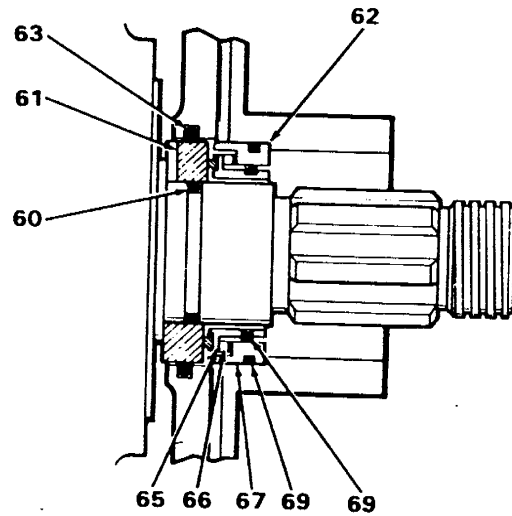

**MODEL GT MECHANICAL SEAL/B-B FLUSH**

Item	Description	Qty	Part No.
60	"O" Ring - Shaft - Buna N	2	BDO-097-000
	"O" Ring - Shaft - Viton	2	BDO-097-V00
	"O" Ring - Shaft - Silicone	2	BDO-097-SC0
61	Seal Seat - Ceramic	2	BGT-014-000
62	Seal Case Assembly	2	BGT-305-101
	Carbon Carrier Assembly	2	BGT-306-101
	Ceramic Carrier Assembly	2	BGT-306-111
63	"O" Ring - Buna	2	BGT-079-000
	"O" Ring - Viton	2	BGT-079-V00
	"O" Ring - E.P.	2	BGT-079-002

**\*\*Seal Assembly Breakdown**

65	Carrier - Carbon	2	BGT-306-000
	Carrier - Ceramic	2	BGT-306-010
66	Wave Spring	2	BGT-304-000
67	Seal Case	2	BGT-305-000

68	"O" Ring Carrier - Buna N	2	BGT-302-000
	"O" Ring Carrier - Viton	2	BGT-302-V00
69	"O" Ring Case - Buna N	2	BGT-303-000
	"O" Ring Case - Viton	2	BGT-303-V00



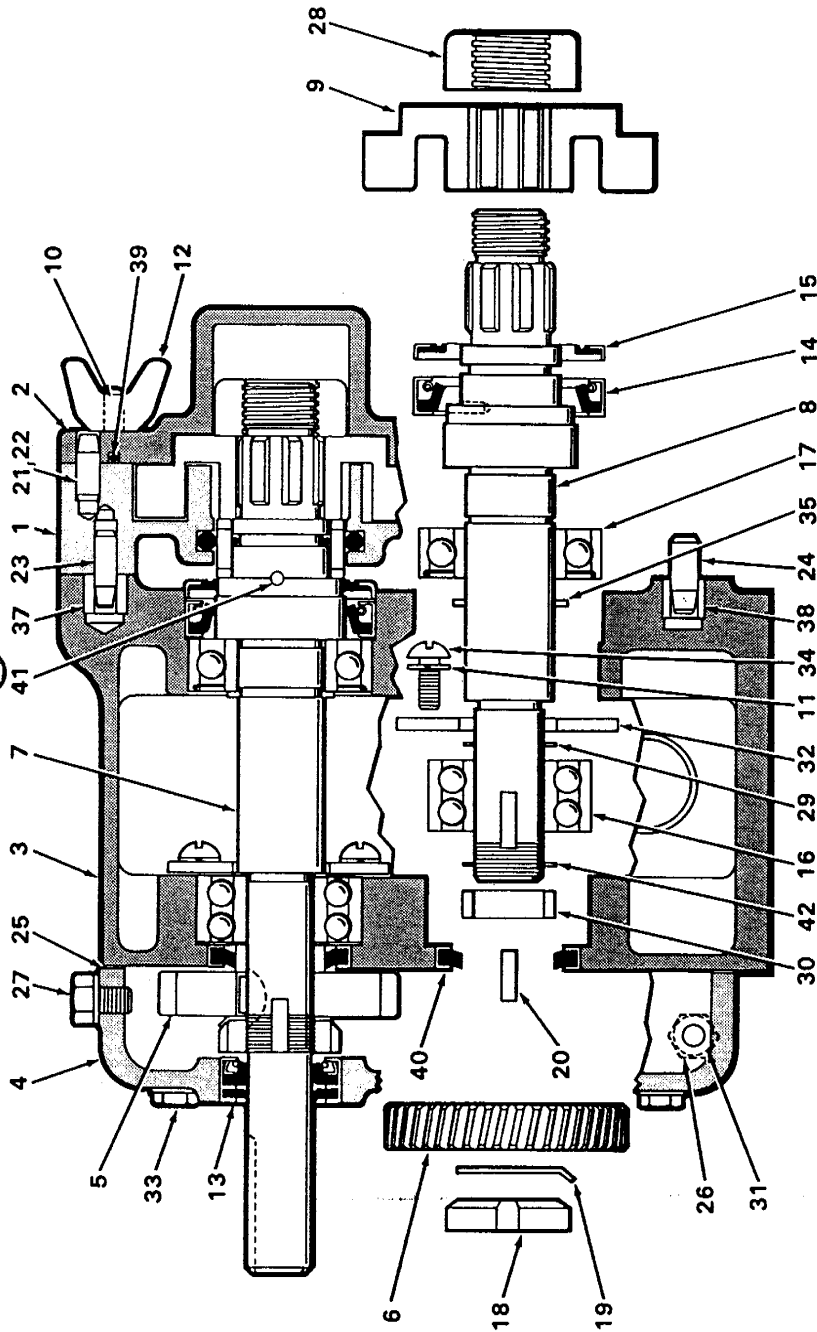

**MODELS 55-DO, 55-TO AND 55-GT**

Item	Description	Qty	Part No.	Item	Description	Qty	Part No.	Item	Description	Qty	Part No.
1	Body - DO	1	CDO-001-GSO	14	Oil Seal - Front	2	CDO-030-100	36	Grease Fitting	4	BDO-092-000
2	Body - TO	1	CDO-001-T00	15	Wiper Seal	2	CDO-030-1W0	37	Dowel Bush	1	CDO-116-000
3	Body - GT	1	CDO-001-GT0	16	Bearing - Rear	2	CDO-036-000	38	Dowel Bush	1	CDO-116-100
4	Cover - Vented*	1	055-002-V00	17	Bearing - Front	2	CDO-036-300	39	"O" Ring - Cover - Buna N	1	CDO-117-000
5	Cover - Jacketed	1	CDO-002-J10	18	Lock Nut - Gears	2	CDO-036-N00		"O" Ring - Cover - Viton	1	CDO-117-V00
6	Bearing Housing	1	CDO-105-SM0	19	Lockwasher - Gears	2	CDO-037-W00	40	Oil Seal - Rear	1	CDO-117-SG0
7	Bearing Housing - Side Mt.	1	CDO-105-SM0	20	Key - Gear	2	CDO-037-000	41	Drive Pin	2	CDO-119-000
8	Bearing Housing Cover - Upper	1	CDO-106-L00	21	Dowel Pin - Upper	1	CDO-040-000	42	Spacer Seal	2	CDO-126-000
9	Bearing Housing Cover - Lower	1	CDO-106-L00	22	Dowel Pin - Lower	1	CDO-040-100				
10	Bearing Housing Cover - Side Mt.	1	CDO-106-SM0	23	Dowel Pin Body - Upper	1	CDO-040-R00				
11	Drive Shaft - DO	1	CDO-007-H10	24	Dowel Pin Body - Lower	1	CDO-040-R10				
12	Drive Shaft - TO	1	CDO-007-H20	25	Gasket - B.H. Cover	1	CDO-042-SM0				
13	Drive Shaft - GT	1	CDO-008-T00	26	Gasket - B.H.C. - Side Mt.	1	CDO-046-000				
14	Short Shaft - DO	1	CDO-008-T00	27	Hex Cap Screw	2	CDO-046-100				
15	Short Shaft - TO	1	CDO-009-GT0	28	Breather Screw	2	B00-052-000				
16	Short Shaft - GT	1	CDO-009-GT0	29	Rotor Retaining Nut	2	CDO-054-000				
17	Short Shaft - DO	1	CDO-010-000		Shim (.002 & .006)	As					
18	Short Shaft - TO	1	CDO-009-GT0	30	Spacer	2	CDO-055-000				
19	Short Shaft - GT	1	CDO-010-000	31	Fiber Washer	3	ADO-064-000				
20	Rotor - Twin Blade	2	CDO-011-000	32	Bearing Retaining Plate	2	CDO-080-000				
21	Stud	8	CDO-013-000	33	Hex Cap Screw	6	CDO-081-000				
22	Lockwasher	6	CDO-016-002	34	Rd. Hd. Cap Screw	8	CDO-083-000				
23	Oil Seal - B.H. Cover	1	CDO-030-000	35	Truarc Ring	2	CDO-087-R00				
24											
25											
26											
27											
28											
29											
30											
31											
32											
33											
34											
35											
36											
37											
38											
39											
40											
41											
42											

\*See Vented Cover Section, page 34, for Assembly Options and Parts Breakdown.



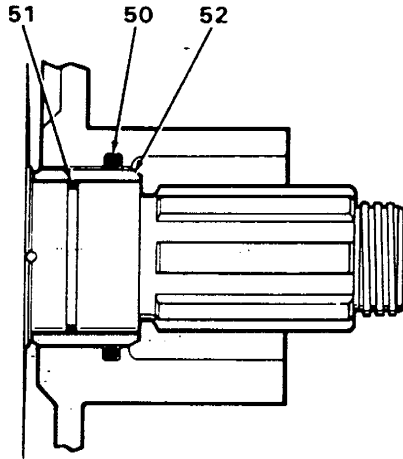

**MODEL DO "O" RING SEAL**

Item	Description	Qty	Part No.
50	"O" Ring - Body - Buna N	2	CDO-079-000
	"O" Ring - Body - Viton	2	CDO-079-V00
	"O" Ring - Body - Silicone	2	CDO-079-SC0
	"O" Ring - Body - E.P.	2	CDO-079-002
	U-Cup - Body - Buna N	2	CDO-079-U00
51	"O" Ring - Shaft - Buna N	2	CDO-097-000
	"O" Ring - Shaft - Viton	2	CDO-097-V00
	"O" Ring - Shaft - Silicone	2	CDO-097-SC0
52	Sleeve - Prong	2	CDO-098-001

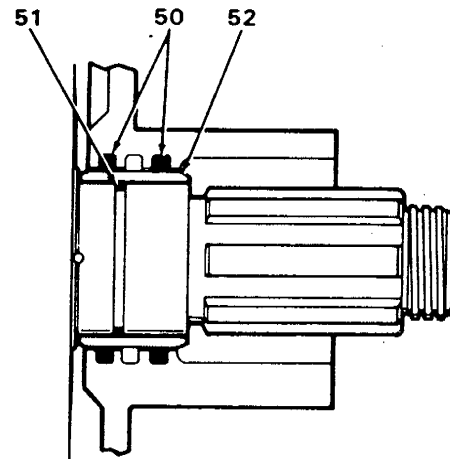

**MODEL TO "O" RING SEAL**

Item	Description	Qty	Part No.
50	"O" Ring - Body - Buna N	4	CDO-079-000
	"O" Ring - Body - Viton	4	CDO-079-V00
	"O" Ring - Body - Silicone	4	CDO-079-SC0
	"O" Ring - Body - E.P.	4	CDO-079-002
	U-Cup - Body - Buna N	4	CDO-079-U00
51	"O" Ring - Shaft - Buna N	2	CDO-097-000
	"O" Ring - Shaft - Viton	2	CDO-097-V00
	"O" Ring - Shaft - Silicone	2	CDO-097-SC0
	"O" Ring - Shaft - E.P.	2	CDO-097-002
52	Sleeve - Notched	2	CDO-098-T00

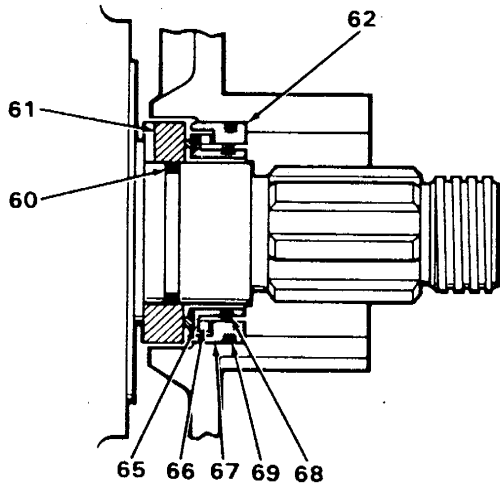

**MODEL GT MECHANICAL SEAL**

Item	Description	Qty	Part No.
60	"O" Ring - Shaft - Buna N	2	CDO-097-000
	"O" Ring - Shaft - Viton	2	CDO-097-V00
	"O" Ring - Shaft - Silicone	2	CDO-097-SC0
61	Seal Seat - Ceramic	2	CGT-014-000
62	Seal Case Assembly**	2	CGT-305-101
	Carbon Carrier Assembly**	2	CGT-306-101
	Ceramic Carrier Assembly**	2	CGT-306-111

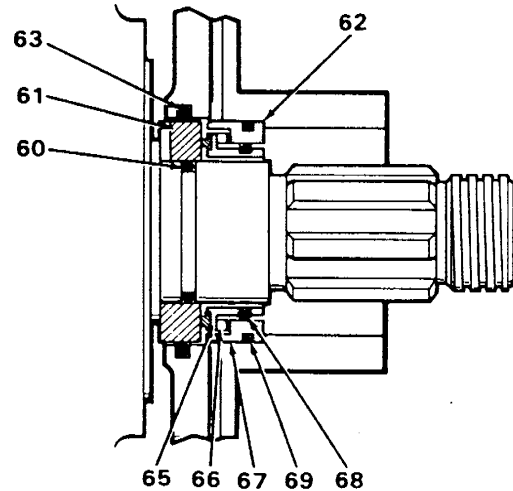

**MODEL GT MECHANICAL SEAL/BB FLUSH**

Use Body CDO-1-GTB			
Item	Description	Qty	Part No.
60	"O" Ring - Shaft - Buna N	2	CDO-097-000
	"O" Ring - Shaft - Viton	2	CDO-097-V00
	"O" Ring - Shaft - Silicone	2	CDO-097-SC0
61	Seal Seat - Ceramic	2	CGT-014-000
62	Seal Case Assembly	2	CGT-305-101
	Carbon Carrier Assembly	2	CGT-306-101
	Ceramic Carrier Assembly	2	CGT-306-111
63	"O" Ring - Buna	2	CGT-079-000
	"O" Ring - Viton	2	CGT-079-V00
	"O" Ring - E.P.	2	CGT-079-002

**\*\*Seal Assembly Breakdown**

65	Carrier - Carbon	2	CGT-306-000
	Carrier - Ceramic	2	CGT-306-010
66	Wave Spring	2	CGT-304-000
67	Seal Case	2	CGT-305-000

68	"O" Ring Carrier - Buna N	2	CGT-302-000
	"O" Ring Carrier - Viton	2	CGT-302-V00
69	"O" Ring Case - Buna N	2	CGT-303-000
	"O" Ring Case - Viton	2	CGT-303-V00

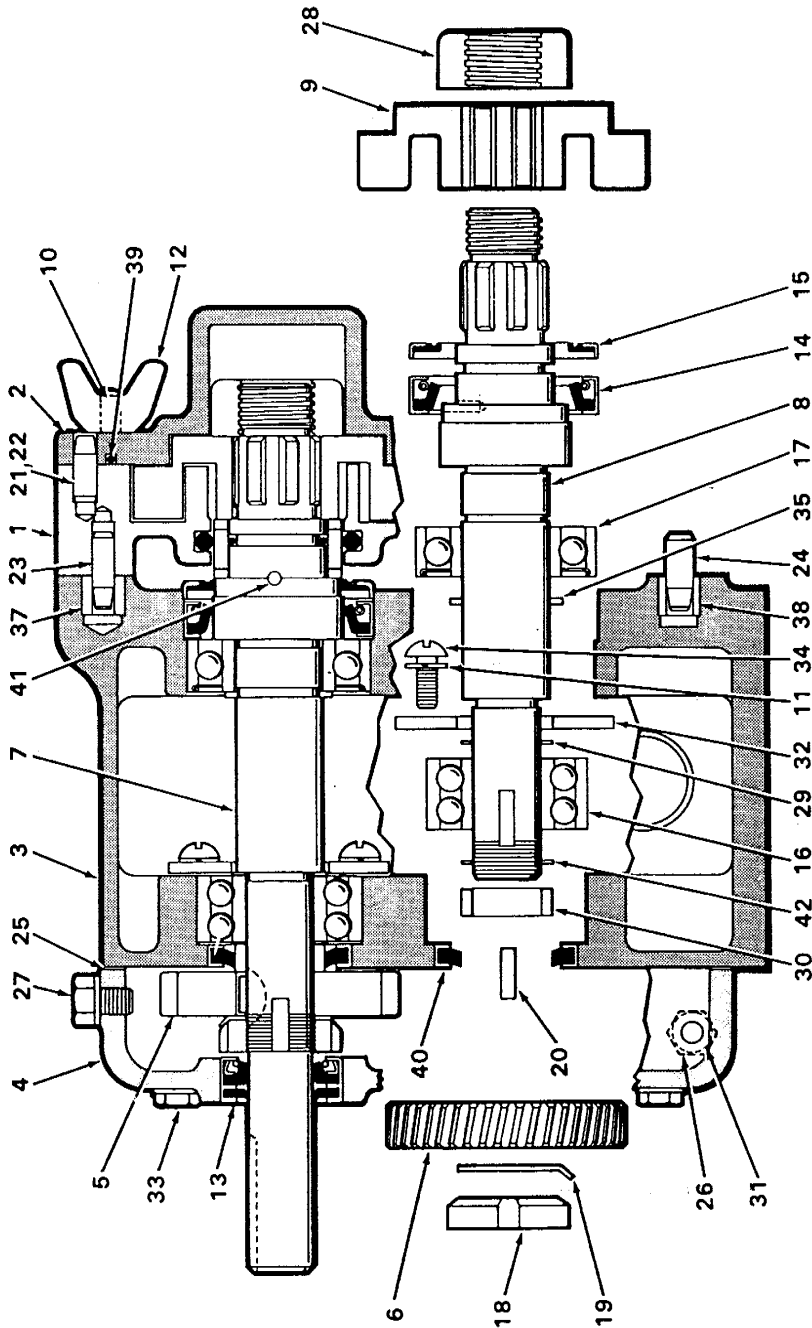

**MODEL 100-DO**

Item	Description	Qty	Part No.	Item	Description	Qty	Part No.	Item	Description	Qty	Part No.
1	Body - DO	1	D00-001-0S0	18	Lock Nut - Gears	2	C00-036-N00	38	Dowel Bush	1	C00-116-100
2	Cover	1	C00-002-0S0	19	Lockwasher - Gears	2	C00-036-W00	39	"O" Ring - Cover - Buna N	1	C00-117-000
3	Cover - Jacketed	1	055-002-V00	20	Key - Gear	2	C00-037-000		"O" Ring - Cover - Viton	1	C00-117-V00
4	Bearing Housing	1	C00-002-110	21	Dowel Pin - Upper	1	C00-040-000	40	"O" Ring - Cover - Silicone	1	C00-117-S00
5	Bearing Housing - Side Mt.	1	C00-105-000	22	Dowel Pin - Lower	1	C00-040-100	41	Oil Seal - Rear	2	C00-119-000
6	Bearing Housing Cover - Upper	1	C00-105-SM0	23	Dowel Pin - Body - Upper	1	C00-040-R00	42	Drive Pin	2	C00-126-000
7	Bearing Housing Cover - Lower	1	C00-106-000	24	Dowel Pin - Body - Lower	1	C00-040-R10		Spacer Seal	2	C00-127-000
8	Bearing Housing Cover - Side Mt.	1	C00-106-L00	25	Gasket - B.H. Cover	1	C00-042-SM0		OIL MICRO-PLATE #140		
9	Gear - Drive Shaft	1	C00-007-H10	26	Hex Cap Screw	2	C00-046-000		1 - Gallon Can		OBI-140-000
10	Gear - Short Shaft	1	C00-007-H20	27	Breather Screw	1	C00-046-100		1 - Quart Can		OBI-141-000
11	Drive Shaft - DO	1	D00-008-000	28	Rotor Retaining Nut	2	B00-052-000		GREASE MICRO-PLATE #2		OBI-142-000
12	Short Shaft - DO	1	D00-009-000	29	Shim (.002 & .006)	As Reqd.	C00-054-000		"O" Ring Removal Tool		ADO-096-001
13	Rotor - Twin Blade	2	D00-010-000	30	Spacer	2	C00-055-000		Rotor Nut Wrench		C00-019-000
14	Stud	8	D00-011-000	31	Fiber Washer	3	ADO-064-000				
15	Lockwasher	6	D00-013-000	32	Bearing Retaining Plate	3	C00-080-000				
16	Wing Nut	8	C00-016-002	33	Hex Cap Screw	6	C00-081-000				
17	Oil Seal - B.H. Cover	1	C00-030-000	34	Rd. Hd. Cap Screw	8	C00-083-000				
18	Oil Seal - Front	2	C00-030-1W0	35	Tuarc Ring	2	B00-092-000				
19	Wiper Seal	2	C00-036-000	36	Grease Fitting	4	C00-116-000				
20	Bearing - Rear	2	C00-036-000	37	Dowel Bush	1					
21	Bearing - Front	2	C00-036-300								

\*See Vented Cover Section, page 34, for Assembly Options and Parts Breakdown



**MODEL 100-DO SEAL**

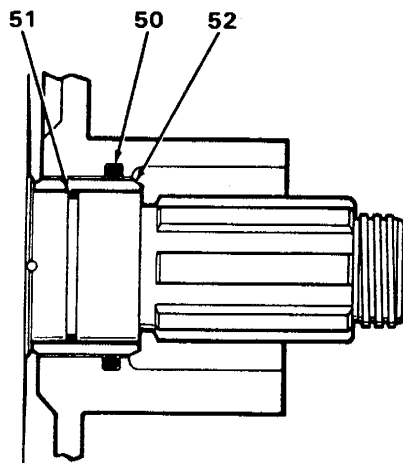

**MODEL DO "O" RING SEAL**

Item	Description	Qty	Part No.
50	"O" Ring - Body - Buna N	2	CDO-079-000
	"O" Ring - Body - Viton	2	CDO-079-V00
	"O" Ring - Body - Silicone	2	CDO-079-SC0
	"O" Ring - Body - E.P.	2	CDO-079-002
	U-Cup - Body - Buna N	2	CDO-079-U00
	51	"O" Ring - Shaft - Buna N	2
51	"O" Ring - Shaft - Viton	2	CDO-097-V00
	"O" Ring - Shaft - Silicone	2	CDO-097-SC0
	52	Sleeve - Prong	2

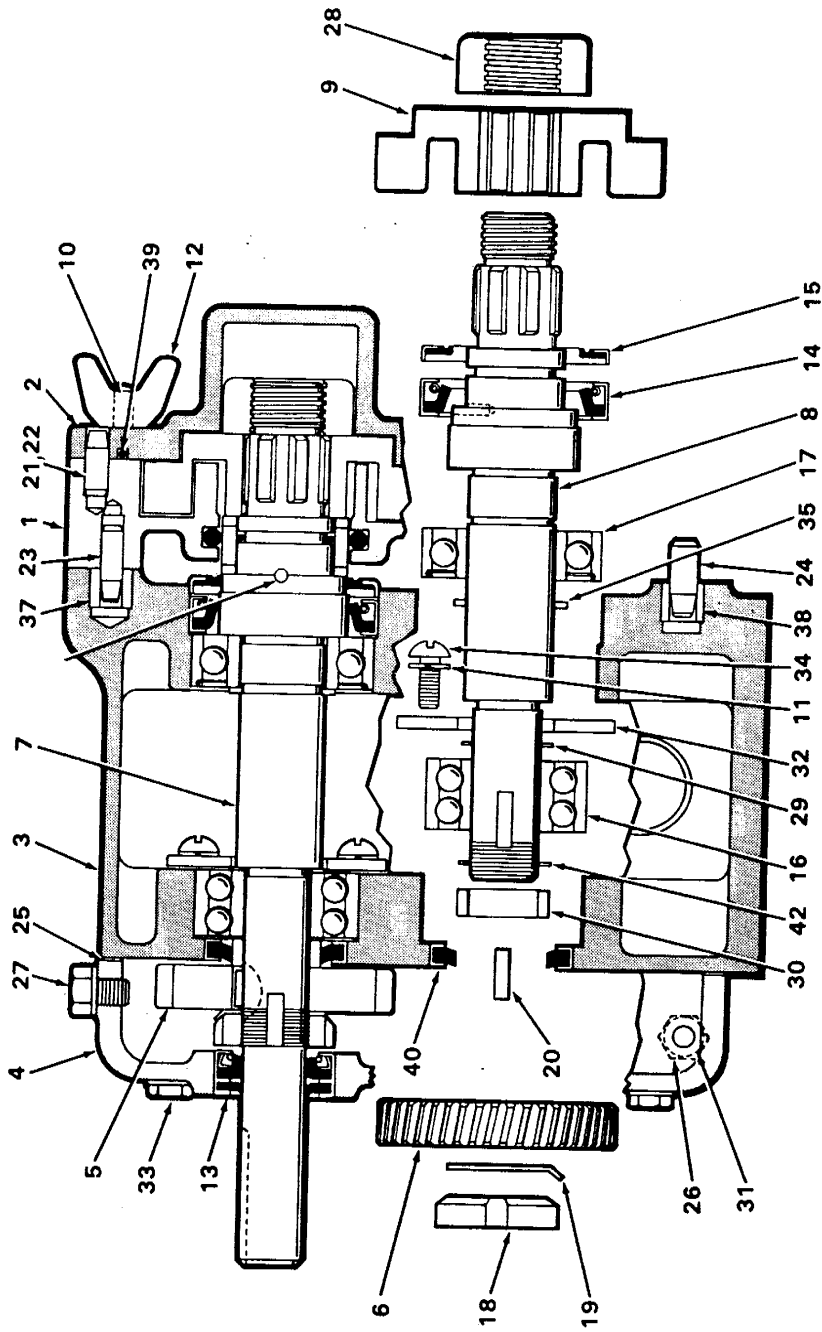

**MODELS 125-DO, 125-TO AND 125-GT**

Item	Description	Qty	Part No.	Item	Description	Qty	Part No.	Item	Description	Qty	Part No.
1	Body - DO	1	ED0-001-0S0	14	Oil Seal - Front	2	C00-030-100	136	Grease Fitting	4	B00-092-000
2	Body - TO	1	ED0-001-100	15	Wiper Seal	2	C00-030-1W0	37	Dowel Bush	1	C00-116-000
3	Body - GT	1	ED0-001-GT0	16	Bearing - Rear	2	C00-036-000	38	Dowel Bush	1	C00-116-100
4	Cover	1	C00-002-S00	17	Bearing - Front	2	C00-036-300	39	"O" Ring - Cover - Buna N	1	C00-117-000
5	Cover - Jacketed*	1	055-002-V00	18	Lock Nut - Gears	2	C00-036-R00	40	"O" Ring - Cover - Viton	1	C00-117-900
6	Cover - Jacketed	1	C00-002-J10	19	Lockwasher - Gears	2	C00-036-W00	41	"O" Ring - Cover - Silicone	1	C00-117-SC0
7	Bearing Housing - Side Mt.	1	C00-105-000	20	Key - Gear	2	C00-037-000	42	Oil Seal - Rear	2	C00-119-000
8	Bearing Housing - Upper	1	C00-105-SM0	21	Dowel Pin - Upper	1	C00-040-000		Spacer Seal	2	C00-126-000
9	Bearing Housing - Lower	1	C00-105-U00	22	Dowel Pin - Lower	1	C00-040-100		OIL MICRO-PLATE #140		
10	Bearing Housing - Side Mt.	1	C00-106-L00	23	Dowel Pin - Body - Upper	1	C00-040-R00		1 - Gallon Can		OBI-140-000
11	Bearing Housing - Cover - Side Mt.	1	C00-106-SM0	24	Dowel Pin - Body - Lower	1	C00-040-R10		1 - Quart Can		OBI-141-000
12	Gear - Drive Shaft	1	C00-007-H10	25	Gasket - B.H. Cover	1	C00-042-000		GREASE MICRO-PLATE #2		OBI-142-000
13	Gear - Short Shaft	1	C00-007-H20	26	Gasket - B.H.C. - Side Mt.	1	C00-042-SM0		1 - Pound Tube		
14	Drive Shaft - DO	1	ED0-008-000	27	Hex Cap Screw	2	C00-046-100		"O" Ring Removal Tool		ADO-096-001
15	Drive Shaft - TO	1	ED0-008-T00	28	Breather Screw	2	B00-052-000		Rotor Nut Wrench		C00-019-000
16	Drive Shaft - GT	1	ED0-008-GT0	29	Rotor Retaining Nut	As	C00-054-000		† Not Shown		
17	Short Shaft - DO	1	ED0-009-000	30	Shim (.002 & .006)	Reqd.			† See Vented Cover Section, page 34, for Assembly Options and Parts Breakdown.		
18	Short Shaft - TO	1	ED0-009-T00	31	Spacer	2	C00-055-000				
19	Short Shaft - GT	1	ED0-009-GT0	32	Fiber Washer	3	ADO-064-000				
20	Rotor - Twin Blade	2	ED0-010-000	33	Bearing Retaining Plate	2	C00-080-000				
21	Stud	8	ED0-011-000	34	Hex Cap Screw	6	C00-081-000				
22	Lockwasher	6	C00-013-000	35	Rd. Hd. Cap Screw	8	C00-083-000				
23	Wing Nut	8	C00-016-002		Triarc Ring	2	C00-087-R00				
24	Oil Seal - B.H. Cover	1	C00-030-000								

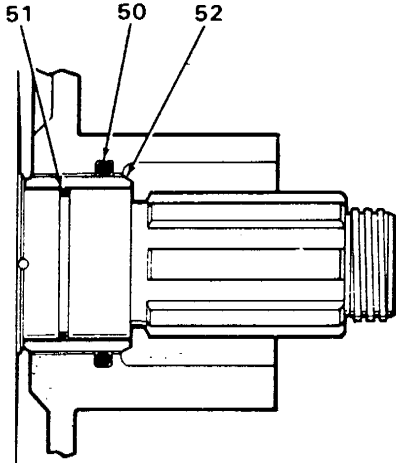

**MODEL DO "O" RING SEAL**

Item	Description	Qty	Part No.
50	"O" Ring - Body - Buna N	2	CDO-079-000
	"O" Ring - Body - Viton	2	CDO-079-V00
	"O" Ring - Body - Silicone	2	CDO-079-SC0
	"O" Ring - Body - E.P.	2	CDO-079-002
	U-Cup - Body - Buna N	2	CDO-079-U00
51	"O" Ring - Shaft - Buna N	2	CDO-097-000
	"O" Ring - Shaft - Viton	2	CDO-097-V00
	"O" Ring - Shaft - Silicone	2	CDO-097-SC0
52	Sleeve - Prong	2	CDO-098-001

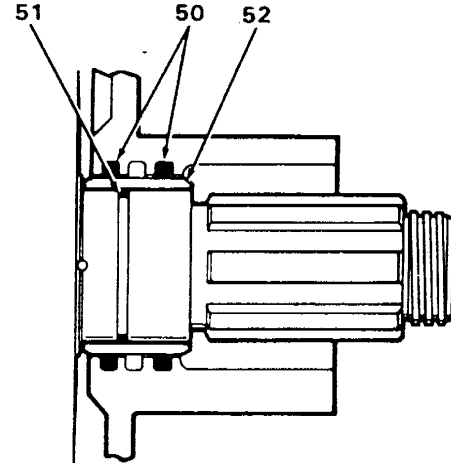

**MODEL TO "O" RING SEAL**

Item	Description	Qty	Part No.
50	"O" Ring - Body - Buna N	4	CDO-079-000
	"O" Ring - Body - Viton	4	CDO-079-V00
	"O" Ring - Body - Silicone	4	CDO-079-SC0
	"O" Ring - Body - E.P.	4	CDO-079-002
	U-Cup - Body - Buna N	4	CDO-079-U00
51	"O" Ring - Shaft - Buna N	2	CDO-097-000
	"O" Ring - Shaft - Viton	2	CDO-097-V00
	"O" Ring - Shaft - Silicone	2	CDO-097-SC0
52	Sleeve - Notched	2	CDO-098-T00

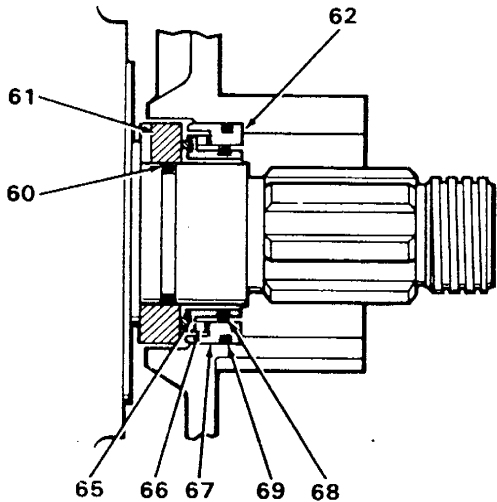

**MODEL GT MECHANICAL SEAL**

Item	Description	Qty	Part No.
60	"O" Ring - Shaft - Buna N	2	CDO-097-000
	"O" Ring - Shaft - Viton	2	CDO-097-V00
	"O" Ring - Shaft - Silicone	2	CDO-097-SC0
61	Seal Seat - Ceramic	2	CGT-014-000
62	Seal Case Assembly**	2	CGT-305-101
	Carbon Carrier Assembly**	2	CGT-306-101
	Ceramic Carrier Assembly	2	CGT-306-111

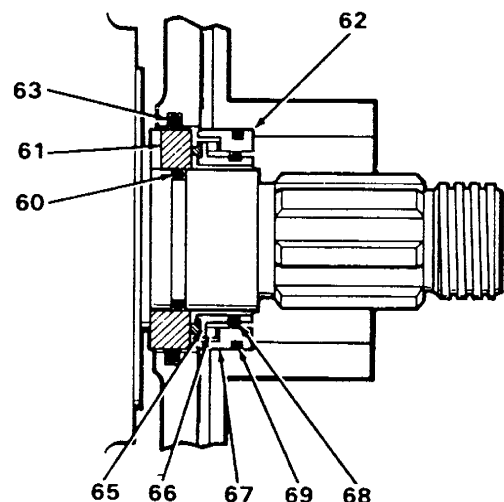

**MODEL GT MECHANICAL SEAL/B-B FLUSH**

Use Body EDO-1-GTB

Item	Description	Qty	Part No.
60	"O" Ring - Shaft - Buna N	2	CDO-097-000
	"O" Ring - Shaft - Viton	2	CDO-097-V00
	"O" Ring - Shaft - Silicone	2	CDO-097-SC0
61	Seal Seat - Ceramic	2	CGT-014-000
62	Seal Case Assembly**	2	CGT-305-101
	Carbon Carrier Assembly**	2	CGT-306-101
	Ceramic Carrier Assembly	2	CGT-306-111
63	"O" Ring - Buna	2	CGT-079-000
	"O" Ring - Viton	2	CGT-079-V00
	"O" Ring - E.P.	2	CGT-079-002

**\*\*Seal Assembly Breakdown**

65	Carrier - Carbon	2	CGT-306-000
	Carrier - Ceramic	2	CGT-306-010
66	Wave Spring	2	CGT-304-000
67	Seal Case	2	CGT-305-000

68	"O" Ring Carrier - Buna N	2	CGT-302-000
	"O" Ring Carrier - Viton	2	CGT-302-V00
69	"O" Ring Case - Buna N	2	CGT-303-000
	"O" Ring Case - Viton	2	CGT-303-V00

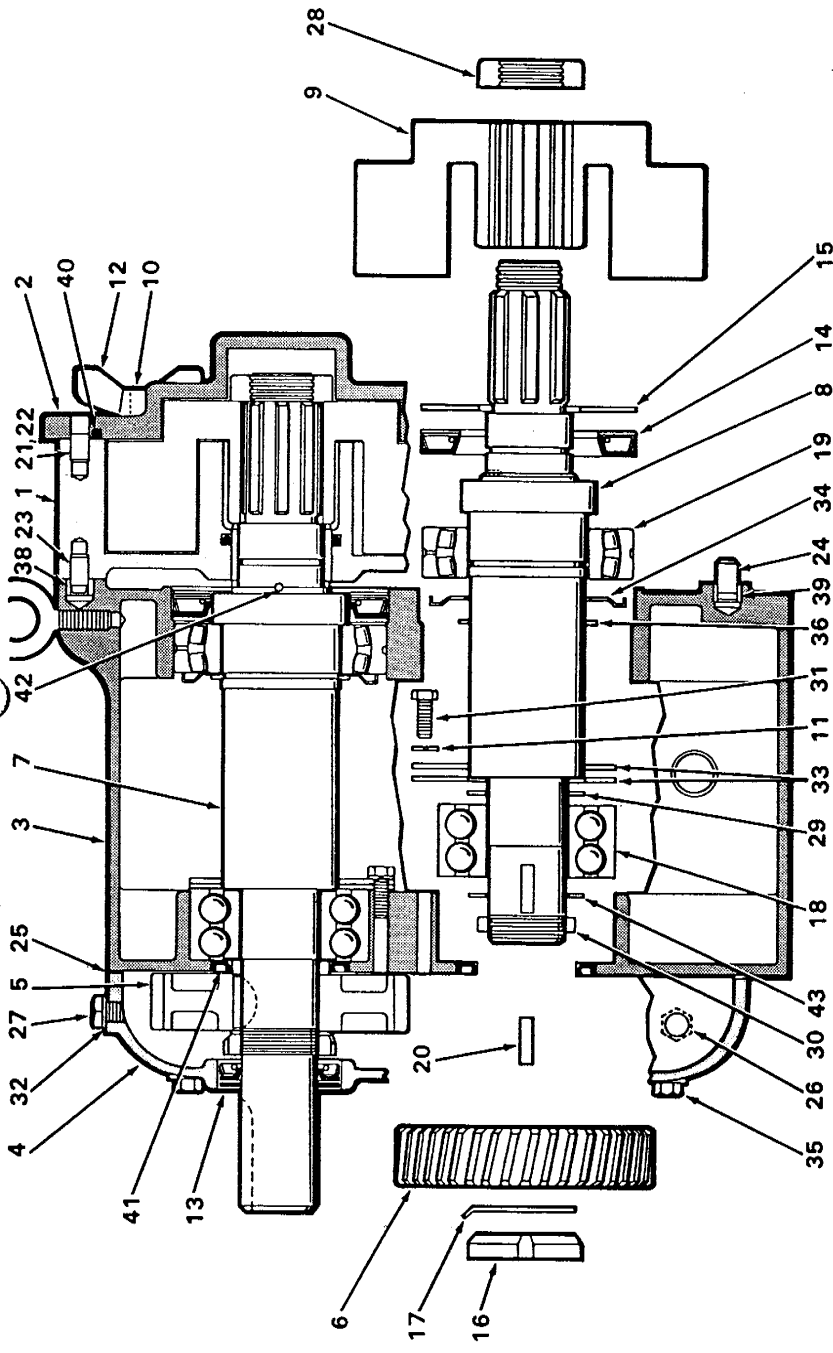

**MODELS 200-DO, 200-TO AND 200-GT**

Item	Description	Qty	Part No.	Item	Description	Qty	Part No.	Item	Description	Qty	Part No.
1	Body - DO	1	GDO-001-TSI	16	Lock Nut - Gear	2	GDO-036-N00	†37	Grease Fitting	4	B00-092-000
2	Body - TO	1	GDO-001-T0S	17	Lockwasher - Gear	2	GDO-036-W00	38	Dowel Bushing	1	C00-116-000
3	Body - GT	1	GDO-001-GTO	18	Bearing - Rear	2	GDO-036-000	39	"O" Ring - Cover - Buna	1	G00-116-100
4	Cover - Vented*	1	GDO-002-S00	19	Bearing - Front	2	GDO-036-300	40	"O" Ring - Cover - Viton	1	G00-117-000
5	Bearing Housing - Side Mt.	1	210-002-V10	20	Key - Gear	2	GDO-037-000	41	"O" Ring - Cover - Silicone	1	G00-117-S00
6	Bearing Housing - Cover - U	1	GDO-105-SM0	21	Dowel Pin - Upper	1	GDO-040-000	42	Seal - B.H. - Rear	2	G00-119-000
7	Bearing Housing - Cover - L	1	GDO-106-SM0	22	Dowel Pin - Lower	1	GDO-040-100	43	Spacer Seal	2	G00-126-000
8	Bearing Housing - Cover - SM	1	GDO-106-L00	23	Dowel Pin	1	GDO-040-R00				
9	Gear - Drive Shaft	1	GDO-106-SM0	24	Dowel Pin	1	C00-040-R10				
10	Gear - Short Shaft	1	GDO-007-H10	25	Gasket - B.H. - Cover	1	GDO-042-000				
11	Drive Shaft - DO & TO	1	GDO-007-H20	26	Gasket - B.H. - Cover	1	GDO-042-SM0				
12	Drive Shaft - GT	1	GDO-008-T00	27	Hex Cap Screw - Vented	2	C00-046-000				
13	Short Shaft - DO & TO	1	GDO-008-GT0	28	Rotor Nut	2	GDO-052-000				
14	Short Shaft - GT	1	GDO-009-GT0	29	Shim (.002 & .006)	As Req'd.	GDO-054-000				
15	Studs	2	GDO-010-000	30	Spacer	2	GDO-055-000				
16	Lockwasher	6	GDO-011-000	31	Hex Cap Screw	6	B8B-058-000				
17	Wing Nut	6	GDO-013-000	32	Fiber Washer	2	AD0-064-000				
18	Seal - Gear Cover	8	GDO-016-002	33	Bearing Retainer Plate	4	GDO-080-000				
19	Seal - Bearing Housing Front	2	GDO-030-000	34	Bearing Seal	4	GDO-080-200				
20	Seal - Wiper	1	GDO-030-100	35	Hex Cap Screw	6	GDO-081-000				
21		2	GDO-030-1W0	36	Ext. Truarc Ring	2	GDO-087-000				
22				37							
23				38							
24				39							
25				40							
26				41							
27				42							
28				43							
29											
30											
31											
32											
33											
34											
35											
36											
37											
38											
39											
40											
41											
42											
43											

\*See Vented Cover Section, page 34, for Assembly Options and Parts Breakdown.





**MODELS 200-DO, 200-TO AND 200-GT SEALS**

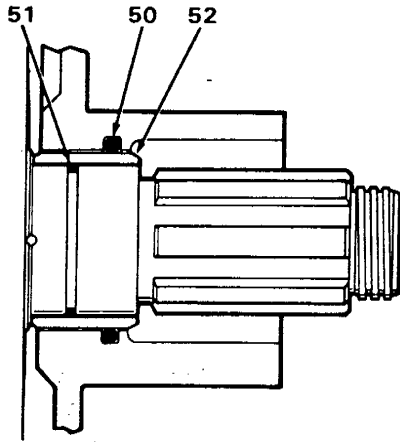

**MODEL DO "O" RING SEAL**

Item	Description	Qty	Part No.
50	"O" Ring - Body - Buna	2	GDO-079-000
	"O" Ring - Body - Viton	2	GDO-079-V00
	"O" Ring - Body - Silicone	2	GDO-079-SC0
	"O" Ring - Body - E.P.	2	GDO-079-002
	U-Cup - Body - Buna N	2	GDO-079-U00
51	"O" Ring - Shaft - Buna N	2	GDO-097-000
	"O" Ring - Shaft - Viton	2	GDO-097-V00
	"O" Ring - Shaft - Silicone	2	GDO-097-SC0
52	Sleeve - Prong Type	2	GDO-098-T01

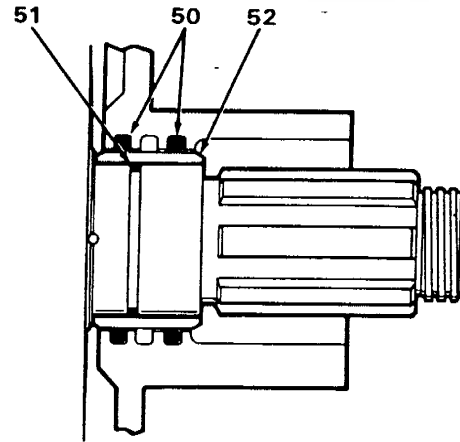

**MODEL TO DOUBLE "O" RING SEAL**

Item	Description	Qty	Part No.
50	"O" Ring - Body - Buna	4	GDO-079-000
	"O" Ring - Body - Viton	4	GDO-079-V00
	"O" Ring - Body - Silicone	4	GDO-079-SC0
	"O" Ring - Body - E.P.	4	GDO-079-002
	U-Cup - Body - Buna N	4	GDO-079-U00
51	"O" Ring - Shaft - Buna N	2	GDO-097-000
	"O" Ring - Shaft - Viton	2	GDO-097-V00
	"O" Ring - Shaft - Silicone	2	GDO-097-SC0
52	Sleeve - Prong Type	2	GDO-098-T01

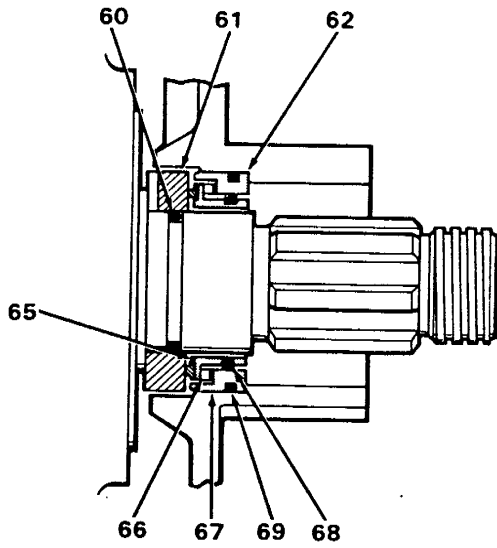

**MODEL GT MECHANICAL SEAL**

Item	Description	Qty	Part No.
60	"O" Ring - Shaft - Buna N	2	GDO-097-000
	"O" Ring - Shaft - Silicone	2	GDO-097-SC0
	"O" Ring - Shaft - Viton	2	GDO-097-V00
61	Seal Seat - Ceramic	2	GGT-014-000
62	Seal Case Assembly**	2	GGT-305-101
	Carbon Carrier Assembly**	2	GGT-306-101
	Ceramic Carrier Assembly**	2	GGT-306-111

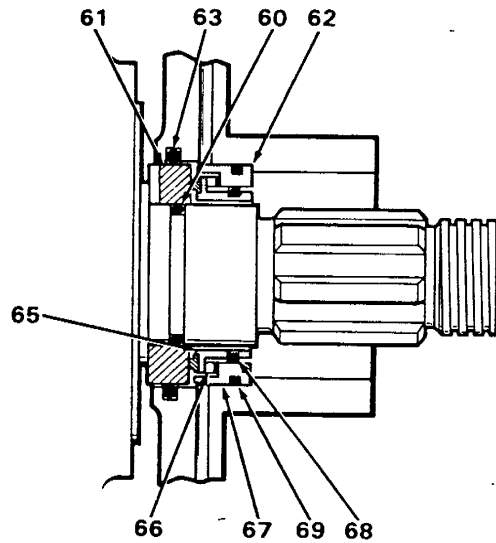

**MODEL GT MECHANICAL SEAL/B-B FLUSH**

Item	Description	Qty	Part No.
60	"O" Ring - Shaft - Buna N	2	GDO-097-000
	"O" Ring - Shaft - Silicone	2	GDO-097-SC0
	"O" Ring - Shaft - Viton	2	GDO-097-V00
61	Seal Seat - Ceramic	2	GGT-014-000
62	Seal Case Assembly**	2	GGT-305-101
	Carbon Carrier Assembly**	2	GGT-306-101
	Ceramic Carrier Assembly**	2	GGT-306-111
63	"O" Ring - Body - Buna	2	GGT-079-000
	"O" Ring - Body - Viton	2	GGT-079-V00
	"O" Ring - Body - E.P.	2	GGT-079-002

**\*\*Seal Assembly Breakdown**

65	Carrier with Carbon	2	GGT-306-000
	Carrier with Ceramic	2	GGT-306-010
66	Wave Spring	2	GGT-304-000
67	Seal Case	2	GGT-305-000

68	"O" Ring Carrier - Buna N	2	GGT-302-000
	"O" Ring Carrier - Viton A	2	GGT-302-A00
69	"O" Ring - Case - Buna N	2	GGT-303-000
	"O" Ring - Case - Viton A	2	EDO-133-V00



611 SUGAR CREEK ROAD  
DELAVAN, WI 53115 U.S.A.  
CUSTOMER SERVICE TELEPHONE  
1-800-252-5200 OR 262-728-1900  
TOLL FREE TELEFAX  
1-800-252-5012 OR 262-728-4904