



ITT

Engineered Valves

Pure-Flo[®] Bypass

(BP)

Typical Bioprocessing and Pharmaceutical processes utilize large quantities of water. Processes such as WFI storage, Media hold and Buffer preparation utilize large vessels for holding or preparing the process fluids. The Bypass valve is specifically designed to optimize the fill rate of these large vessels. By utilizing two different flow paths the process can be filled quickly with the larger valve and filled at a slower rate by the smaller valve for topping off the process, saving significant time in the process.

Typical Applications

- Tank filling applications

Specifications

Standard Sizes:

- 0.5" - 2" (DN 15 - 50) Valve size
- 0.25" (DN 8) .18 I.D. Bypass size (.18" I.D.)
- Other sizes available upon request

Materials:

- 316L ASTM - A479
- DN 177440, 1.4435
- AL6XN
- Hasteloy C-22 & C-276
- Other materials available upon request

Standard End Connections:

- 14, 16, 18, 20 Gauge OD tubing
- DIN/ISO
- Tri-Clover Tri-Clamp[®]
- Others available upon request

Compatible with standard Pure-Flo topworks: See PFTOP for details on available manual bonnets or actuator.

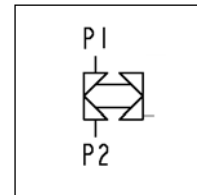

Flow Path

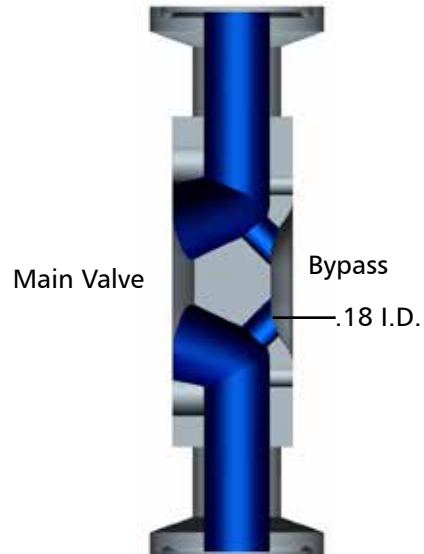

How to Order a Bypass Valve

.5" wrought stainless steel valve with Bio-Pure Bypass valve, Tri-Clamp ends, 25 Ra interior finish, standard exterior finish (Scotch Brite).

Figure Number: BP-1-419-.25-SVBP-W-6-1-0

Configuration Example		BP	.5	419	.25	SVBP	W	6-1-0
Valve Body	Block Type	BP						
	Valve Size ¹		.5					
	Body End Connections (P1, P2)			419				
	Second Valve Size ²				.25			
	Second Valve Type					SVBP		
	Body Material						W	
	Polish Selections							6-1-0

¹ Available in .5" - 3" valve sizes. Bypass valves will always be wrought body now.

² 1/4" standard bypass valve size (internal passage diameter .18"). Consult the factory for additional bypass valve sizes.

To add topworks, see BBTOP. For additional figure numbers, see PFORD.

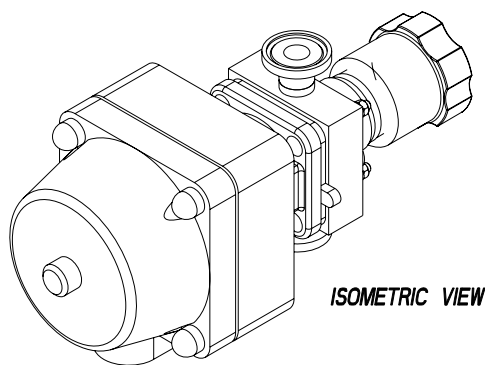

Please contact ITT Engineered Valves for the latest drawing and dimensional information. The above drawing should only be used as a general reference.

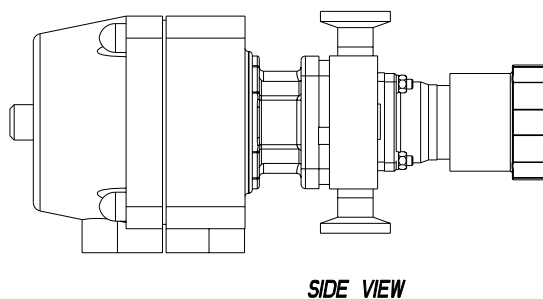
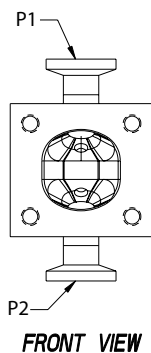

ITT Engineered Valves
33 Centerville Road
Lancaster, PA 17603, USA
Tel: +1 (717) 509-2200

Cam-Line, Cam-Tite, Dia-Flo,
EnviZion, Pure-Flo, Skotch

ITT Engineered Valves
1110 Bankhead Avenue
Amory, MS 38821, USA
Tel: +1 (662) 256-7185

Fabri-Valve

ITT Bornemann GmbH
31683 Obernkirchen
Germany
Tel: +49 5724 390-0

EnviZion, Pure-Flo