



# Pure-Flo<sup>®</sup> & EnviZion<sup>®</sup>

Ordering Guide



**ITT**

# Ordering Guide

This brochure contains a comprehensive list of the figure number codes and description for each valve product option available for the standard Pure-Flo and EnviZion products. To assist in the ordering process, we have included instructions on how to construct a standard valve figure number in proper sequence. ITT's channel partners can also find our e-Prism tool available at [www.engvalves.com/Members/e-Prism/](http://www.engvalves.com/Members/e-Prism/). This tool is a simple means of identifying valve product configuration and nomenclature. This tool will assist in selecting compatible features and proper designation structure.

## TABLE of CONTENTS

### Standard Pure-Flo Valve Figure Codes

Valve Size .....	3
Bodies & Polishes .....	4-5
Diaphragms .....	5
Bonnets & Bonnet Options .....	6
Actuator Options .....	7
Switches & Actuator Accessories .....	8-9
Service Preparation & Quality Documents .....	10
Obsolete Figure Codes .....	11
Block Body Figure Codes .....	12-38

### EnviZion Valve Figure Codes

EnviZion Valves .....	40-43
-----------------------	-------

# Pure-Flo Ordering Guide

## Pure-Flo Valve Figure Numbers

### How to Construct a Standard Valve Figure Number

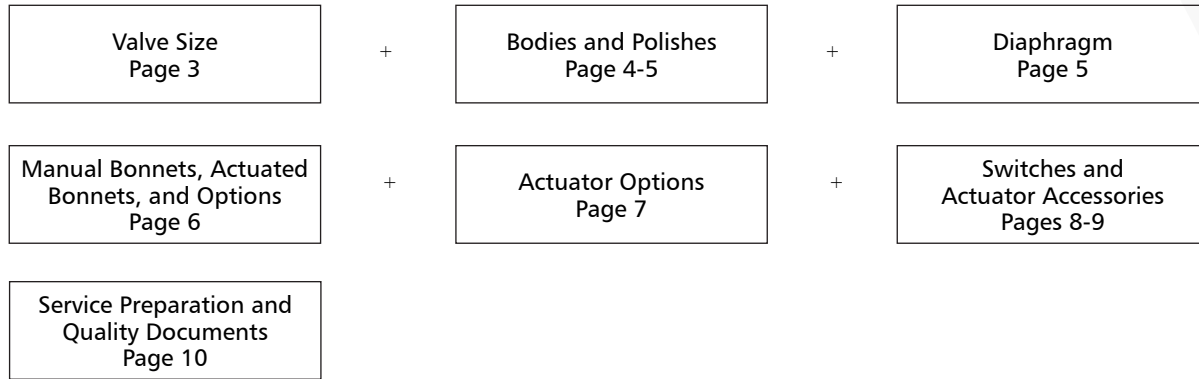

### Constructing Figure Numbers

Below are examples for constructing a manual and actuated valve figure number. The actuated valve example will be used to build a figure number on pages 3-10.

#### Manual Valve Example

**Figure Number:** 1-F-419-6-0-0-TME-963

Detailed description:

- 1: 1 inch size (DN25)
- F: Forged 316L SS
- 419: Triclamp Tube
- 6: Interior Finish: Ra 25 Microinch Max
- 0: Exterior Finish: No Mechanical Polish
- 0: No Electropolish
- TME: Modified PTFE Diaphragm (FDA)/ Grade B1 B.C.
- 963: Plastic PAS Rising Handwheel with Travel Stop

#### Actuated Valve Example

**Figure Number:** 1-F-428L-6-0-0-TME-B209-ISP-3W-HZ

Detailed description:

- 1: 1 inch size (DN25)
- F: Forged 316L SS
- 428L: 16 Gauge Extended Tangent Butt weld
- 6: Interior Finish: Ra 25 Microinch Max
- 0: Exterior Finish: No Mechanical Polish
- 0: No Electropolish
- TME: Modified PTFE Diaphragm (FDA)/ Grade B1 B.C.
- B209: Advantage 2.1 Actuator, Fail Close, 0.75" or 1" with a 90# Spring
- ISP: 3W - 3 Wire Output
- ISP: NSV - No Solenoid
- ISP: ST - Standard Cover
- ISP: NBT - No Diagnostics
- ISP: HZ - Hazardous Location Class I, II, III; DIV 2

### Valve Size

#### Size

Code	Description
.25	.25 Inch (DN6)
.38	.38 Inch (DN10)
.50	.50 Inch (DN15)
.75	.75 Inch (DN20)
1	1 Inch (DN25)
1.25	1.25 Inch (DN32)
1.5	1.5 Inch (DN40)
2	2 Inch (DN50)
2.5	2.5 Inch (DN65)
3	3 Inch (DN80)
4	4 Inch (DN100)
6	6 Inch (DN150)

**Figure Number:** 1

Configuration Example	1
Valve Size	1

# Bodies and Polishes

## Body Type

Code	Description
2	Industrial Valve Body - Cast CF3M Stainless Steel
8	Bio-Tek® Forged 316L Stn. Stl.
BP	Bio-Pure® Forged 316L Stn. Stl.
C	Cast CF3M Stainless Steel
F	Forged 316L Stainless Steel
N	Body Not Supplied
S	Swickle Body Cast CF3M Stn. Stl.
TBV	Tank Bottom Valve
TBVCR	Tank Bottom Valve 316L BN2
W	Wrought 316L Stainless Steel
Spec	Special Material Body

## Body Ends

Code	Description
<b>Clamp</b>	
409	Swagelok TS Fitting
410	Tri-Clamp Sch. 5 Pipe
414	I Line-Male
415	I Line-Female
416	Swivel Nut
418	ISO 1.6mm Wall Tri-Clamp End
419	Tri-Clamp Tube
419S	Tri-Clamp Tube 18 Gauge
419S1	Tri-Clamp Tube 20 Gauge
<b>Buttweld</b>	
422	Sch. 5 Pipe (ISO Body)
423	18 Gauge
424	20 Gauge
425	Sch. 5 Pipe (ANSI Body)
426	Sch. 10 Pipe
427	Sch. 40 Pipe
428	16 Gauge
428L	16 Gauge Ext. Tangent BW
429	14 Gauge
429L	14 Gauge Ext. Tangent BW
430	12 Gauge BW
433	ANSI Flanged

## Body Ends (cont.)

Code	Description
481	DIN Series 1
482	DIN Series 2
483	DIN Series 3
484	SMS
485	TBV, 45 Degree 14 GA BW
486	TBV, 45 Degree 16 GA BW
487	TBV, 45 Degree 18 GA BW
488	TBV, 45 Degree Tri-Clamp
493	ISO 2.9mm wall
494	ISO 1.2mm wall
495	ISO 1.0mm wall
496	ISO 1.6mm wall
497	ISO 2.0mm wall
498	ISO 2.3mm wall
499	ISO 2.6mm wall
Spec	Special End
<b>Screwed</b>	
403	NPT Screwed
<b>FLANGED</b>	
433R	ANSI Flanged w/ Raised Face

## Second End Code

Code	Description
<b>Clamp</b>	
X07	By Male Thread w/ Gasket Seat
X09	Swagelok TS Fitting
X10	By Tri-Clamp Sch. 5 Pipe
X14	By I Line - Male
X15	By I line - Female
X19	By Tri-Clamp Tube
X19S	By Tri-Clamp Tube 18 Gauge
X19S1	By Tri-Clamp Tube 20 Gauge
<b>Buttweld</b>	
X22	By Sch. 5 Pipe (ISO Body)
X23	By 18 Gauge
X24	By 20 Gauge
X25	By Sch. 5 Pipe (ANSI Body)
X26	By Sch. 10 Pipe
X27	By Sch. 40 Pipe
X28	By 16 Gauge
X28L	By 16 Gauge Ext. Tangent BW
X29	By 14 Gauge

## Second End Code (cont.)

Code	Description
X29L	By 14 Gauge Ext. Tangent BW
X30	By 12 Gauge BW
X81	By DIN Series 1
X82	By DIN Series 2
X83	By DIN Series 3
X84	By SMS
X85	By ISO
X93	By ISO 2.9mm Wall
X94	By ISO 1.2mm Wall
X95	By ISO 1.0mm Wall
X96	By ISO 1.6mm Wall
X97	By ISO 2.0mm Wall
X98	By ISO 2.3mm Wall
X99	By ISO 2.6mm Wall
Spec	Special End

## Tube Extension

Code	Description
TE1	Valve End 1
TE2	Valve End 2
TEA	Both Valve Ends & Purge End
TEB	Both Valve Ends
TEP	Purge End
TE1P	Valve End (P1) & Purge (P3)
TE2P	Valve End (P2) & Purge (P3)

## Mechanical Polish - Interior

Code	Description
0	No Mechanical Polish
2	35 $\mu$ in Ra (.8 $\mu$ m) max
6	25 $\mu$ in Ra (.6 $\mu$ m) max
7	15 $\mu$ in Ra (.38 $\mu$ m) max
8	20 $\mu$ in Ra (.5 $\mu$ m) max
9	11 $\mu$ in Ra (.28 $\mu$ m) max
10	10 $\mu$ in Ra (.25 $\mu$ m) max
SF1	BPE SF1 Ra 20 Max
SF2	BPE SF2 Ra 25 Max
SF3	BPE SF3 Ra 30 Max
SF4	BPE SF4 Ra 15 Max, EP
SF5	BPE SF5 Ra 20 Max, EP
SF6	BPE SF6 Ra 25 Max, EP

Figure Number: 1-F-428L-6-0-0-

		Configuration Example	F	428L		6	0	0
Bodies and Polishes	Block Type		F					
	Body Ends			428L				
	Second End Code							
	Tube Extension							
	Mechanical Polish - Interior					6		
	Mechanical Polish - Exterior						0	
	Electropolish							0
	Body Only							

# Body and Polishes / Diaphragms

## Mechanical Polish - Exterior

Code	Description
0	No Mechanical Polish
1	Scotch Brite
2	25 $\mu$ in Ra (.6 $\mu$ m) max, Welds Scotch Brite
3	35 $\mu$ in Ra (.8 $\mu$ m) max, Welds Scotch Brite
4	25 $\mu$ in Ra (.6 $\mu$ m) max, Welds Removed
6	35 $\mu$ in Ra (.8 $\mu$ m) max, Welds Removed
7	Special Polish Requirement
8	No Ext Body Polish, Weld Beads Removed

## Electropolish

Code	Description
0	No Electropolish
2	Exterior Only
3	Interior and Exterior
4	Interior Only

## Body Only

Code	Description
Y	Body Only Supplied

## Diaphragms

Code	Description
B	Black Butyl (FDA)
E1	EPDM Grade E1 (FDA)
EN	Elastomer Not Supplied
M	EPDM (non-FDA)
P	BUNA - N (FDA)
PN	PTFE Not Supplied
TME	PTFE Grade TM, Grade B1 backing cushion (FDA)
V	Viton
W1	White Butyl (FDA)

Figure Number: 1 -F-428L-6-0-0-TME-

Configuration Example	TME
Diaphragm	TME

# Manual Bonnets, Actuator Bonnets and Options

## Manual Bonnets

Code	Description
<b>Bio-Tek</b>	
18	Standard Bonnet, Non-Sealed
18S	Standard Bonnet, Sealed
<b>Bio-Pure</b>	
BPM	Standard Bonnet, Non-Sealed
BPMC	Standard Bonnet, Sealed (COP)
<b>Cast Iron</b>	
903	Rising Stem with Travel Stop
903S	Rising Stem with Travel Stop - Sealed
<b>Stainless Steel (316)</b>	
913	Rising Stem with Travel Stop
913S	Rising Stem with Travel Stop - Sealed
915	CH WHL with Travel Stop
915S	CH WHL with Travel Stop - Sealed
970	Rising Handwheel with Travel Stop
<b>Plastic PAS*</b>	
963	Rising Handwheel with Travel Stop (1/2" - 4")
963S	Rising Handwheel with Travel Stop - Sealed (1/2" - 4")

\*NA-2.5" Casting

## Actuated Bonnets

Code	Description
<b>Cast Iron</b>	
40	Direct Load
<b>Stainless Steel</b>	
31	Actuated
31S	Actuated - Sealed
<b>Ductile Iron</b>	
34	Actuated
34S	Actuated - Sealed
84	Dualrange
84S	Dualrange Sealed
<b>Plastic PAS*</b>	
36	Actuated
36S	Actuated - Sealed

\*NA-2.5" Casting

Figure Number: 1-F-428L-6-0-0-TME-31-

Configuration Example		31							
Manual Bonnets & Accessories	Manual Bonnets								
	Actuated Bonnets								
	Weep Holes								
	Electropolish Topworks								
	Optional Coatings								
	Bonnet Seal Materials								
	Optional Bonnet Internals <sup>1</sup>								
	Optional Body/Bonnet Bolting								
	Yoke								
	Locking Device								
	Extended Stem								

<sup>1</sup>Multiple selections allowed

## Weep Holes

Code	Description
W2	Two Weep Holes in Bonnet
W4	Four Weep Holes in Bonnet

## Electropolish Topworks

Code	Description
1	Topworks

## Optional Coatings

Code	Description
C1	PVDF Coated Topworks
C4	White Epoxy Coated Topworks
C7	Nylon Coated Topworks
CSpec	Coating Specified

## Bonnet Seal Materials

Code	Description
S1	EPDM
S2	Viton

## Optional Bonnet Internals

Code	Description
M5	Stainless Steel Stem
M6	Cast Iron Compressor
M7	Bronze Compressor
M8	PVDF Coated Cast Iron Compressor
M9	Stainless Steel Bushing
M10	Stainless Steel Tube Nut
M17	PPS Cap
M18	Heat Shrink Tubing on Handwheel

## Optional Body/Bonnet Bolting

Code	Description
B8	Stainless Steel ASTM A193 B8
BLTS	MNT HDWR, Except STDS, Supplied w/o Body
BSpec	Special Bonnet Flange Bolting
MET	Metric Bonnet Flange Fasteners

## Yoke

Code	Description
Y	Yoke Supplied

## Locking Device

Code	Description
LD	Locking Device

## Extended Stem

Code	Description
EXTSTEM	Extended Stem
EXTSTEMR	Extended Stem from Valve CL to Top of Rim
EXTSTEMC	Extended Stem from Valve CL to Indicator Cap
LCAP	Stem Ext. from Center of Valve to Top of Cap
LRIM	Stem Ext from Center of Valve to Top of Rim

# Actuator Options

## Advantage Actuators

Code	Description
<b>Fail Open</b>	
A133	3" or 4"
A147	3" or 4"
<b>Fail Close</b>	
A233	3" or 4" with 60# Spring
A234	3" or 4" with 90# Spring
A247	3" or 4" with 60# Spring
A248	3" or 4" with 80# Spring
<b>Double Acting</b>	
A333	3" or 4"
A347	3" or 4"

## Advantage 2.1 Actuators

Code	Description
<b>Fail Open</b>	
B103	Bio-Tek
B105	0.50"
B108	0.75" or 1.0"
B116	1.5" or 2.0"
<b>Fail Close</b>	
B203	Bio-Tek with 60# Spring
B204	Bio-Tek with 90# Spring
B205	0.50" with 60# Spring
B206	0.50" with 90# Spring
B208	0.50", 0.75" or 1.0" with 60# Spring
B209	0.75" or 1.0" with 90# Spring
B216	1.5" or 2.0" with 60# Spring
B217	1.5" or 2.0" with 90# Spring
<b>Double Acting</b>	
B303	Bio-Tek
B305	0.50"
B308	0.75" or 1.0"
B316	1.5" or 2.0"

Figure Number: 1-F-428L-6-0-0-TME-B209-

Actuator Options	Configuration Example	Code
	Actuator Options (select 1):	
	Advantage Actuator	
	Advantage 2.1 Actuator	B209
	Advantage Compact Stainless Actuator	
	Dia-Flo Actuator	
	Non ITT Actuation	

## Advantage Compact Stainless (ACS)

Code	Description
ACS1	Fail Open
ACS26	Fail Close with 60# Spring
ACS26S	Fail Close with 60# Spring, Sealed
ACS2S	Fail Close with 90# Spring, Sealed
ACS2	Fail Close with 90# Spring
ACS3	Double Acting

## Dia-Flo Actuators

Code	Description
<b>Fail Open</b>	
3112	#12
3125	#25
3126	#25 for Vacuum Service
3150	#50
31101	#101
31130	#130
31250	#250
<b>Fail Close</b>	
<b>Size #12</b>	
3213	88 Spring
3214	88 & 89 Springs
3215	88 & Raymond Springs
3216	89 Spring
<b>Size #25</b>	
3226	101 Spring
3227	101 & 102A Springs
3228	102A Spring

## Dia-Flo Actuators (cont.)

Code	Description
<b>Fail Close</b>	
<b>Size #50</b>	
3251	101 Spring
3252	101 & 102A Springs
3253	97 Spring
3254	96 Spring
3255	96 & 97 Springs
3256	102A Spring
<b>Size #75</b>	
3274	96 Spring
3276	96 & 97 Springs
3277	97 & 98 Springs
3278	96 & 98 Springs
3279	96, 97 & 98 Springs
<b>Size #101</b>	
32102	96 Spring
32103	98 Spring
32104	96 & 97 Springs
32105	96 & 98 Springs
32106	97 & 98 Springs
32107	96, 97, & 98 Springs
32108	130 Spring
32109	97 Spring
<b>Double Acting</b>	
<b>Size #130</b>	
32131	97 Spring
32132	96 Spring
32133	98 Spring
32134	96 & 97 Springs
32135	96 & 98 Springs
32136	97 & 98 Springs
32137	96, 97, & 98 Springs
32138	130 Spring
<b>Size #250</b>	
32251	129 & 130 Springs
32252	129 Spring
32253	130 Spring
3312	#12 Double Acting
3325	#25 Double Acting
3350	#50 Double Acting
3375	#75 Double Acting
33101	#101 Double Acting
33130	#130 Double Acting
33250	#250 Double Acting

## Non ITT Actuation

Code	Description
POF	Customer Supplied Actuator
POM	With Non-ITT Actuator

# Switches and Actuator Accessories

## Switches

### Integrated Switch Package

Code	Description
ISP-3W-HZ	3 Wire Discrete, without solenoid, without diagnostics
ISP-3W-BL-HZ	3 Wire Discrete, without solenoid, with diagnostics
ISP-3W-LS-HZ	3 Wire Discrete, without solenoid, without diagnostics
ISP-3W-LS-BL-HZ	3 Wire Discrete, without solenoid, with diagnostics
ISP-3W-SV-HZ	3 Wire Discrete, with internal solenoid, without diagnostics
ISP-3W-SV-BL-HZ	3 Wire Discrete, with internal solenoid, with diagnostics
ISP-3W-SV-BT-HZ	3 Wire Discrete, with internal solenoid, with diagnostics and control
ISP-3W-SV-LS-HZ	3 Wire Discrete, with internal solenoid, without diagnostics
ISP-3W-SV-LS-BL-HZ	3 Wire Discrete, with internal solenoid, with diagnostics
ISP-3W-SV-LS-BT-HZ	3 Wire Discrete, with internal solenoid, with diagnostics and control
ISP-AI-HZ	ASi, without solenoid, without diagnostics
ISP-AI-BL-HZ	ASi, without solenoid, with diagnostics
ISP-AI-LS-HZ	ASi, without solenoid, without diagnostics
ISP-AI-LS-BL-HZ	ASi, without solenoid, with diagnostics
ISP-AI-SV-HZ	ASi, with internal solenoid, without diagnostics
ISP-AI-SV-BL-HZ	ASi, with internal solenoid, with diagnostics
ISP-AI-SV-BT-HZ	ASi, with internal solenoid, with diagnostics and control
ISP-AI-SV-LS-HZ	ASi, with internal solenoid, without diagnostics
ISP-AI-SV-LS-BL-HZ	ASi, with internal solenoid, with diagnostics
ISP-AI-SV-LS-BT-HZ	ASi, with internal solenoid, with diagnostics and control
ISP-2W	2 Wire, without solenoid, without diagnostics
ISP-2W-LS	2 Wire, without solenoid, without diagnostics
ISP-2W-SV	2 Wire, with internal solenoid, without diagnostics
ISP-2W-SV-LS	2 Wire, with internal solenoid, without diagnostics
ISP-DN-HZ	DeviceNet, without solenoid, without diagnostics
ISP-DN-BL-HZ	DeviceNet, without solenoid, with diagnostics
ISP-DN-LS-HZ	DeviceNet, without solenoid, without diagnostics
ISP-DN-LS-BL-HZ	DeviceNet, without solenoid, with diagnostics
ISP-DN-SV-HZ	DeviceNet, with internal solenoid, without diagnostics
ISP-DN-SV-BL-HZ	DeviceNet, with internal solenoid, with diagnostics
ISP-DN-SV-BT-HZ	DeviceNet, with internal solenoid, with diagnostics and control
ISP-DN-SV-LS-HZ	DeviceNet, with internal solenoid, without diagnostics
ISP-DN-SV-LS-BL-HZ	DeviceNet, with internal solenoid, with diagnostics
ISP-DN-SV-LS-BT-HZ	DeviceNet, with internal solenoid, with diagnostics and control

### Value Switch Package

Code	Description
VSPG30	Gold Contacts 30V
VSPN	NAMUR Proximity
VSPP	3-Wire PNP Proximity
VSPS48	Silver Contacts 48V
VSPZ	2-Wire Proximity
VSP240	Silver Contacts 240V
VSP+G	Gold Contacts 24V
VSP+S	Silver Contacts 24V
VSP+N	NAMUR Proximity
VSP+P	3-Wire PNP Proximity

## Actuator Accessories

### Position Indicator (Dia-Flo Only)

Code	Description
P1	Position Indicator

## Limit Switches

Code	Description
LS1	Microswitch BZE6 - 2RN
LS2	Microswitch BAF1 - 2RN
LS3	Microswitch DTE6 - 2RN
LS4	Microswitch DTF2 - 2RN
LS5	Microswitch EXQ
LS6	Microswitch EXDQ
LS7	Microswitch LSA1A
LS8	Westlock 3479 Model 3
LS9	GO 74-13528-A1
LS9C	GO 73-13528-A2
LS11	Westlock E3479 MOD3
LS13	Westlock 9880
LS14	Westlock E9880
LS15	Westlock 99920-AB
LS16	Westlock 98810002BI
LS17	Westlock 98810002EI
LS41	Efector IN0117
LS42	Efector IN5331
LS78	StoneL PM3311SO2RS
LS79	StoneL PM3311SO2RL
LS128	Westlock 99P21A00000
LS129	Westlock 99P21AD550
LS168	STONEL PI33S11SA01RSA
LS 173	STONEL PI92S11SA15RSA
LS 179	STONEL PI92S1KSA15RSA
LSSpec	Special

### Limit Switches, Yoke Mounted

Code	Description
LS1Y	Microswitch BZE6 - 2RN
LS2Y	Microswitch BAF1 - 2RN
LS3Y	Microswitch DTE6 - 2RN
LS4Y	Microswitch DTF2 - 2RN
LS5Y	Microswitch EXQ
LS6Y	Microswitch EXDQ
LS7Y	Microswitch LSA1A
LS8Y	Westlock 3479 Model 3
LS9Y	GO 74-13528-A1
LS10Y	Namco EA700-80100
LS12Y	Namco EA170-34100/35100
PRSPEC	Special

## Mechanical Accessories

Code	Description
AO	Adjustable Opening Stop
AOH	Adjustable Opening Stop w/ Handwheel
AHODUP	Special Adjustable Opening Stop w/ Handwheel for Dupont
ATS	Adjustable Travel Stop
HWC	Hand Wheel Closing Device
HWO	Hand Wheel Opening Device
JO	Jack Opening Device (#32250)
THC	Adjustable Travel Stop, Handwheel Closing Device
TO	Adjustable Travel Stop, Adjustable Opening Stop
TOHC	Adjustable Travel Stop, Adjustable Opening Device, Handwheel Closing Device
TOHO	Adjustable Travel Stop, Adjustable Opening Stop, Handwheel Opening Device

## Mechanical Accessories

Code	Description
TOWO	Adjustable Travel Stop, Adjustable Opening Device, Wrench Opening Device
WO	Wrench Opening Device
XAO	Adjustable Opening Stop Sealed with Indicator
XAOL	Adjustable Opening Stop with Switch Mount
XOB	Adjustable Opening Stop - Bolt Assembly

## Manual Bonnet Switch

Code	Description
MBSWMG	Mechanical Gold (Close only)
MBSWMS	Mechanical Silver (Close only)

## Actuator Hardware Options

Code	Description
HW1	SS Airmotor Bolts
HW2	SS Accessory Brackets
HW3	SS Tubing and Fittings
HW4	Plastic Tubing /Brass Fittings
HW5	PVC Coated Tubing /Brass Fittings
HW6	PVC Coated Tubing /SS Fittings
HW9	PTFE Tubing and Stainless Steel Fittings
HW10	Breather Vent Filter Stainless Steel
HW11	Breather Vent Filter BRS

## Solenoid Valve

Code	Description
SV1	Asco 8320G184
SV2	Asco EF8320G184
SV3	Asco 8345G1
SV4	Asco EF8345G1
SV7	Asco 8302G202
SV8	Asco EF8320G202
SV14	Burkert Series 6012
SV15	Burkert Series 6014

## Solenoid Voltage

Code	Description
V1	120V / 60HZ
V2	24VDC
V3	240V / 60HZ
VSpec	Special

## Adjustable Opening Stop

Code	Description
XAO	Adjustable Opening Stop Sealed with Indicator
XAOL	Adjustable Opening Stop with Switch Mount
XOB	Adjustable Opening Stop - Bolt Assembly

## Speed Controllers

Code	Description
SC	Schrader 337-1001
SC2	Whitey needle valve SS-1RMA
SCSpec	Special

## Filter Regulators

Code	Description
FR1	Conoflow GFH60XTKEG3G
FR1X2	Two Conoflow GFH60XTKEG3G
FR2	Fisher 67FR
FR2X2	Two Fisher 67FR
FRSpec	Special

## Transducer

Code	Description
TR1	Conoflow GT2108ED
TR1630	Conoflow GT6108ED
TRCA	Controlair 550X
TRIPH	Moore IPH/4-20MA/3-15PSIG/20PSI/FR1/WDNS
TRWS	Watson Smith S3-4904-3XR
TRSpec	Special

## Positioners

Code	Description
PR1	Conoflow Model 31
PR2	Conoflow Model 33
PR3	Moore 73NF
PR4	Moore 73 NB
PR5	Moore 73 NR
PR6	Conoflow P50
PR7	Conoflow P51
PR8	Conoflow P52
PRSpec	Special
PR16	TMP-3000 Digital

## Signal Ranges

Code	Description
SR1	3-15 PSI
SR2	6-30 PSI
SR3	3-9 PSI
SR4	9-15 PSI

## Positioner Type

Code	Description
SNG10S	YTC TMP-3000 SNG10S
SNG11S	YTC TMP-3000 SNG11S

Figure Number: 1-F-428L-6-0-0-TME-B209-ISP-3W-HZ

	Configuration Example	ISP-3W-HZ																		
Switches and Actuator Accessories	Switch Packages (select 1):	ISP-3W-HZ																		
	ISP	ISP-3W-HZ																		
	VSP																			
	Limit Switches - Special																			
	Mechanical Accessories																			
	Manual Bonnet Switch																			
	Actuator Hardware Options																			
	Solenoid Valve																			
	Solenoid Voltage																			
	Speed Controllers																			
	Filter Regulators																			
	Transducer																			
	Positioners																			
	Signal Range																			
	Junction Box																			

# Service Preparation & Quality Documents

## Special Service Preparation

Code	Description
BAG	Cleaned and Bagged
DS	Dual Scale (PSI/BAR) Gauges
EU_SERVICE	European Union Service
NPC	No Polishing Compound
OXY	Oxygen
SIFREE	Silicone Free Preparation
SPEC	Customer Special
VAC	Vacuum

## Special Quality Documents

Code	Description
SQD2	C of C (seat & shell pressures)
SQD3	C of C Profilometer Tape for each body
SQD5	C of C Body/Stud/Nut CMTR and C of C to ASME Section VIII
SQD6	C of C Tube CMTR, Tank Bottom Valve
SQD7	C of C Weld Rod CMTR, Tank Bottom Valve

Figure Number: 1-F-428L-6-0-0-TME-36-M7-A209-VSPS48-SQD3

Configuration Example		SQD3
Special Service Preparation		
Special Quality Documents		SQD3

# Obsolete Figure Codes

Code	Description
<b>Body Type</b>	
RTBV	Radial Tank Bottom Valve
8D	Bio-Tek Forged 1.4435 SS
FD	Forged 1.4435 SS
<b>Body Ends (Buttweld)</b>	
423X	18 GA BT, Max Cutback , STD Length
423XL	18 GA BT, Max Cutback , Non-STD LG.
428X	16 GA Max Cut Standard Length
428XL	16 GA Max Cut Nonstandard Length
429X	14 GA Max Cut Standard Length
433	ANSI Flanged
489	RTBV, 90 Degree 16 GA Butt Weld
490	RTBV, 90 Degree Tri-Clamp
<b>Second End Code (Clamp)</b>	
X23X	18 GA BT, Max Cutback STD Length
X23XL	18 GA BT, Max Cutback Non-STD LG
X28X	16 GA BT, Max Cutback STD Length
X28L	By 16 Gauge Extended Tangent BW
X28XL	16 GA BT, Max Cutback Non-STD LG
X29L	By 14 Guage Extended Tangent BW
XX29X	14 GA BT, Max Cutback STD Length
<b>Bonnets, Handwheel</b>	
16	Standard Bio-Tek® Bonnet
17	Sealed Bio-Tek® Bonnet
902	Cast Iron Indicating
902S	Cast Iron Indicating - Sealed
912	Stainless Steel (316) Indicating
912S	Stainless Steel (316) Indicating - Sealed
932	Bronze Indicating
932S	Bronze Indicating - Sealed
933	Bronze Indicating with Travel Stop (1/2" - 4")
933S	Bronze Indicating with Travel Stop - Sealed (1/2" - 4")
942	Double Iron Indicating
942S	Double Iron Indicating - Sealed
943	Double Iron Indicating with Travel Stop
943S	Double Iron Indicating with Travel Stop - Sealed
950	Rising Handwheel with Travel Stop
961	Plastic PAS Non-Indicating with Travel Stop

Code	Description
<b>WFI Hot Lockout Bonnet</b>	
LBA	115VAC/60HZ
LBD	24VDC
LBD1	24VDC with Position feedback
LBM	24VDC with Mech Switch Output
LBP	24VDC with Solid State Switch Output
<b>Actuated Bonnets (Bronze)</b>	
33	Actuated
33S	Actuated - Sealed
<b>Optional Bonnet Internals</b>	
M2	Sanitary Internals
M11	316 Stainless Steel Stem
M12	PSU Cap
M13	Stainless Steel Compressor (Bio-Tek)
M14	Clear Cap
<b>Advantage Actuators</b>	
<b>Fail Open</b>	
A103	Bio-Tek
A105	0.50"
A108	0.50", 0.75" or 1.0"
A116	1.5" or 2.0"
<b>Fail Close</b>	
A203	Bio-Tek with 60# Spring
A204	Bio-Tek with 90# Spring
A205	0.50" with 60# Spring
A206	0.50" with 90# Spring
A208	0.50", 0.75" or 1.0" with 60# Spring
A209	0.75" or 1.0" with 90# Spring
A216	1.5" or 2.0" with 60# Spring
A217	1.5" or 2.0" with 90# Spring
<b>Double Acting</b>	
A303	Bio-Tek
A305	0.50"
A308	0.50", 0.75" or 1.0"
A316	1.5" or 2.0"
<b>Advantage Excel Actuators</b>	
AXS1	Fail Open
AXS26	Fail Close with 60# Spring
AXS29	Fail Close with 90# Spring
AXS3	Double Acting
AXS1S	Fail Open (Sealed Bonnet)
AXS26S	Fail Close with 60# Spring (Sealed Bonnet)
AXS29S	Fail Close with 90# Spring (Sealed Bonnet)
AXS3S	Double Acting (Sealed Bonnet)
<b>Junction Box</b>	
JB	Junction Box: Standard
JBSpec	Special

Code	Description
<b>Diaphragms</b>	
A	Soft Natural Rubber (FDA)
16	EPDM Compound 16 (FDA)
B16	Biotek EPDM Compound 16
C	Hypalon
H	EPDM (FDA)
NB	NB
R2	PTFE (FDA)
TM	PTFE (FDA)/Grade 16 BC
TFM1700	TFM1700 PTFE (FDA)
WB	White Butyl (FDA)
17	EPDM Compound 17 (FDA)
17HP	EPDM Compound 17 (FDA)
B17	Bio-Tek EPDM Compound 17
TM17	PTFE (FDA)/Grade 17 BC
TM17E	PTFE (FDA)/Grade 17E BC
<b>Switch Pack SP-2.5</b>	
SP5B	Effector IS-2002-AROA Proximity
SP5G	Gold Contacts - Mechanical
SP5GEU	Gold De-Rated to 70VDC/48VAC Max for EU Service - Mechanical
SP5N	NAMUR Proximity
SP5NP	3 Wire NPN Proximity
SP5P	3-Wire PNP Proximity
SP5S	Silver Contacts - Mechanical
SP5SEU	Silver De-Rated to 70VDC/ 48VAC Max for EU Service - Mechanical
SP5Z	2-Wire Proximity
<b>Switch Package SP-3</b>	
SP3S48	Silver Contacts 48V - Mechanical
SP3S48CL	Silver Contacts 48V w/ Clipped Resistor - Mechanical
SP3S110	Silver Contacts 110V - Mechanical
SP3S110CL	Silver Contacts 110V w/ Clipped Resistor - Mechanical
SP3S240	Silver Contacts 230V - Mechanical
SP3S240CL	Silver Contacts 230V w/ Clipped Resistor - Mechanical
SP3G30	Gold Contacts 30V - Mechanical
SP3G30CL	Gold Contacts 30V w/ Clipped Resistor - Mechanical
SP3GSA	Gold Contacts 30V, Simple Apparatus - No LEDs - Mechanical
SP3Z	2-Wire Proximity
SP3N	NAMUR Proximity
SP3P	3-Wire PNP Proximity
SP3NP	3 Wire NPN Proximity
<b>Solenoid Valve</b>	
SV5	Burkert 300-C-1/16 -F-R-1/8-VOL (Advantage)
SV6	Burkert 311-C-5/64 -F-BR-1/8-VOL (Advantage)
<b>Special Service Preparation</b>	
CS	Controlled Sulfur Body (0.005-0.017%)
SQDB	CMTR (Body)
SQD1	CMTR (body, tube, weld, weld rod)
SQDBIO	C of C Diaphragm USP XXVIII Class VI Biological Reactivity

# Sterile Access & GMP Fabrications

## Fabrication Type

Code	Description
GMP	GMP
HSA	Horizontal Sterile Access
SA	Sterile Access
SPEC	Special

## Purge Location

Code	Description
P1	Purge located closest to main valve end 1
P2	Purge located closest to main valve end 2
PB	Purge located at both valve ends (P1 and P2)

## Purge Valve Orientation

Code	Description
B	Back
F	Front
L	Left
LL	Left Special
LR	Left/Right Special
R	Right
RL	Right/Left Special
RR	Right Special

## Valve Number for Fabrication

Code	Description
M	Main Valve
2	Second Valve
3	Third Valve
4	Fourth Valve
5	Fifth Valve
6	Sixth Valve
7	Seventh Valve
8	Eighth Valve
9	Ninth Valve
10	Tenth Valve

Note: See pages 4-10 for additional figure numbers.

### Sterile Access Example

Sterile Access single valve fabrication with a 1.5" wrought stainless steel main valve and a 0.5" forged purge tube closest to the second end. The main valve has butt weld ends, 25 Ra polished interior, a 963 PAS manual bonnet and a modified PTFE diaphragm. The purge tube has a tri-clamp end.

Single Valve Fabrication Figure Number: SA-1.5-W-428L-.5-X19-P2-6-0-0-TME-963

Configuration Example		SA	1.5	W	428L	.5	X19	P2	6-0-0	TME	963			
Single Valve Fabrication	Fabrication Type	SA												
	Valve Size		1.5											
	Body Type			W										
	Body End Code				428L									
	Second End Code													
	Purge Tube Size					.5								
	Purge Tube End Code						X19							
	Purge Location								P2					
	Polish Selections (pg 5)									6-0-0				
	Diaphragm Selection (pg 5)										TME			
	Bonnets & Bonnet Options (pg 6)											963		
	Actuator Options (pg 7)													
Switches & Actuator Accessories (pg 8-9)														
Service Preparation & Quality Doc. (pg 10)														

### Sterile Access Orientations

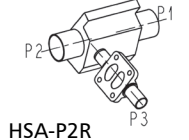
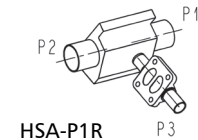
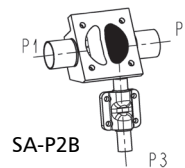
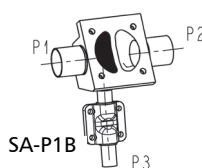
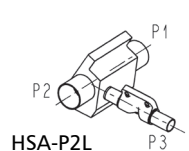
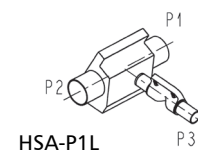
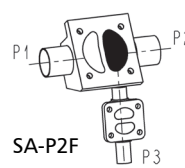
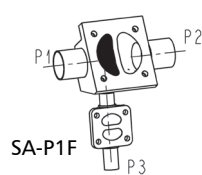
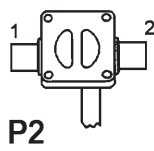
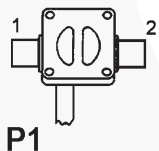

**GMP Example**

GMP two valve fabrication with a 2" wrought stainless steel main valve and a 0.5" forged purge valve closest to the second end and facing to the right. The main valve has Tri-Clamp ends, 25 Ra polished interior, a reverse acting advantage 2.0 actuator with a 60lb spring, an SP-2 switch pack with silver mechanical contacts and a modified PTFE diaphragm. The secondary valve has 16 gauge ends, 25-inch polished interior, a PAS hand-wheel operated bonnet with sanitary internals and a modified PTFE diaphragm.

**Fabrication Figure Number: GMP-2-2-.5**

Fabrication	Configuration Example	GMP	2	2	.5
	Fabrication Type				
	Two Valve Fabrication		2		
	Main Valve Size			2	
	Second Valve Size				.5

**Main Valve Figure Number: GMP-M-2-W-419-P2-R-6-0-0-TME-B216-ISP-3W-HZ**

Main Valve	Configuration Example	GMP	M	2	W	419		P2	R		6-0-0	TME		B216	ISP-3W-HZ
	Fabrication Type														
	Valve Number		M												
	Valve Size			2											
	Body Type				W										
	Body End Code					419									
	Second End Code														
	Purge Location							P2							
	Purge Valve Orientation								R						
	Tube Extensions														
	Polish Selections (pg 5)										6-0-0				
	Diaphragm Selection (pg 5)											TME			
	Bonnets & Bonnet Options (pg 6)													B216	
	Actuator Options (pg 7)														B216
	Switches & Actuator Accessories (pg 8-9)														
Service Preparation & Quality Doc. (pg 10)															

**Second Valve Figure Number: GMP-2-.5-F-428L-R-6-0-0-TME-963**

Second Valve	Configuration Example	GMP	2	.5	F	428L	R		6-0-0	TME	963			
	Fabrication Type													
	Valve Number		2											
	Valve Size			.5										
	Body Type				F									
	Body End Code					428L								
	Purge Valve Orientation						R							
	Tube Extensions													
	Polish Selections (pg 5)								6-0-0					
	Diaphragm Selection (pg 5)									TME				
	Bonnets & Bonnet Options (pg 6)										963			
	Actuator Options (pg 7)													
	Switches & Actuator Accessories (pg 8-9)													
	Service Preparation & Quality Doc. (pg 10)													

# Sterile Access & GMP Fabrications

## GMP Orientations

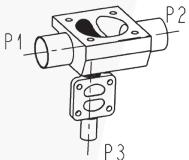
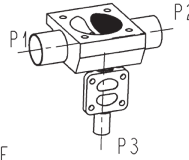
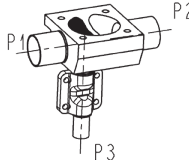
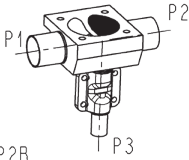
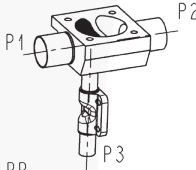
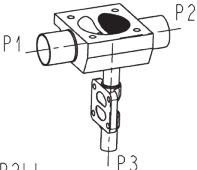
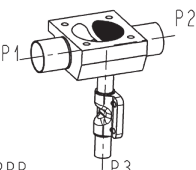
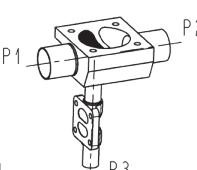
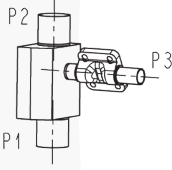
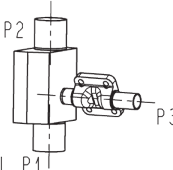
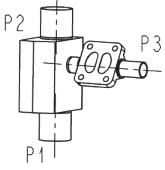
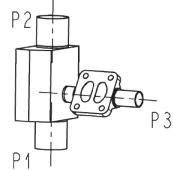
<i>GMP</i>			
 GMP-P1F	 GMP-P2F	 GMP-P1B	 GMP-P2B
 GMP-P1RR	 GMP-P2LL	 GMP-P2RR	 GMP-P1LL
 GMP-P2L	 GMP-P1L	 GMP-P2R	 GMP-P1R

# Zero Static Fabrications

## Fabrication Type

Code	Description
EZSBHV	Zero static E-Series U-Bend: Horizontal Tube - Vertical Valve
EZSBVV	Zero static E-Series U-Bend: Vertical Tube - Vertical Valve
ZDI	Zero static Dual Inline
ZDPT	Zero static Downstream Purge Top
ZDPB	Zero Static Downstream Purge Bottom
ZID	Zero static Inverted with Drain
ZSBT	Zero static Tee
ZSBT-BO	Zero static Block Body Tee with Back Outlet Option
ZSBBHV	Zero static Block Body U-Bend: Horizontal Tube - Vertical Valve
ZSBBVV	Zero static Block Body U-Bend: Vertical Tube - Vertical Valve
ZSBBS	Zero static Back to Back Sample Valve

## Fabrication Type (cont.)

Code	Description
ZSBV	Zero static Block Body with Vertical Run
ZSHH	Zero static Horizontal Tube - Horizontal Valve
ZSVH	Zero static Vertical Tube - Horizontal Valve
ZUD	Zero static with Upstream Sample and Downstream Purge

## Body Type

Code	Description
SVBT	Sample Valve Bio-Tek
SVPF	Sample Valve Pure-Flo

## Sample Valve Outlet Side

Code	Description
R	Ported on Right Side of Valve (Standard)
L	Ported on Left Side of Valve

## U Bend Tube Orientation (Optional)

Code	Description
HV	Horizontal U-Bend Tube with Vertical Valve Orientation
EHV	E-Series Horizontal U-Bend, Vertical Valve
VV	Vertical U-Bend Tube with Vertical Valve Orientation
EVV	E-Series Vertical U-Bend, Vertical Valve
USPEC	Special U-Bend Orientation

## Sample Valve Connection

Code	Description
419R	.75" Tri-Clamp
428	16 Gauge
419	Tri-Clamp Tube

ZSBT with a 1" wrought stainless steel main valve with Tri-Clamp end connection and a 2" tube with butt-weld ends, 25 Ra interior finish, standard exterior finish (Scotch Brite).

Figure Number: ZSBT-1-W-419-2-X28-6-1-0

Configuration Example		ZSBT	1	W	419	2	X28	6-1-0
Valve Body	Block Type	ZSBT						
	Valve Size		1					
	Body Type			W				
	Body End Connection				419			
	Zerostatic Tube Size					2		
	Zerostatic Tube End Connections						X28	
	Zerostatic Tube Second End Connection							
	Polish Selections							6-1-0

To add topworks, see page 38.

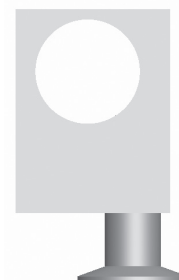
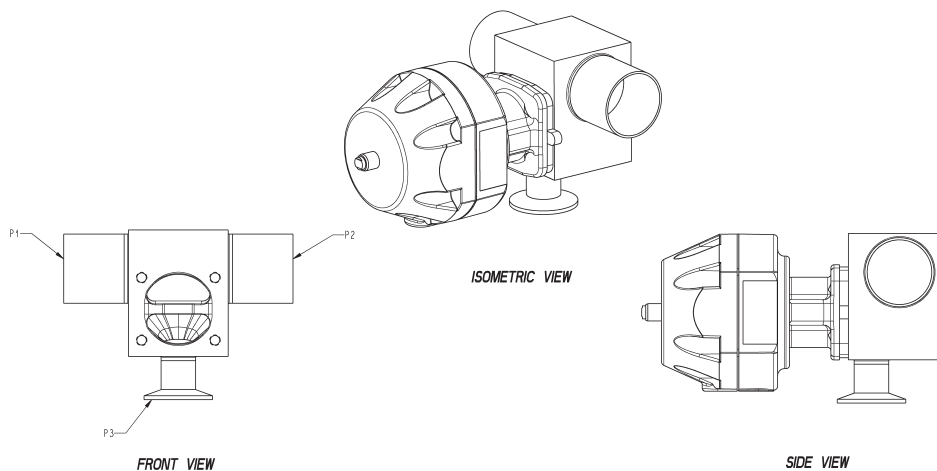

Please contact the factory for the latest drawing and dimensional information. The above drawing should only be used as a general reference.

# Zero Static Block Body U-bend (EZSBVV, EZSBHV)

.5" Zero Static Block, wrought stainless steel, 2" U-bend vertical tube, all three outlets have tri-clamp ends, 25 Ra interior finish, standard exterior finish (Scotch Brite), both interior and exterior electropolish.

Figure Number: EZSBVV-.5-W-419-2-X19-6-1-3

	Configuration Example	EZSBVV	.5	W	419	2	X19		6-1-3
Valve Body	Block Type <sup>1</sup>	EZSBVV							
	Valve Size		.5						
	Body Type <sup>2</sup>			W					
	Connection (P3)				419				
	Zerostatic Tube Size					2			
	Zerostatic Tube End Connection (P1,P2 or P1)						X19		
	Zerostatic Tube Second End Connection (P2) <sup>3</sup>								
	Polish Selections								6-1-3

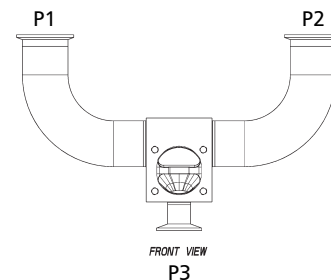

<sup>1</sup> EZSBVV for vertical tube, vertical valve. EZSBHV for horizontal tube, vertical valve. See drawings below for vertical tube and horizontal tube examples.

<sup>2</sup> For Bio-Tek BW is used.

<sup>3</sup> Second end connection can be provided if end connections are different.

To add topworks, see page 38.

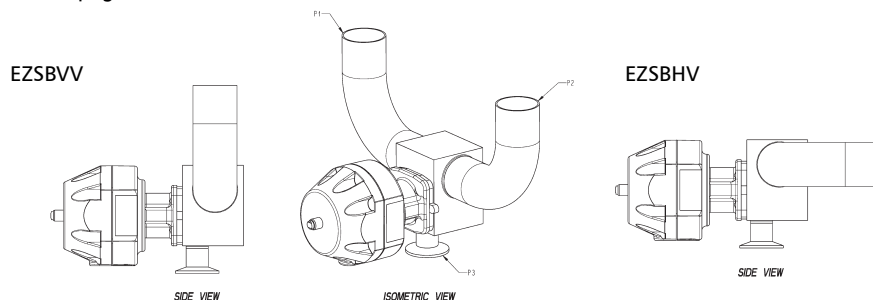

Please contact the factory for the latest drawing and dimensional information. The above drawing should only be used as a general reference.

# Zero Static Back to Back Sample (ZSBBS)

Zero Static Block Body with a 2" wrought stainless steel main valve and a 4" tube, all three outlets are butt-weld, Bio-Tek sample valve with .75" Tri-Clamp connection, 25 Ra interior finish, standard exterior finish (Scotch Brite).

Figure Number: ZSBBS-2-428-4-428-.5-SVBT-419R-R-W-6-1-0

	Configuration Example	ZSBBS	2	428	4		428	.5	SVBT	419R	R	W	6-1-0
Valve Body	Block Type	ZSBBS											
	Valve Size		2										
	Body End Connection (P3)			428									
	Zerostatic Tube Size				4								
	U-Bend Tube Orientation <sup>1</sup>												
	Zerostatic Tube End Connections (P1,P2)						428						
	Second Valve Size							.5					
	Second Valve Type (.5" only) <sup>2</sup>								SVBT				
	Second Valve End Connection (P4) <sup>3</sup>									419			
	Sample Outlet Side										R		
	Body Material											W	
	Polish Selections												6-1-0

<sup>1</sup> For a U-Bend Vertical Tube, enter VV. For Horizontal Tube, enter HV. See drawings below for vertical tube and horizontal tube examples.

<sup>2</sup> For .5 inch valve, must specify Pure-Flo (PF) or Bio-Tek (BT). PF is recommended for steam applications.

<sup>3</sup> 419R refers to .75 x .5 reducing Tri-Clamp port connection required for drainability. .5" sample port is available upon request. To add topworks, see page 38.

Main Multiport Valve Topworks Figure Number: .75-N-TME-963

	Configuration Example	.75	N	TME	963
Topworks	Valve Size	.75			
	Body (Not Supplied)		N		
	Diaphragm (pg 5)			TME	
	Bonnet (pg 6)				963
	Options (pg 7-9)				

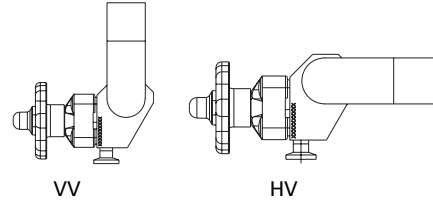

Sample Multiport Valve Topworks Figure Number: .5-N-TM17-18

	Configuration Example	.5	N	TME	18
Topworks	Valve Size	.5			
	Body (Not Supplied)		N		
	Diaphragm (pg 5)			TME	
	Bonnet (pg 6)				18
	Options (pg 7-9)				

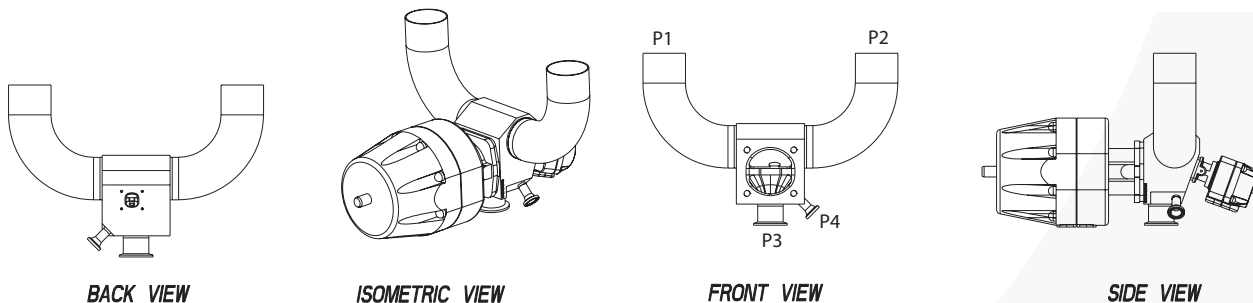
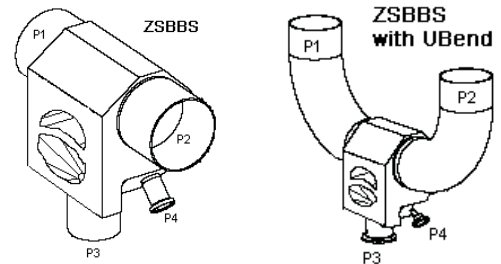

Please contact the factory for the latest drawing and dimensional information. The above drawing should only be used as a general reference.

# Zero Static Dual Inline

2" Zero Static Dual Inline, wrought stainless steel, U-bend vertical tube, 2" run, with 16 ga buttweld ends, Tri-clamp valve outlet end connection, 25 Ra interior finish, standard exterior finish (Scotch Brite).

Figure Number: ZDI-2-419-2-VV-428-2-W-6-1-0

	Configuration Example	ZDI	2	419	2	VV	428	2	W	6-1-0
Valve Body	Block Type	ZDI								
	Valve Size		2							
	Body End Connection (P3)			419						
	Zerostatic Tube Size				2					
	U-Bend Orientation <sup>1</sup>					VV				
	Zerostatic Tube End Connections (P2,P2)						428			
	Second Valve Size							2		
	Body Material								W	
	Polish Selections									6-1-0

<sup>1</sup> For a U-Bend Vertical Tube, enter VV. For Horizontal Tube, enter HV. See drawings below for vertical tube and horizontal tube examples.  
To add topworks, see page 38.

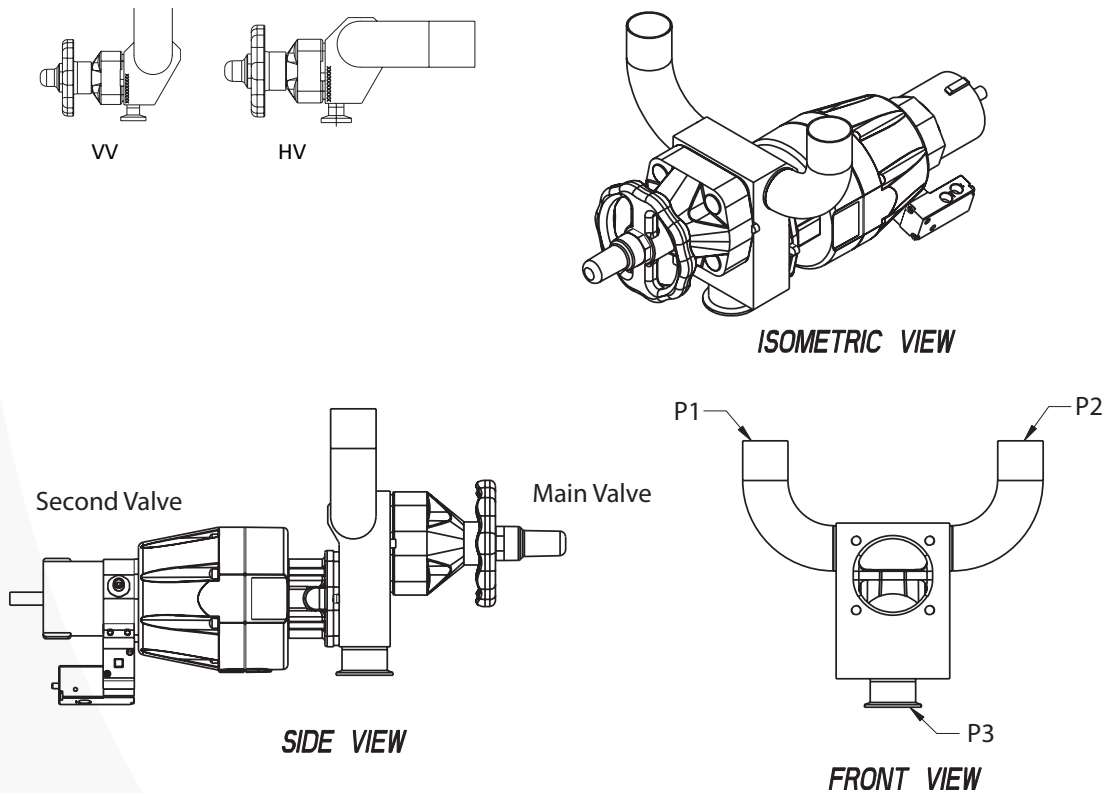

Please contact the factory for the latest drawing and dimensional information. The above drawing should only be used as a general reference.

# Zero Static Downstream Purge (ZDPT)

Zero Static Block Body, wrought stainless steel, U-bend vertical tube, 1" main valve with Tri-Clamp end connection, 2" run with buttweld ends, .5" Pure-Flo purge with Tri-Clamp connection, 25 Ra interior finish, standard exterior finish (Scotch Brite). Please note the ZDPT secondary valve outlet position is above the secondary valve weir. The ZDPT is equivalent to the superseded ZDP design.

Figure Number: ZDPT-1-419-2-VV-428-.5-SVPF-419-R-W-6-1-0

	Configuration Example	ZDPT	1	419	2	VV	428	.5	SVPF	419	R	W	6-1-0
Valve Body	Block Type	ZDPT											
	Valve Size		1										
	Body End Connection			419									
	Zerostatic Tube Size				2								
	U-Bend Orientation <sup>1</sup>					VV							
	Zerostatic Tube End Connection						428						
	Second Valve Size							.5					
	Second Valve Type								SVPF				
	Second Valve End Connection									419			
	Second Valve Outlet Orientation										R		
	Body Material											W	
	Polish Selections												6-1-0

<sup>1</sup> For a U-Bend Vertical Tube, enter VV. For Horizontal Tube, enter HV. See drawings below for vertical tube and horizontal tube examples. To add topworks, see page 38.

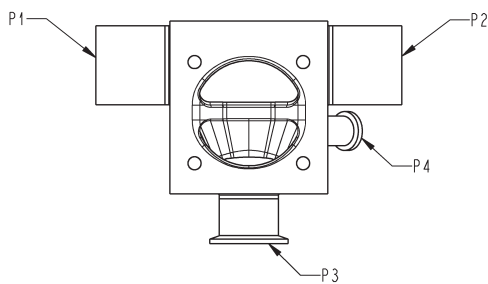
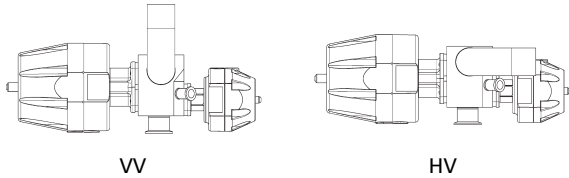
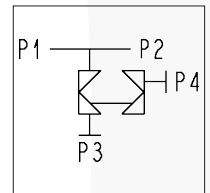

FRONT VIEW

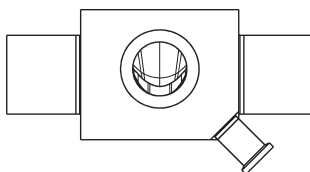

BOTTOM VIEW

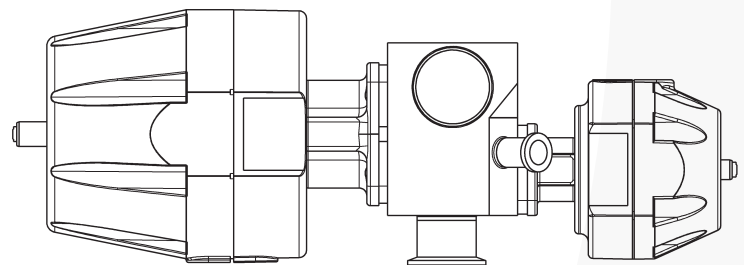

SIDE VIEW

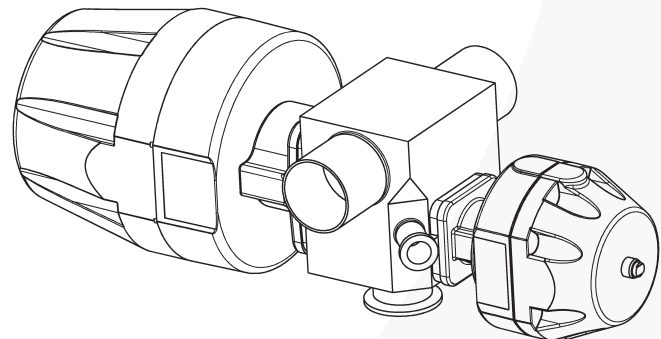

ISOMETRIC VIEW

Please contact the factory for the latest drawing and dimensional information. The above drawing should only be used as a general reference.

# Zero Static Downstream Purge (ZDPB)

Zero Static Block Body, wrought stainless steel, U-bend vertical tube, 1" main valve with Tri-Clamp end connection, 2" run with buttweld ends, .5" Pure-Flo purge with Tri-Clamp connection, 25 Ra interior finish, standard exterior finish (Scotch Brite). Please note the ZDPB secondary valve outlet position is below the secondary valve weir.

Figure Number: ZDPB-1-419-2-VV-428-.5-SVPF-419-R-W-6-1-0

	Configuration Example	ZDPB	1	419	2	VV	428	.5	SVPF	419	R	W	6-1-0
Valve Body	Block Type	ZDPB											
	Valve Size		1										
	Body End Connection			419									
	Zerostatic Tube Size				2								
	U-Bend Orientation <sup>1</sup>					VV							
	Zerostatic Tube End Connection						428						
	Second Valve Size							.5					
	Second Valve Type								SVPF				
	Second Valve End Connection									419			
	Second Valve Outlet Orientation										R		
	Body Material											W	
Polish Selections												6-1-0	

<sup>1</sup> For a U-Bend Vertical Tube, enter VV. For Horizontal Tube, enter HV. See drawings below for vertical tube and horizontal tube examples. To add topworks, see page 38.

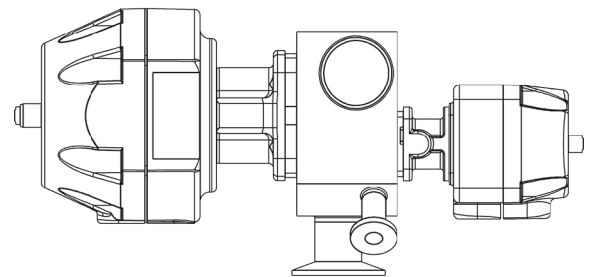
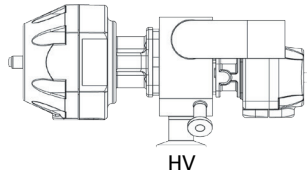
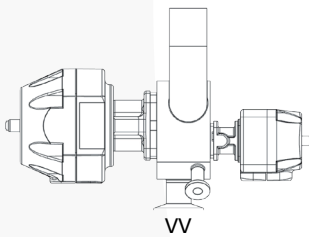
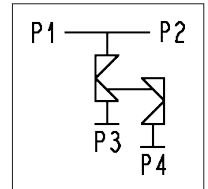

SIDE VIEW

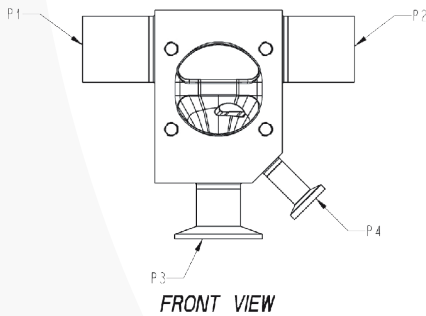

FRONT VIEW

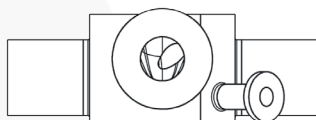

BOTTOM VIEW

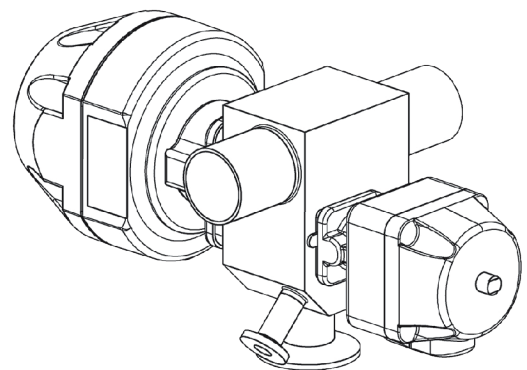

ISOMETRIC VIEW

Please contact the factory for the latest drawing and dimensional information. The above drawing should only be used as a general reference.

# Zero Static Inverted with Drain (ZID)

1" Inverted Zero Static with Drain, 2" Zero Static tube size, wrought stainless steel body, Tri-Clamp ends, .5" Bio-Tek Second Valve with Tri-Clamp outlet connection on right side of valve, 25 Ra interior finish, standard exterior finish (Scotch Brite).

Figure Number: ZID-1-419-2-419-.5-SVBT-419-W-6-1-0

	Configuration Example	ZID	1		419	2	419	.5	SVBT	419	W	6-1-0
Valve Body	Block Type	ZID	1		419	2	419	.5	SVBT	419	W	6-1-0
	Main Valve Size		1									
	Main Valve Type (.5" only) <sup>1</sup>											
	Main Valve End Connection				419							
	Zerostatic Tube Size					2						
	Zerostatic Tube End Connections						419					
	Second Valve Size							.5				
	Second Valve Type (.5" only) <sup>1</sup>								SVBT			
	Second Valve End Connection									419		
	Body Material										W	
	Polish Selections											6-1-0

<sup>1</sup> For .5 inch valve, must specify Pure-Flo (PF), Bio-Pure (BP) or Bio-Tek (BT).

To add topworks, see page 38.

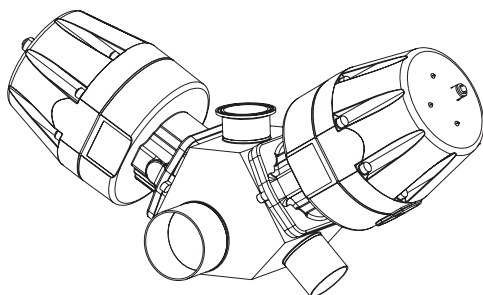

ISOMETRIC VIEW

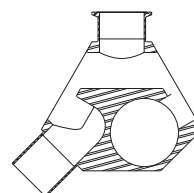

SECTION A-A

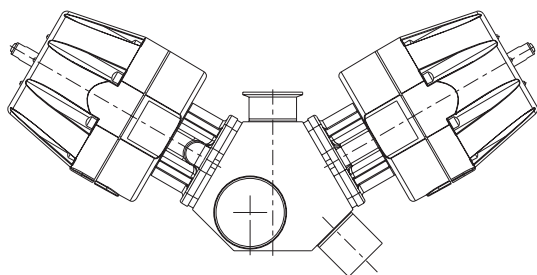

FRONT VIEW

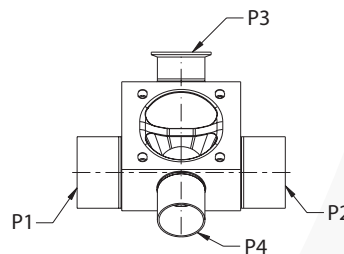

SIDE VIEW

Please contact the factory for the latest drawing and dimensional information. The above drawing should only be used as a general reference.

# Zero Static Block Body with Back Outlet Option (ZSBT-BO)

1" Zero Static Block with Back Outlet, wrought stainless steel, Tri-Clamp end connection, 2" cross tube (run) with butt weld ends, 25 Ra interior finish, standard exterior finish (Scotch Brite).

Figure Number: ZSBT-BO-2-W-419-4-X29-6-1-0

	Configuration Example	ZSBT	BO	2	W	419	4	X29	6-1-0
Valve Body	Block Type	ZSBT							
	Zero Static Option		BO						
	Valve Size			2					
	Material				W				
	Body End Connection					419			
	Zerostatic Tube Size						4		
	Zerostatic Tube End Connection							X29	
	Polish Selections								6-1-0

To add topworks, see page 38.

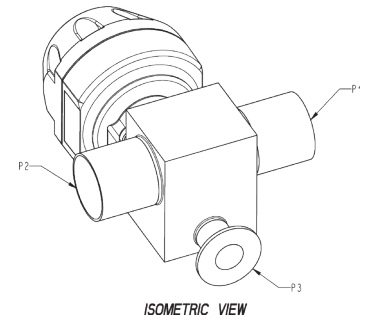
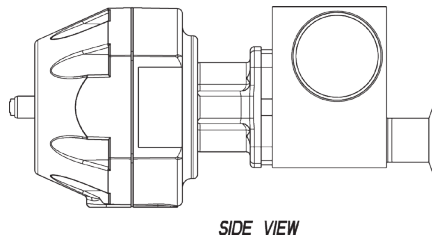
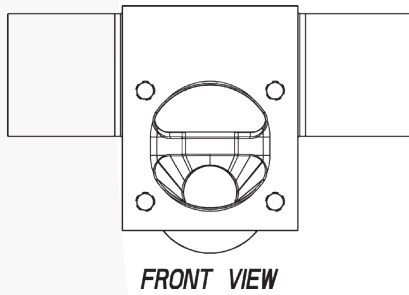

Please contact the factory for the latest drawing and dimensional information. The above drawing should only be used as a general reference.

# Zero Static Block Body with Vertical Run (ZSBV)

ZSBV with a 2" wrought stainless steel main valve with Tri-Clamp end connection and a 2" tube with buttweld ends, 25 Ra interior finish, standard exterior finish (Scotch Brite).

Figure Number: ZSBV-R-2-428-2-X28-W-6-1-0

	Configuration Example	ZSBV	R	2	428	2	X28	W	6-1-0
Valve Body	Block Type	ZSBV							
	Left or Right Option		R						
	Valve Size			2					
	Body End Connection				428				
	Zerostatic Tube Size					2			
	Zerostatic Tube End Connection						X28		
	Body Material							W	
	Polish Selections								6-1-0

To add topworks, see page 38.

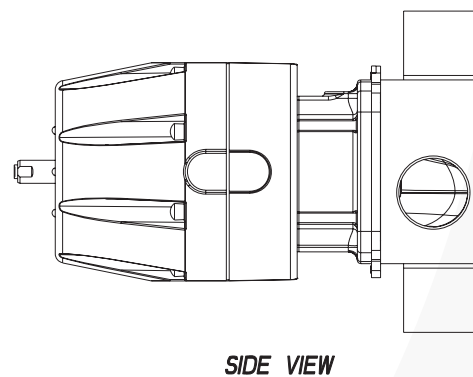
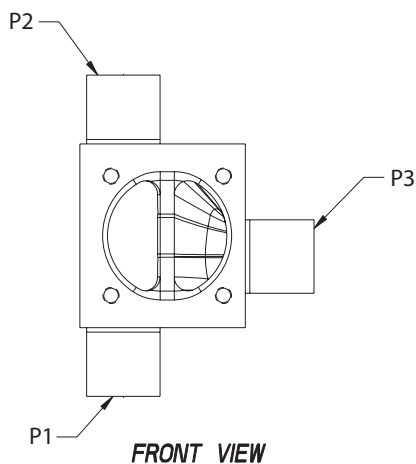
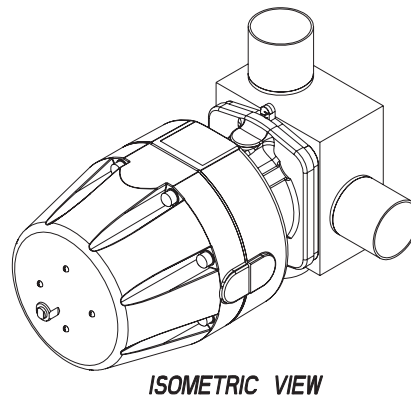

Please contact the factory for the latest drawing and dimensional information. The above drawing should only be used as a general reference.

# Zero Static with Upstream Sample and Downstream Purge (ZUD)

1" ZUD wrought stainless steel body with 0.5" Bio-Tek Upstream Sample (right side) and 0.5" Pure-Flo Downstream Purge. Tri-Clamp main valve end connection. 2" Zero Static tube size with 16 ga buttweld ends. (Sample valve with 0.75" reducing ferrule and purge valve with 0.5" Tri-Clamp end connection.) 25 Ra interior finish, standard exterior finish (Scotch Brite).

Figure Number: ZUD-1-419-2-428-.5-SVBT-419R-R-.5-TVPF-419-W-6-1-0

	Configuration Example	ZUD	1	419	2	428	.5	SVBT	419R	R	.5	TVPF	419	W	6-1-0
Valve Body	Block Type	ZUD													
	Main Valve Size		1												
	Main Valve End Connections (P3)			419											
	Zerostatic Tube Size				2										
	U-Bend Orientation <sup>1</sup>														
	Zerostatic Tube End Connections (P1,P2)					428									
	Second Valve Size						.5								
	Second Valve Type (.5" only) <sup>2</sup>							SVBT							
	Second Valve End Connection (P4) <sup>3</sup>								419R						
	Second Valve Outlet Orientation									R					
	Third Valve Size										.5				
	Third Valve Type (.5" only) <sup>2</sup>											TVPF			
	Third Valve End Connection (P5)												419		
	Body Material													W	
Polish Selections														6-1-0	

<sup>1</sup> For a U-Bend Vertical Tube, enter VV. For Horizontal Tube, enter HV. See drawings below for vertical tube and horizontal tube examples.

<sup>2</sup> For .5 inch valve, must specify Pure-Flo (PF), Bio-Pure (BP) or Bio-Tek (BT). PF is recommended for steam applications. .5" sample port is available upon request.

<sup>3</sup> 419R refers to .75 x .5 reducing Tri-Clamp port connection required for drainability.

Note: All second and third valve options shown above are standard.

To add topworks, see page 38.

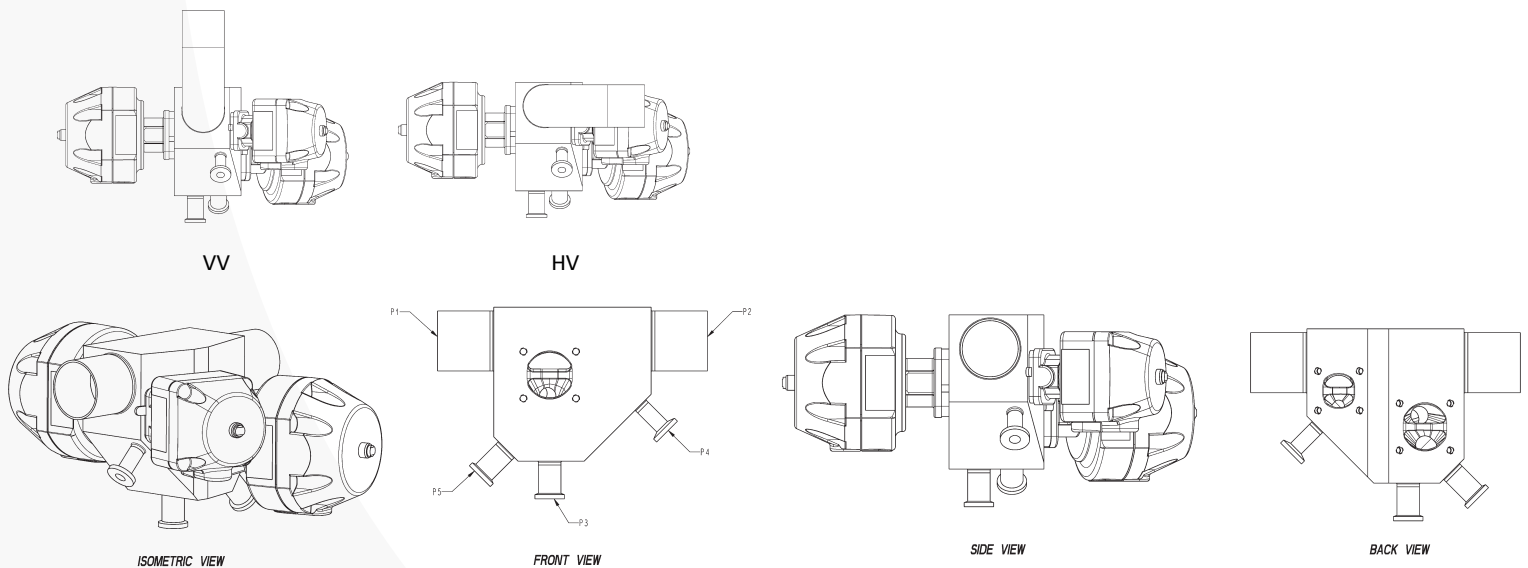

Please contact the factory for the latest drawing and dimensional information. The above drawing should only be used as a general reference.

# Multiport Valves

## Type of Valve

Code	Description
BBD	Block and Bleed Drain
BBV	Block and Bleed Vent
BYP	Pure-Flo Valve with Bypass Option
CHRO	Chromatography
CHN	Chromatography without Bypass
CRO	Cross over
CROD	Cross over with Drain Angle
DF	Dual Flow
DV2E	E-Series Divert Valve 2-way
DV2W	Divert Valve 2-way
DV2WS	Sterile Tank Vent Filter Shunt
DV3W	Divert Valve 3-way
DV4W	Divert Valve 4-way
DV5W	Divert Valve 5-way
DV6W	Divert Valve 6-way
HDV3W	Horizontal Divert Valve 3-way
IDSA	Integral Dual Sterile Access
IHSA	Integral Horizontal Sterile Access
INV_ISG	Inverted ISG
ISG	Integral Sterile Access GMP
SB1	Integral Sterile Barrier
VSPEC	Special Valve Type

## Type

Code	Description
BP	Bio-Pure
PF	Pure-Flo
BT	Bio-Tek

## Outlet Option

Code	Description
1	Outlet Configuration 1
2	Outlet Configuration 2
3	Outlet Configuration 3
4	Outlet Configuration 4
5	Outlet Configuration 5
6	Outlet Configuration 6
7	Outlet Configuration 7
8	Outlet Configuration 8
OSPEC	Special Outlet Configuration

Note: Refer to the drawing that corresponds to the type chosen

## Material

Code	Description
W	Wrought 316L
WA	Wrought AL6XN
WC2	Wrought C-22
WC6	Wrought C-276
WT	Wrought Titanium
BSPEC	Special Material

## Flow Through (Optional)

Code	Description
DVFT	Divert Flow-Through

Note: See pages 4-10 for additional figure numbers.

# Block and Bleed Valve

1.5" Block and Bleed, wrought stainless steel, Tri-Clamp ends, 25 Ra interior finish, standard exterior finish (Scotch Brite).

Figure Number: BBD-1.5-419-W-6-1-0

Valve Body	Configuration Example	BBD	1.5		419	W	6-1-0
	Block Type	BBD					
	Valve Size		1.5				
	Type (.5" only) <sup>1</sup>						
	Body End Connections (P1, P2, P3) <sup>2</sup>				419		
	Body Material					W	
	Polish Selections						6-1-0

<sup>1</sup> For .5 inch valve, must specify Pure-Flo (PF) or Bio-Tek (BT).

<sup>2</sup> Contact the factory for additional options for discrete end connection selections. To add topworks, see page 38.

BBD

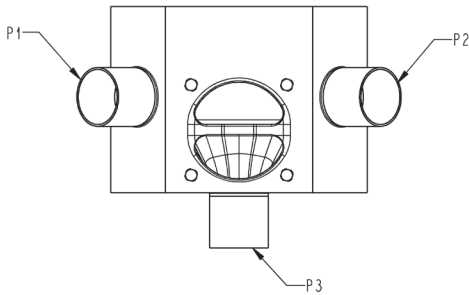

FRONT VIEW

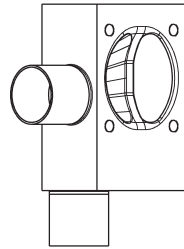

SIDE VIEW

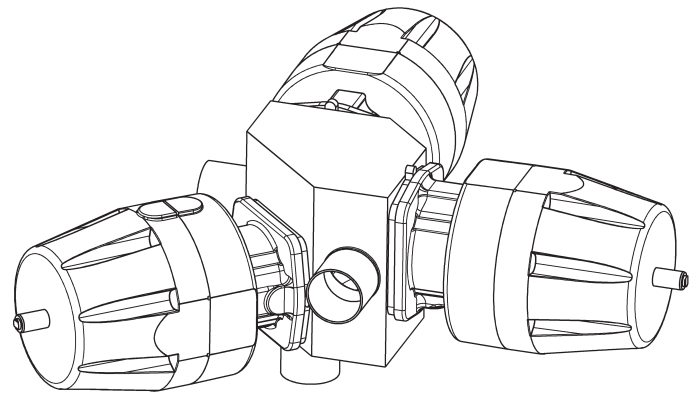

ISOMETRIC VIEW

BBV

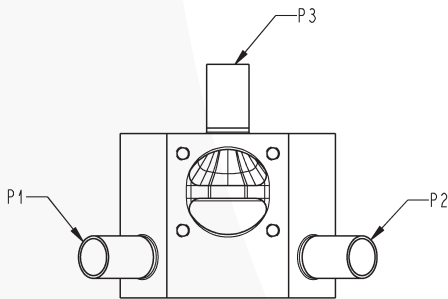

FRONT VIEW

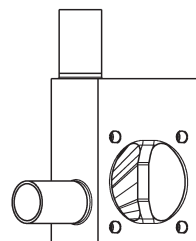

SIDE VIEW

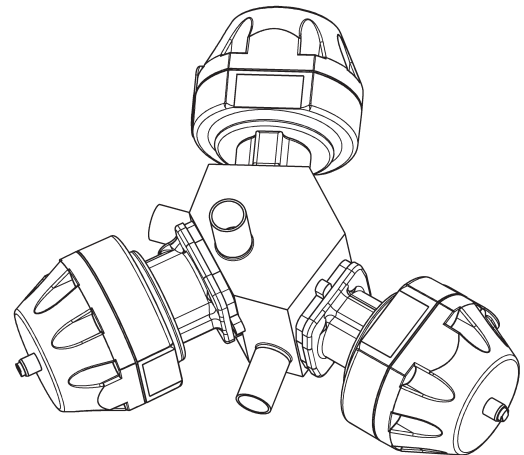

ISOMETRIC VIEW

Please contact the factory for the latest drawing and dimensional information. The above drawing should only be used as a general reference.

# Bypass Valve

.5" wrought stainless steel valve with Bypass, Tri-Clamp ends, 25 Ra interior finish, standard exterior finish (Scotch Brite).

Figure Number: BP-1-419-.25-W-6-1-0

Valve Body	Configuration Example	BP	.5	419	.25	W	6-1-0
	Block Type	BP					
	Valve Size <sup>1</sup>		.5				
	Body End Connections (P1, P2)			419			
	Second Valve Size <sup>2</sup>				.25		
	Body Material					W	
	Polish Selections						6-1-0

<sup>1</sup> Available in .5" - 3" valve sizes. Note: Valve sizes 1.5" and larger are manufactured on a forged body.  
<sup>2</sup> 1/4" standard bypass valve size (internal passage diameter .18"). Consult the factory for additional bypass valve sizes. To add topworks, see page 38.

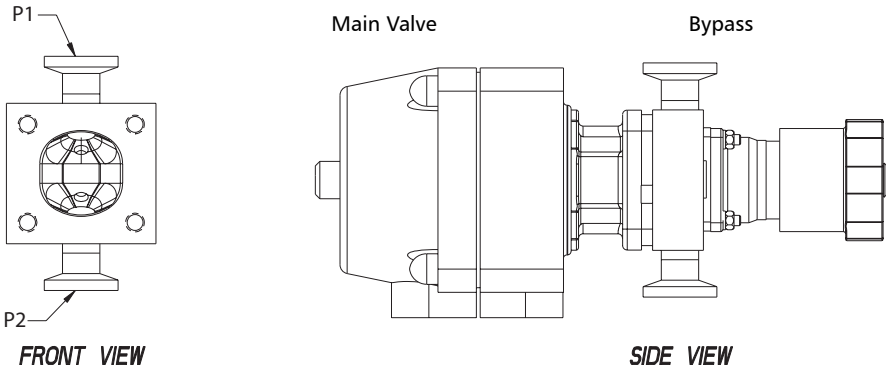
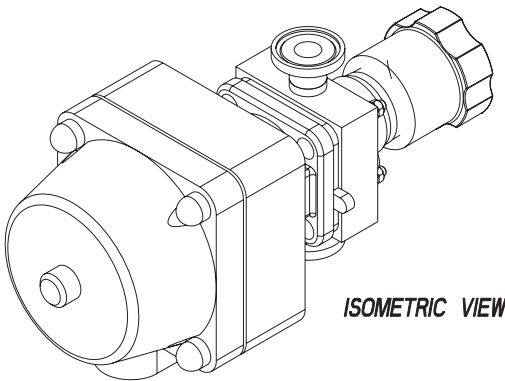

Please contact the factory for the latest drawing and dimensional information. The above drawing should only be used as a general reference.

# Chromatography Valve (CHRO, CHN)

2" Chromatography Valve with Bypass, wrought stainless steel body, Tri-Clamp ends, standard mounting holes, 25 Ra interior finish, standard exterior finish (Scotch Brite).

Figure Number: CHRO-2-419-W-SM-6-1-0

Main Valve	Configuration Example	CHRO	2	419	W	SM	6-1-0
	Block Type <sup>1</sup>	CHRO					
	Valve Size		2				
	Type (.5" only) <sup>2</sup>						
	End Connections			419			
	Body Material				W		
	Standard Mounting <sup>3</sup>					SM	
	Polish Selections						6-1-0

<sup>1</sup> Chromatography block includes bypass valve as a standard (CHRO). Use Block Type CHN for Chromatography block with no bypass valve.

<sup>2</sup> For .5 inch valve, must specify Pure-Flo (PF) or Bio-Tek (BT).

<sup>3</sup> Standard mounting for Chromatography blocks consists of drilled and tapped holes on the bottom of the block. Contact factory for specific sizes and locations. Body can be mounted horizontally (as shown below) or vertically with port P1 at the top.

To add topworks, see page 38.

CHRO

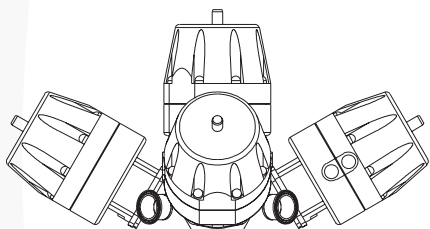

SIDE VIEW

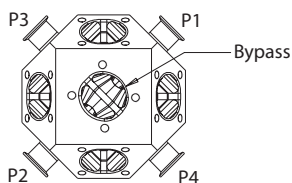

TOP VIEW

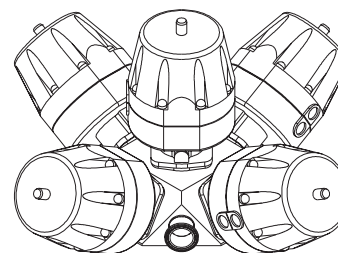

ISOMETRIC VIEW

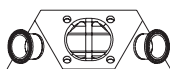

FRONT VIEW

CHN

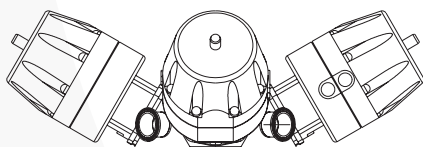

FRONT VIEW

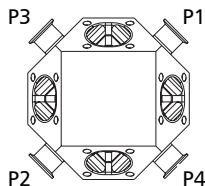

TOP VIEW

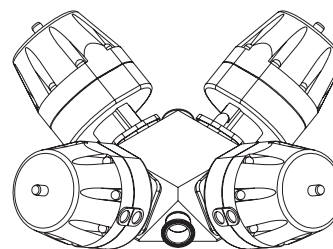

ISOMETRIC VIEWS

Please contact the factory for the latest drawing and dimensional information. The above drawing should only be used as a general reference.

# Crossover Valve (CROD, CRO)

1" Crossover with Drain Angle, wrought stainless steel, Tri-Clamp end connections, 25 Ra interior finish, standard exterior finish (Scotch Brite)

Figure Number: CROD-1-419-W-6-1-0

Main Valve	Configuration Example	CROD	1	419	W	6-1-0
	Block Type	CROD				
	Valve Size		1			
	Type (.5" only) <sup>1</sup>					
	Body End Connections (P1-P4)			419		
	Body Material				W	
	Polish Selections					6-1-0

<sup>1</sup> For .5 inch valve, must specify Pure-Flo (PF) or Bio-Tek (BT).  
To add topworks, see page 38.

## CROD

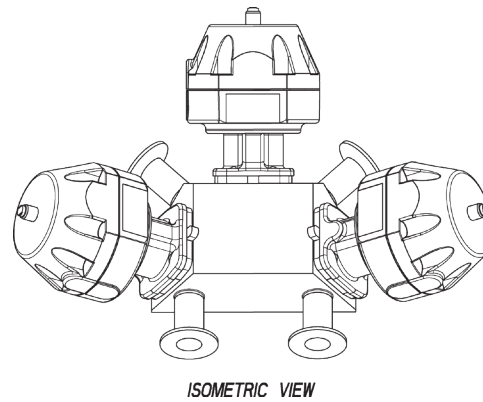
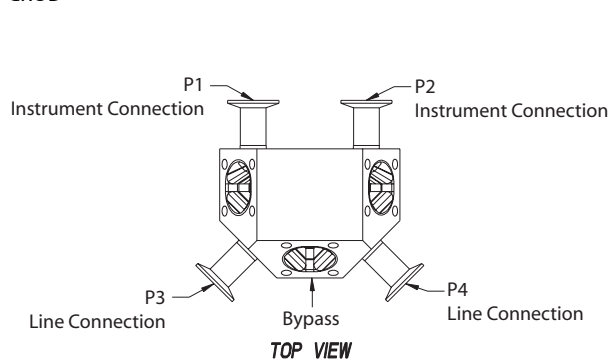

## CRO

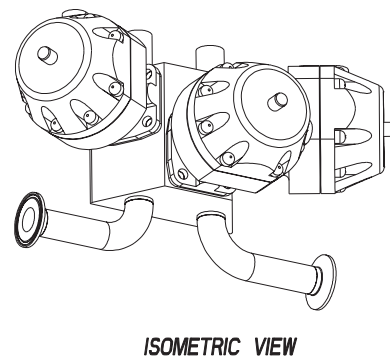
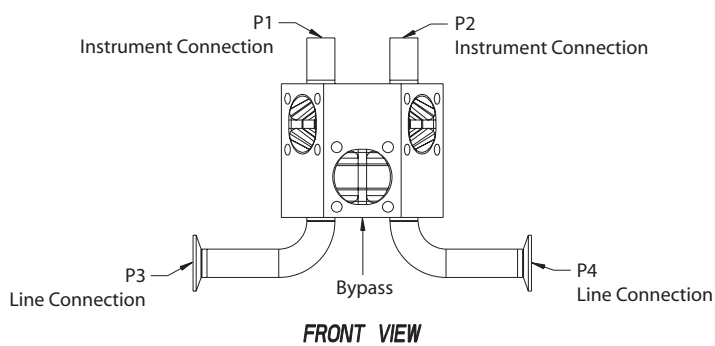

Please contact the factory for the latest drawing and dimensional information. The above drawing should only be used as a general reference.

# Multiport Divert Valve (DV2E, DV3W, DV4W, DV5W, DV6W)

## 2-Way

2-Way Divert Valve with a 1" wrought stainless steel body, inlet and outlets have Tri-Clamp ends, outlet is Option 4, 25 Ra interior finish, standard exterior finish (Scotch Brite).

Figure Number: DV2E-1-4-419-PP1-419-W-SM-6-1-0

	Configuration Example	DV2E	1		4		419		PP1	419	W	SM	6-1-0
Valve Body	Block Type	DV2E											
	Valve Size		1										
	Type (.5" only) <sup>1</sup>												
	Outlet Option <sup>2</sup>				4								
	Common Port Size <sup>3</sup>												
	End Connections <sup>4</sup>						419						
	Common Port End Connection (P1) <sup>5</sup>												
	Porting <sup>6</sup>								PP1				
	Port Connection <sup>7</sup>									419			
	Body Material										W		
	Mounting Holes <sup>8</sup>											SM	
	Polish Selections												6-1-0

## 3-Way Through 6-Way

3-Way Divert Valve with a 1.5" wrought stainless steel body, inlet and outlets have Tri-Clamp ends, outlet is Option 4, 25 Ra interior finish, standard exterior finish (Scotch Brite).

Figure Number: DV3W-1-4-1.5-DVFT-419-X28-W-SM-6-1-0

	Configuration Example	DV3W	1		4	1.5	DVFT	419	X28	W	SM	6-1-0
Valve Body	Block Type <sup>9</sup>	DV3W										
	Valve Size		1									
	Type (.5" only) <sup>1</sup>											
	Outlet Option <sup>2</sup>				4							
	Common Port Size <sup>3</sup>					1.5						
	Divert Valve Flow Through <sup>10</sup>						DVFT					
	End Connections <sup>4</sup>							419				
	Common Port End Connection (P1) <sup>5</sup>								X28			
	Body Material									W		
	Mounting Holes <sup>8</sup>										SM	
	Polish Selections											6-1-0

<sup>1</sup> For .5 inch valve, must specify Pure-Flo (PF), Bio-Pure (BP) or Bio-Tek (BT).

<sup>2</sup> See page 31 for outlet options.

<sup>3</sup> Common Port Size - provides the option of a larger common port (P1) size than the valve size (to increase flow when more than one valve is open).

<sup>4</sup> Contact the factory for discrete end connection selections.

<sup>5</sup> Common Port End Connection - provides the option of a different end connection for the Common Port (P1).

<sup>6</sup> Porting (for the 2-way divert only) - out the bottom of the valve, typically for drain ports. Consult the factory for additional details.

<sup>7</sup> Port Connection - is required if Porting is selected. Designates the port end connection(s).

<sup>8</sup> Contact factory for mounting options.

<sup>9</sup> Figure numbers for Block Type: 3-Way - DV3W, 4-Way - DV4W, 5-Way - DV5W, 6-Way - DV6W.

Note: Combinations with more than six diverted ports are possible but are typically not recommended due to the internal deadleg.

<sup>10</sup> Divert Valve Flow Through (3 through 6-Way only) - provides an additional common port from the opposite side of the block.

To add topworks, see page 38.

Contact the factory for additional options.

## Outlet Options

2-Way

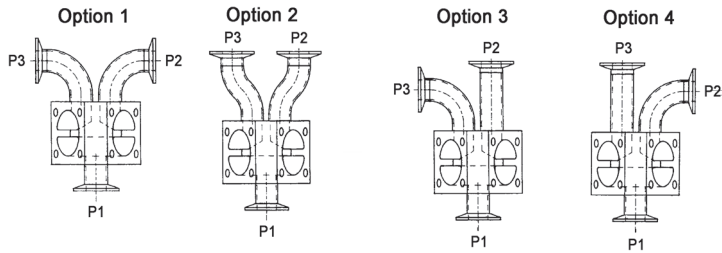

3-Way

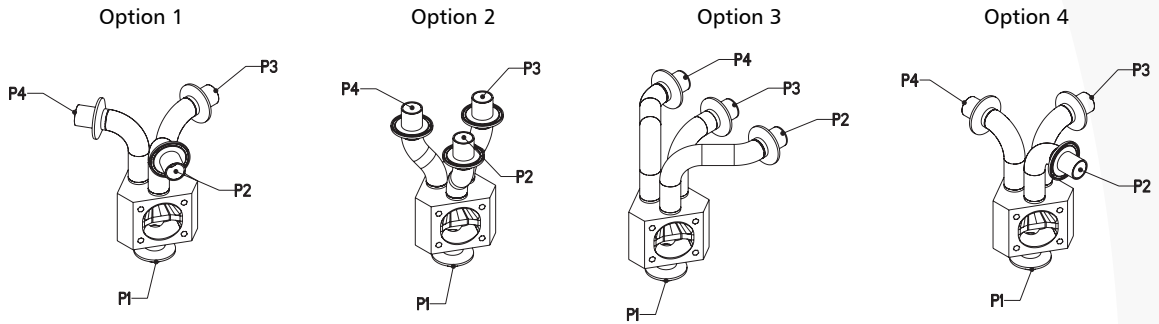

4-Way

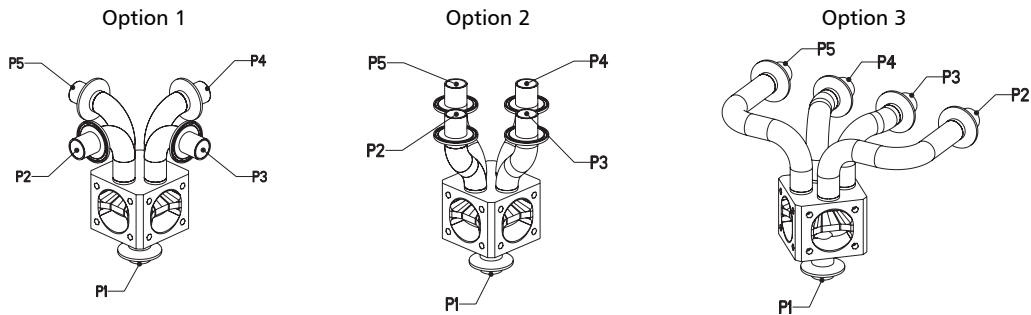

5-Way

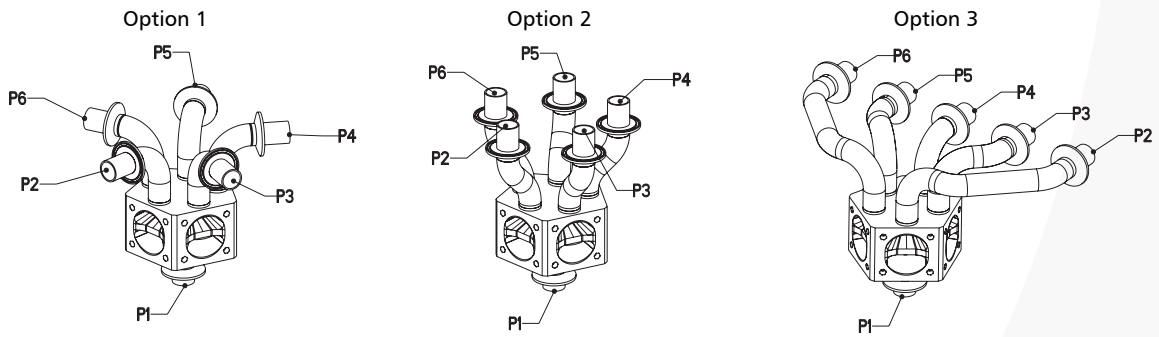

6-Way

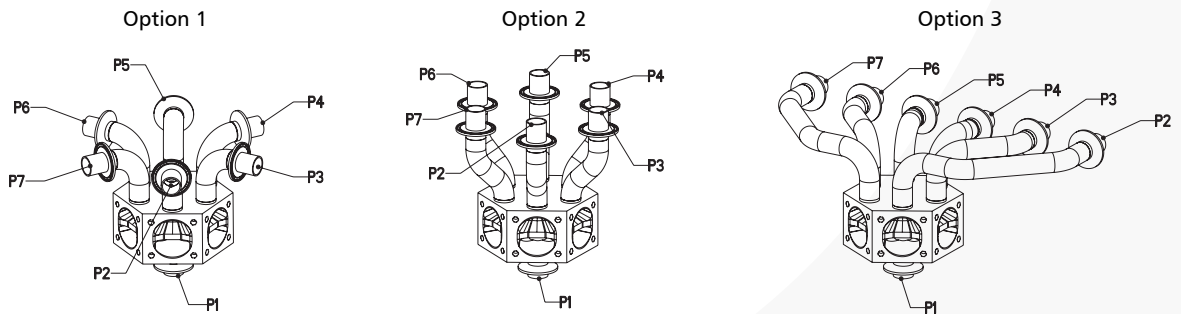

# Sterile Tank Vent Filter Shunt (DV2WS)

Sterile Tank Vent Filter Shunt with a 1.5" wrought stainless steel body, inlet and outlets have Tri-Clamp ends, outlet is Option 2, 25 Ra interior finish, standard exterior finish (Scotch Brite).

Figure Number: DV2WS-1.5-419-W-6-1-0

Valve Body	Configuration Example	DV2WS	1.5		419	W	6-1-0
	Block Type	DV2WS					
	Valve Size <sup>1</sup>		1.5				
	Common Port Size (P1) <sup>2</sup>						
	End Connections				419		
	Body Material					W	
	Polish Selections						6-1-0

<sup>1</sup> Standard sizes: 1.5" and 2"

<sup>2</sup> Common Port Size option provides increased clamp size to connect directly to an available tank port.

Valve Size: 1.5" and 2"

Optional Common Port Size for 1.5: 2", 2.5", 3", 4"

Optional Common Port Size for 2: 2.5", 3", 4"

Consult the factory for non-jacketed versions available for use with electric heaters.

To add topworks, see page 38.

DV2WS - 1.5" valve size

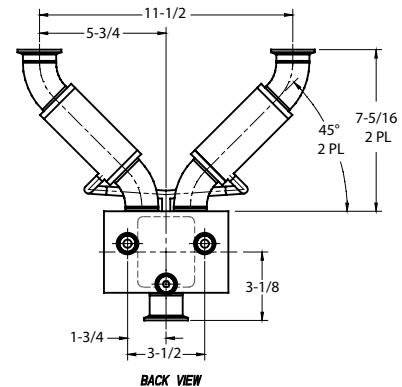
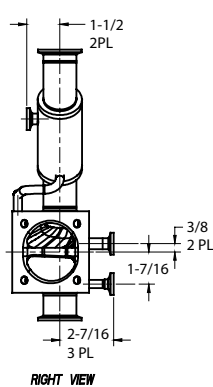
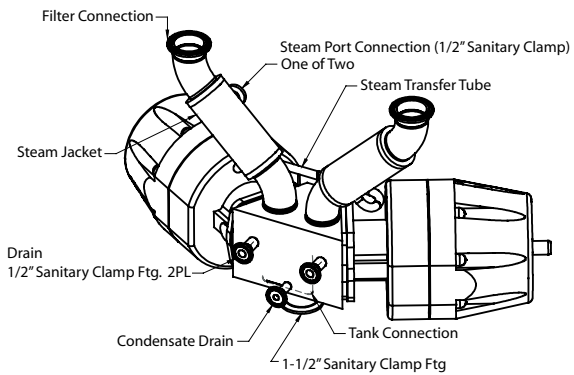
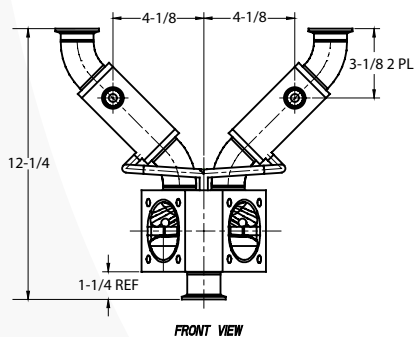
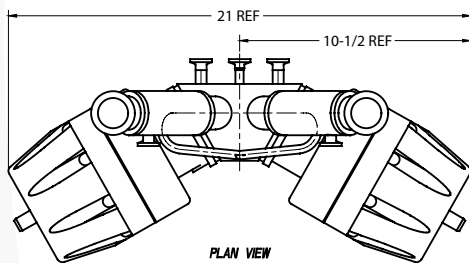

Please contact the factory for the latest drawing and dimensional information. The above drawing should only be used as a general reference.

# Horizontal Divert Valve 3-Way (HDV3W)

2" Horizontal Divert Valve 3-Way, wrought stainless steel body, butt weld end, common port (P1) on the right (when facing the weir of the third valve), 25 Ra interior finish, standard exterior finish (Scotch Brite).

Figure Number: HDV3W-2-428-R-W-6-1-0

Main Valve	Configuration Example	HDV3W	2	428	R	W	6-1-0
	Block Type	HDV3W					
	Valve Size		2				
	Type (.5" only) <sup>1</sup>						
	Valve End Connections (P1 - P4) <sup>2</sup>			428			
	Valve Orientation <sup>3</sup>				R		
	Body Material					W	
	Polish Selections						6-1-0

<sup>1</sup> For .5 inch valve, must specify Pure-Flo (PF) or Bio-Tek (BT).

<sup>2</sup> Contact the factory for discrete end connection options.

<sup>3</sup> This determines which side (right or left) the Common Port (P1) is on when viewing the top (See plan view below).

To add topworks, see page 38.

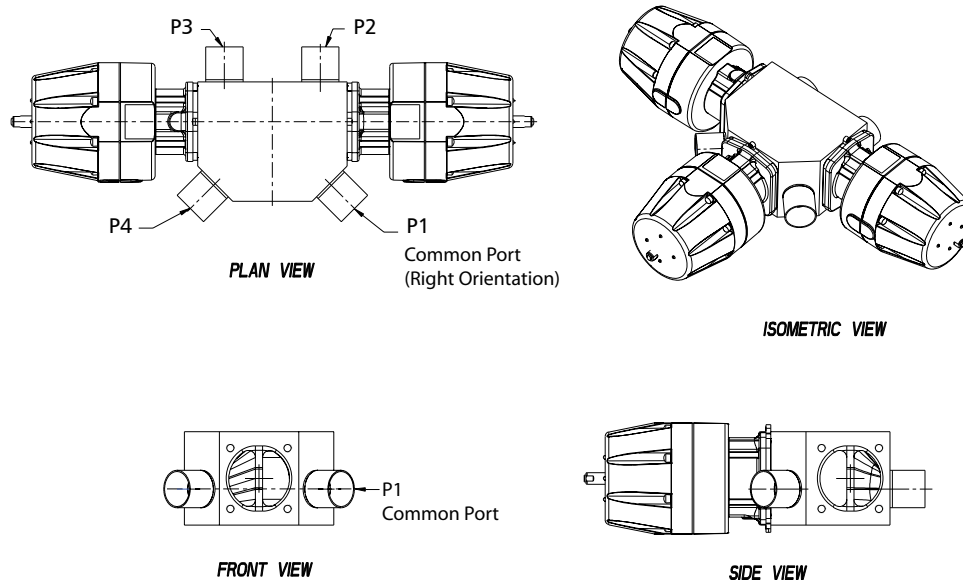

Please contact the factory for the latest drawing and dimensional information. The above drawing should only be used as a general reference.

# Integral Dual Sterile Access (IDSA)

3" Integral Dual Sterile Access, wrought stainless steel, Tri-Clamp ends, 2" Second valve (P1 side) is oriented down, 2" Third valve (P2 side) is oriented down, 25 Ra interior finish, standard exterior finish (Scotch Brite).

Figure Number: IDSA-3-419-2-2-W-6-1-0

Valve Body	Configuration Example	IDSA	3	419	2				2				W	6-1-0
	Block Type	IDSA												
	Main Valve Size		3											
	Main Valve End Connections (P1, P2)			419										
	Second Valve Size				2									
	Second Valve Type (.5" only) <sup>1</sup>													
	Second Valve End Connection (P3) <sup>2</sup>													
	Second Valve Orientation													
	Third Valve Size					2								
	Third Valve Type (.5" only) <sup>1</sup>													
	Third Valve End Connection (P4) <sup>2</sup>													
	Third Valve Orientation													
	Body Material												W	
	Polish Selections													6-1-0

<sup>1</sup> For .5 inch valve, must specify Pure-Flo (PF), Bio-Pure (BP) or Bio-Tek (BT).

<sup>2</sup> Specify second (P3) and third (P4) end connections if they differ from those for the main valve (P1, P2). To add topworks, see page 38.

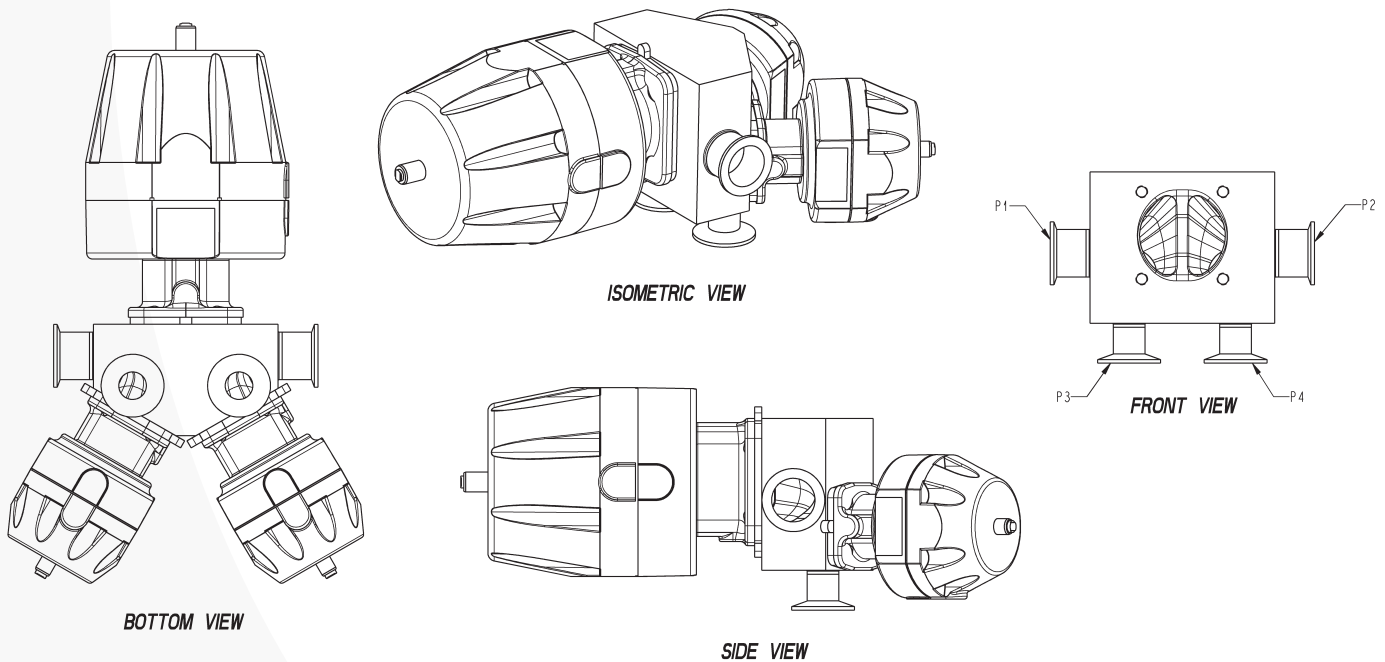

Please contact the factory for the latest drawing and dimensional information. The above drawing should only be used as a general reference.

# Integral Horizontal Sterile Access (IHSA)

Integral Horizontal Sterile Access valve with a 1" wrought stainless steel body, all outlets have butt weld ends, 25 Ra interior finish, standard exterior finish (Scotch Brite).

Figure Number: IHSA-1-428-1-428-W-6-1-0

Valve Body	Configuration Example	IHSA	1	428	1	428	W	6-1-0
	Block Type	IHSA						
	Valve Size		1					
	Type (.5" only) <sup>1</sup>							
	End Connections (P1, P2)			428				
	Second Valve Size				1			
	Second Valve Type (.5" only) <sup>1</sup>							
	Second Valve End Connection (P3)					428		
	Body Material						W	
	Polish Selections							6-1-0

<sup>1</sup> For .5 inch valve, must specify Pure-Flo (PF) or Bio-Tek (BT)  
To add topworks, see page 38.

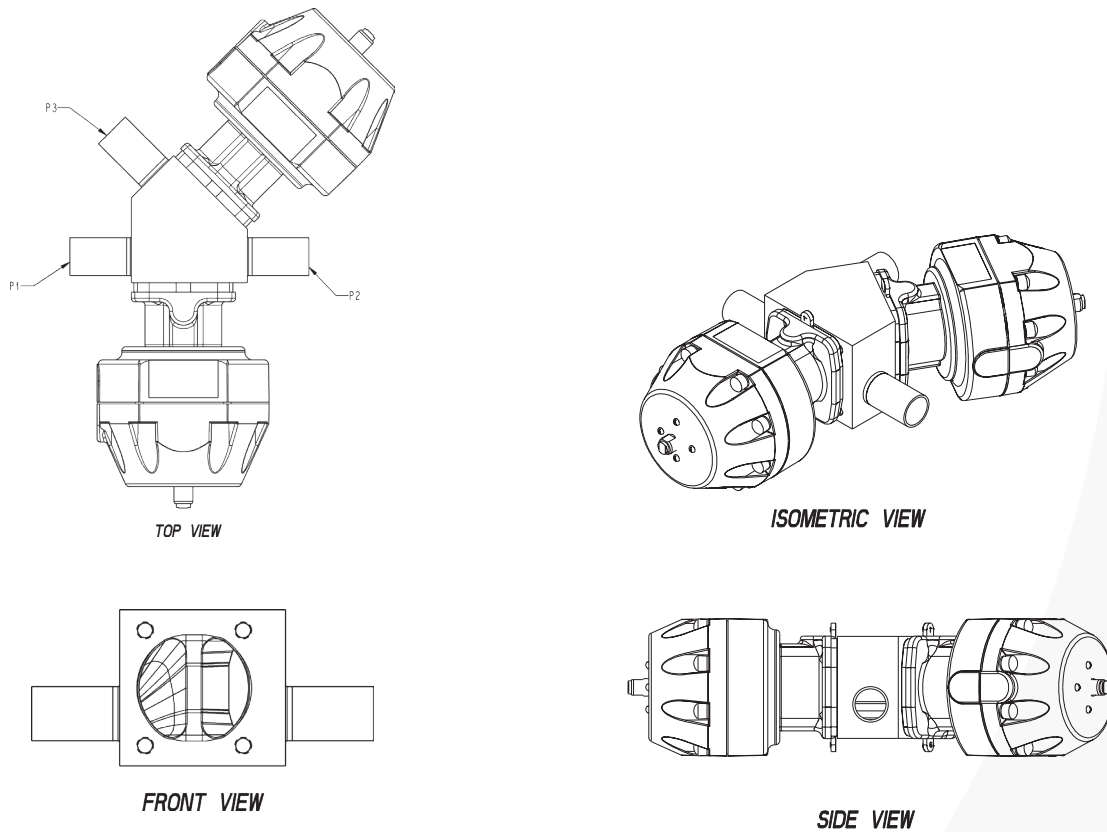

Please contact the factory for the latest drawing and dimensional information. The above drawing should only be used as a general reference.

# How to Order an ISG

Integral Sterile Access and GMP valve with a 1.5" wrought stainless steel body, inlets and outlets on the main valve (P1 and P2) are sanitary clamp with a buttweld end, second valve is an end connection option 2, second valve is a .5" Pure-Flo, 25 Ra interior finish, standard exterior finish (Scotch Brite).

Figure Number: ISG-1.5-2-.5-SVPF-R-W-6-1-0

Valve Body	Configuration Example	ISG	1.5	2	.5	SVPF	R	W	6-1-0
	Block Type	ISG							
	Valve Size (Main)		1.5						
	Type (.5" only) <sup>1</sup>								
	Outlet Option			2					
	Second Valve Size				.5				
	Second Valve Type (.5" only) <sup>1</sup>					SVPF			
	Valve Orientation <sup>2</sup>						R		
	Body Material							W	
	Polish Selections								6-1-0

<sup>1</sup> For .5 inch valve, must specify Pure-Flo (PF), Bio-Pure (BP) or Bio-Tek (BT)

<sup>2</sup> Second valve ported on the left or right side of main valve weir.  
To add topworks, see page 38.

## End Connection Options

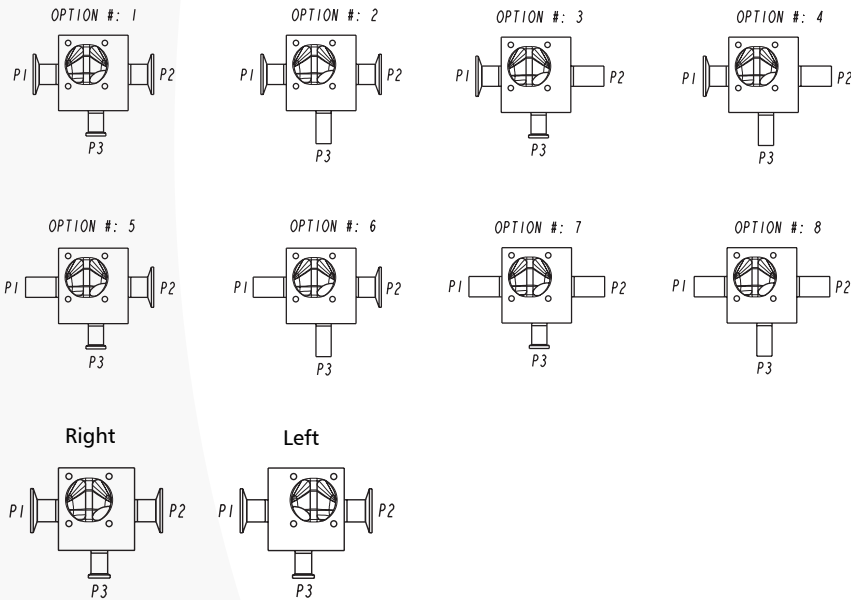

# How to Order a Sterile Barrier

1" Integral Sterile Barrier, wrought stainless steel, Tri-Clamp end connections, 25 Ra interior finish, standard exterior finish (Scotch Brite).

Figure Number: SB1-1-419-W-6-1-0

Valve Body	Configuration Example	SB1	1		419	W	6-1-0
	Block Type	SB1					
	Process Valve Size		1				
	Type (.5" only) <sup>1</sup>						
	Body End Connections (P1-P4) <sup>2</sup>				419		
	Body Material					W	
	Polish Selections						6-1-0

<sup>1</sup> For .5 inch valve, must specify Pure-Flo (PF), Bio-Pure (BP) or Bio-Tek (BT)

<sup>2</sup> Second valve ported on the left or right side of main valve weir.

To add topworks, see page 38.

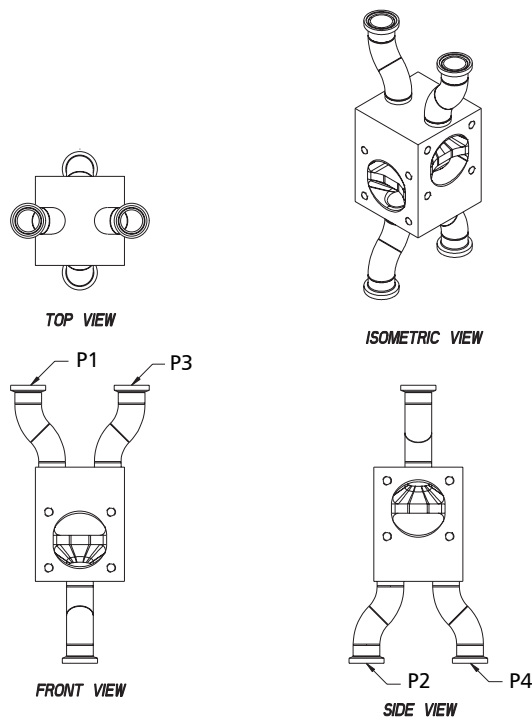

Please contact the factory for the latest drawing and dimensional information. The above drawing should only be used as a general reference.

# How to Order Topworks for Block Body Valves

## Manual Topworks

1.5" 963 manual bonnet (plastic PAS rising handwheel with travel stop) with no valve body, E1 diaphragm, viton seal, PPS cap.

Figure Number: 1.5-N-E1-963

Manual Bonnets & Accessories	Configuration Example	1.5	N	E1	963															
	Valve Size	1.5																		
	Body (Not Supplied)		N																	
	Diaphragm			E1																
	Manual Bonnets				963															
	Weep Holes																			
	Electropolish Topworks																			
	Optional Coatings																			
	Bonnet Seal Materials																			
	Optional Bonnet Internals <sup>1</sup>																			
	Optional Body/Bonnet Bolting																			
	Yoke																			
	Locking Device																			
	Extended Stem																			

<sup>1</sup> Multiple selections allowed

## Actuated Topworks

.5" Advantage 2.1 Actuator (reverse acting # 8 with 90# spring) with stainless steel bonnet and no valve body, E1 diaphragm, Stainless Steel compressor.

Figure Number: .5-N-E1-31-B209

Actuated Bonnets & Accessories	Configuration Example	.5	N	E1	31															B209	
	Valve Size	.5																			
	Body (Not Supplied)		N																		
	Diaphragm			E1																	
	Actuated Bonnets				31																
	Weep Holes																				
	Electropolish Topworks																				
	Optional Coatings																				
	Bonnet Seal Materials																				
	Optional Bonnet Internals <sup>1</sup>																				
	Optional Body/Bonnet Bolting																				
	Yoke																				
	Locking Device																				
	Extended Stem																				
Actuator Options																				B209	

<sup>1</sup> Multiple selections allowed

Example of a complete figure number for block body valve and topworks:

ISG-1.5-2-.5-SVPPF-R-W-6-1-0

1.5-N-E1-963-

.5-N-E1-31-B209

# EnviZion Valve Ordering Guide



# EnviZion Valve Ordering Guide

## How to Construct an EnviZion Valve Figure Number

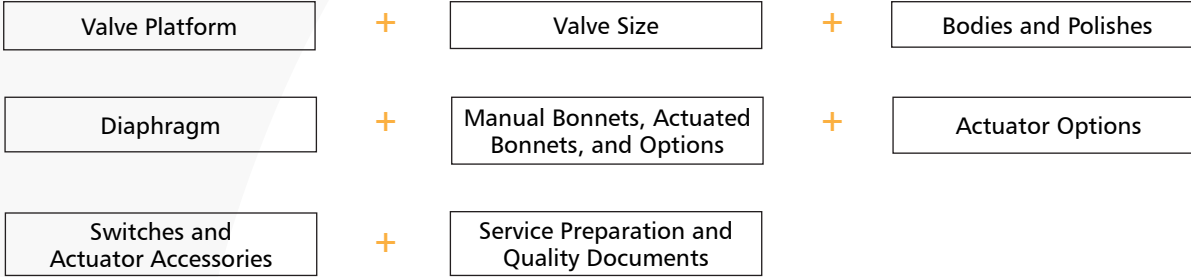

### Constructing Figure Numbers

Below are examples for constructing a manual and actuated valve figure number. The actuated valve example will be used to build a figure number on the following pages.

#### Figure Number Example - Manual Valve

**Figure Number:** ENV-1-F-419-6-0-0-TMZ-ZH

Detailed description:

- 1: 1 inch size (DN25)
- F: Forged 316L SS
- 419: Triclamp Tube
- 6: Interior Finish: Ra 25 Microinch Max
- 0: Exterior Finish: No Mechanical Polish
- 0: No Electropolish
- TMZ: Modified PTFE Diaphragm (FDA)/ Grade B1 B.C.
- ZH: EnviZion zero torque handwheel

#### Valve Platform

Platform	
Code	Description
ENV	EnviZion valve

#### Valve Size

Size	
Code	Description
.50	.50 Inch (DN15)
.75	.75 Inch (DN20)
.75R	.75 Inch (DN20) with 0.5" topworks
1	1 Inch (DN25)
1.5	1.5 inch (DN40)
2	2.0 inch (DN50)

#### Figure Number Example - Actuated Valve

**Figure Number:** ENV-1-F-428L-6-0-0-TMZ-ZA1-ISP-3W-HZ

Detailed description:

- 1: 1 inch size (DN25)
- F: Forged 316L SS
- 428L: 16 Gauge Extended Tangent Butt weld
- 6: Interior Finish: Ra 25 Microinch Max
- 0: Exterior Finish: No Mechanical Polish
- 0: No Electropolish
- TMZ: Modified PTFE Diaphragm (FDA)/ Grade B1 B.C.
- ZA1: EnviZion zero torque actuator - fail open
- ISP: 3W - 3 Wire Output
- ISP: NSV - No Solenoid
- ISP: ST - Standard Cover
- ISP: NBT - No Diagnostics
- ISP: HZ - Hazardous Location Class I, II, III; DIV 2

**Figure Number:** ENV-1

Configuration Example	ENV	1
Valve Platform	ENV	
Valve Size		1

# EnviZion Valve Ordering Guide

## Bodies and Polishes

### Body Type

Code	Description
F	Forged 316L Stainless Steel
N	Body Not Supplied
TBV	Tank Bottom Valve
TBVCR	Tank Bottom Valve 316L BN2
W	Wrought 316L Stainless Steel
Spec	Special Material Body

### Body Ends

Code	Description
<b>Clamp</b>	
409	Swagelok TS Fitting
410	Tri-Clamp Sch. 5 Pipe
418	ISO 1.6mm Wall Tri-Clamp End
419	Tri-Clamp Tube
419S	Tri-Clamp Tube 18 Gauge
419S1	Tri-Clamp Tube 20 Gauge
<b>Buttweld</b>	
422	Sch. 5 Pipe (ISO Body)
423	18 Gauge
424	20 Gauge
425	Sch. 5 Pipe (ANSI Body)
426	Sch. 10 Pipe
428	16 Gauge
428L	16 Gauge Ext. Tangent BW
481	DIN Series 1
482	DIN Series 2
483	DIN Series 3
484	SMS
485	TBV, 45 Degree 14 GA BW
486	TBV, 45 Degree 16 GA BW
487	TBV, 45 Degree 18 GA BW
488	TBV, 45 Degree Tri-Clamp
493	ISO 2.9mm wall
494	ISO 1.2mm wall
495	ISO 1.0mm wall
496	ISO 1.6mm wall
497	ISO 2.0mm wall
498	ISO 2.3mm wall
499	ISO 2.6mm wall
Spec	Special End

### Second End Code

Code	Description
<b>Clamp</b>	
X07	By Male Thread w/ Gasket Seat
X09	Swagelok TS Fitting
X10	By Tri-Clamp Sch. 5 Pipe
X19	By Tri-Clamp Tube
X19S	By Tri-Clamp Tube 18 Gauge
X19S1	By Tri-Clamp Tube 20 Gauge
<b>Buttweld</b>	
X22	By Sch. 5 Pipe (ISO Body)
X23	By 18 Gauge
X24	By 20 Gauge
X25	By Sch. 5 Pipe (ANSI Body)
X26	By Sch. 10 Pipe
X27	By Sch. 40 Pipe
X28	By 16 Gauge
X28L	By 16 Gauge Ext. Tangent BW
X81	By DIN Series 1
X82	By DIN Series 2
X83	By DIN Series 3
X84	By SMS
X85	By ISO
X93	By ISO 2.9mm Wall
X94	By ISO 1.2mm Wall
X95	By ISO 1.0mm Wall
X96	By ISO 1.6mm Wall
X97	By ISO 2.0mm Wall
X98	By ISO 2.3mm Wall
X99	By ISO 2.6mm Wall
Spec	Special End

### Tube Extension

Code	Description
TE1	Valve End 1
TE2	Valve End 2
TEA	Both Valve Ends & Purge End
TEB	Both Valve Ends
TEP	Purge End
TE1P	Valve End (P1) & Purge (P3)
TE2P	Valve End (P2) & Purge (P3)

### Mechanical Polish - Interior

Code	Description
6	25 $\mu$ m Ra (.6 $\mu$ m) max
7	15 $\mu$ m Ra (.38 $\mu$ m) max
8	20 $\mu$ m Ra (.5 $\mu$ m) max
10	10 $\mu$ m Ra (.25 $\mu$ m) max
SF1	BPE SF1 Ra 20 Max
SF2	BPE SF2 Ra 25 Max
SF3	BPE SF3 Ra 30 Max
SF4	BPE SF4 Ra 15 Max, EP
SF5	BPE SF5 Ra 20 Max, EP
SF6	BPE SF6 Ra 25 Max, EP

### Mechanical Polish - Exterior

Code	Description
0	No Mechanical Polish
1	Scotch Brite
2	25 $\mu$ m Ra (.6 $\mu$ m) max, Welds Scotch Brite
3	35 $\mu$ m Ra (.8 $\mu$ m) max, Welds Scotch Brite
4	25 $\mu$ m Ra (.6 $\mu$ m) max, Welds Removed
6	35 $\mu$ m Ra (.8 $\mu$ m) max, Welds Removed
7	Special Polish Requirement
8	No Ext Body Polish, Weld Beads Removed

### Electropolish

Code	Description
0	No Electropolish
2	Exterior Only
3	Interior and Exterior
4	Interior Only

### Body Only

Code	Description
Y	Body Only Supplied

Figure Number: ENV-1-F-428L-6-0-0-

Configuration Example		F	428L			6	0	0	
Bodies and Polishes	Block Type	F							
	Body Ends		428L						
	Second End Code								
	Tube Extension								
	Mechanical Polish - Interior					6			
	Mechanical Polish - Exterior							0	
	Electropolish								0
	Body Only								

# EnviZion Valve Ordering Guide

## Diaphragms

### Diaphragms

Code	Description
TMZ	PTFE (FDA) Grade B1 B.C.

Figure Number: ENV-1 -F-428L-6-0-0-TMZ-

Configuration Example	TMZ
Diaphragm	TMZ

## Manual Bonnets

### Manual Bonnets

Code	Description
ZH	EnviZion Manual
ZHS	EnviZion Manual sealed

## Actuated Bonnets and Options

### Actuated Bonnets

Code	Description
ZA1	EnviZion SS Actuator - FO
ZA2	EnviZion SS Actuator - FC (90#)
ZA3	EnviZion SS Actuator - DA
ZA1S	EnviZion SS Actuator - FO sealed
ZA2S	EnviZion SS Actuator - FC (90#) sealed
ZA3S	EnviZion SS Actuator - DA sealed
ZB1	EnviZion Advantage Actuator - FO
ZB2	EnviZion Advantage Actuator - FC (90#)
ZB26	EnviZion Advantage Actuator - FC (60#)
ZB3	EnviZion Advantage Actuator - DA
ZB1S	EnviZion Advantage Actuator - FO sealed
ZB2S	EnviZion Advantage Actuator - FC (90#) sealed
ZB26S	EnviZion Advantage Actuator - FC (60#) sealed
ZB3S	EnviZion Advantage Actuator - DA sealed

### EnviZion Topwork options

Code	Description
EBG	Bonnet Guard – Tamper resistant/submersible

### Electropolish Topworks

Code	Description
1	Topworks

Figure Number: ENV-1-F-428L-6-0-0-TMZ-ZA1

Configuration Example		ZA1		
Bonnets	Manual Bonnets	ZA1		
	Actuated Bonnets			
	Weep Holes			
	Electropolish Topworks			

## Switches and Actuator Accessories

### Integrated Switch Package

Code	Description
ISP-3W-HZ	3 Wire Discrete, without solenoid, without diagnostics
ISP-3W-BL-HZ	3 Wire Discrete, without solenoid, with diagnostics
ISP-3W-LS-HZ	3 Wire Discrete, without solenoid, without diagnostics
ISP-3W-LS-BL-HZ	3 Wire Discrete, without solenoid, with diagnostics
ISP-3W-SV-HZ	3 Wire Discrete, with internal solenoid, without diagnostics
ISP-3W-SV-BL-HZ	3 Wire Discrete, with internal solenoid, with diagnostics
ISP-3W-SV-BT-HZ	3 Wire Discrete, with internal solenoid, with diagnostics and control
ISP-3W-SV-LS-HZ	3 Wire Discrete, with internal solenoid, without diagnostics
ISP-3W-SV-LS-BL-HZ	3 Wire Discrete, with internal solenoid, with diagnostics
ISP-3W-SV-LS-BT-HZ	3 Wire Discrete, with internal solenoid, with diagnostics and control
ISP-AI-HZ	ASi, without solenoid, without diagnostics
ISP-AI-BL-HZ	ASi, without solenoid, with diagnostics
ISP-AI-LS-HZ	ASi, without solenoid, without diagnostics
ISP-AI-LS-BL-HZ	ASi, without solenoid, with diagnostics
ISP-AI-SV-HZ	ASi, with internal solenoid, without diagnostics
ISP-AI-SV-BL-HZ	ASi, with internal solenoid, with diagnostics
ISP-AI-SV-BT-HZ	ASi, with internal solenoid, with diagnostics and control
ISP-AI-SV-LS-HZ	ASi, with internal solenoid, without diagnostics
ISP-AI-SV-LS-BL-HZ	ASi, with internal solenoid, with diagnostics
ISP-AI-SV-LS-BT-HZ	ASi, with internal solenoid, with diagnostics and control
ISP-2W	2 Wire, without solenoid, without diagnostics
ISP-2W-LS	2 Wire, without solenoid, without diagnostics
ISP-2W-SV	2 Wire, with internal solenoid, without diagnostics
ISP-2W-SV-LS	2 Wire, with internal solenoid, without diagnostics
ISP-DN-HZ	DeviceNet, without solenoid, without diagnostics
ISP-DN-BL-HZ	DeviceNet, without solenoid, with diagnostics
ISP-DN-LS-HZ	DeviceNet, without solenoid, without diagnostics
ISP-DN-LS-BL-HZ	DeviceNet, without solenoid, with diagnostics
ISP-DN-SV-HZ	DeviceNet, with internal solenoid, without diagnostics
ISP-DN-SV-BL-HZ	DeviceNet, with internal solenoid, with diagnostics
ISP-DN-SV-BT-HZ	DeviceNet, with internal solenoid, with diagnostics and control
ISP-DN-SV-LS-HZ	DeviceNet, with internal solenoid, without diagnostics
ISP-DN-SV-LS-BL-HZ	DeviceNet, with internal solenoid, with diagnostics
ISP-DN-SV-LS-BT-HZ	DeviceNet, with internal solenoid, with diagnostics and control

### Value Switch Package

Code	Description
VSPG30	Gold Contacts 30V
VSPN	NAMUR Proximity
VSP3	3-Wire PNP Proximity
VSPS48	Silver Contacts 48V
VSPZ	2-Wire Proximity
VSP+G	Gold Contacts 24V
VSP+S	Silver Contacts 24V
VSP+N	NAMUR Proximity 24V
VSP+Z	2-Wire Proximity 24V
VSP+P	3 wire PNP Proximity
VSPS240	Silver Contacts 240V

# EnviZion Valve Ordering Guide

## Switches and Actuator Accessories (cont.)

### Limit Switches

Code	Description
LS13	Westlock 9880
LS14	Westlock E9880
LS128	Westlock 99P21A00000
LS129	Westlock 99P21AD550
LS168	STONEL PI33S11SA01RSA
LS 173	STONEL PI92S11SA15RSA
LS 179	STONEL PI92S1KSA15RSA
LSSpec	Special

### Solenoid Valve

Code	Description
SV1	Asco 8320G184
SV2	Asco EF8320G184
SV3	Asco 8345G1
SV4	Asco EF8345G1
SV7	Asco 8302G202
SV8	Asco EF8320G202
SV14	Burkert Series 6012
SV15	Burkert Series 6014

### Positioners

Code	Description
PR16	PR16 YTC TMP 3000
PRSpec	Special

Figure Number: ENV-1-F-428L-6-0-0-TMZ-ZA1-ISP-3W-HZ

Switches and Actuator Accessories	Configuration Example	ISP-3W-HZ											
Switch Packages (select 1):	ISP	ISP-3W-HZ											
Limit Switches - Special													
Mechanical Accessories													
Actuator Hardware Options													
Solenoid Valve													
Solenoid Voltage													
Speed Controllers													
Filter Regulators													
Positioners													

## Service Preparation and Quality Documents

### Special Service Preparation

Code	Description
BAG	Cleaned and Bagged
EU_SERVICE	European Union Service
OXY	Oxygen
SIFREE	Silicone Free Preparation
SPEC	Customer Special
VAC	Vacuum

### Special Quality Documents

Code	Description
SQD2	C of C (seat & shell pressures)
SQD3	C of C Profilometer Tape for each body
SQD5	C of C Body/Stud/Nut CMTR and C of C to ASME Section VIII
SQD6	C of C Tube CMTR, Tank Bottom Valve
SQD7	C of C Weld Rod CMTR, Tank Bottom Valve

Figure Number: ENV-1-F-428L-6-0-0-TMZ-ZA2-ISP-3W-HZ-SQD3

Configuration Example		SQD3
Special Service Preparation		
Special Quality Documents		SQD3

Block Body valves are available for EnviZion. Go to our website (<https://www.engvalves.com/en-US/Tools-and-Resources/Product-Drawings/Pure-Flo-Drawings/EnviZion-Valve-Drawings/>) for more information. Others available upon request.

Visit our website at

[www.engvalves.com](http://www.engvalves.com)



ITT Engineered Valves  
33 Centerville Road  
Lancaster, PA 17603, USA  
Tel: +1 (717) 509-2200

Cam-Line, Cam-Tite, Dia-Flo,  
EnviZion, Pure-Flo, Skotch

ITT Engineered Valves  
1110 Bankhead Avenue  
Amory, MS 38821, USA  
Tel: +1 (662) 256-7185

Fabri-Valve

ITT Bornemann GmbH  
31683 Obernkirchen  
Germany  
Tel: +49 5724 390-0

EnviZion, Pure-Flo