

S200 Series

CENTRIFUGAL PUMP

FORM NO.: 95-03080 REVISION: 12/2010

READ AND UNDERSTAND THIS MANUAL PRIOR TO OPERATING OR SERVICING THIS PRODUCT.



Triplex Sales
1-847-839-8442
www.triplexsales.com

Triplex Sales
1-847-839-8442
www.triplexsales.com

SPX Flow Technology
611 Sugar Creek Road
Delavan, WI 53115 USA

Tel: (800) 252-5200 or (262) 728-1900
Fax: (800) 252-5012 or (262) 728-4904

E-mail: wcb@spx.com
Web site: www.spx.com

Information contained in this manual is subject to change without notice and does not represent a commitment on the part of SPX Corporation. No part of this manual may be reproduced or transmitted in any form or by any means, electronic or mechanical, including photocopying and recording, for any purpose, without the express written permission of SPX Corporation.

Copyright © 2005, 2010 SPX Corporation.
All Rights Reserved.

Revision Date: 12/2010

Publication: 95-03080



Warranty	6
Shipping Damage or Loss	6
Warranty Claim	6
Safety	7
Care of Stainless Steel	8
Stainless Steel Corrosion	8
Elastomer Seal Replacement Following Passivation	8
Introduction	9
Factory Inspection	9
Receiving Your Pump	9
Receiving and Inspection	9
Pump Characteristics	10
S200 Series Base Mount Description	10
Base Mount Components	10
Motor Adapter	11
Stand	11
Base (Optional)	11
Performance Characteristics	13
Authorization	13
Standard Construction	13
Construction Options	13
Operating Parameters	14
Installation	23
Pump Location	23
Pump Leveling	23
Supply and Discharge Piping/Valves	23
Installations That May Cause Operation Problems	25
Electrical Connections	25
Flush Seal Option	26
Type 4 Seal (Double mechanical with flush)	26
Before First Startup	26
Clean Pump and Piping	26
Cleaning Safety Procedures	27
Manual Cleaning	27
Cleaning-In-Place (CIP)	27
Preliminary Test Run	27
Ammeter Test	27
Operation	28
Starting the Pump	28
Priming the Pump	28
Priming the Pump With the Feed Source Above Pump Level	28
Priming the Pump With the Feed Source Below Pump Level	29
Stopping the Pump	29
Maintenance	30
Scheduled Maintenance	30
Routine Maintenance	30
Pump Disassembly with Type 1 Seal	30
Removal of the Water Cascade	30



Inspect Parts	32
Pump Assembly with Type 1 Seal	33
Backplate Assembly	33
Backplate/Impeller Assembly	33
Pump Disassembly with Type 4 Double Seal	35
Removal of the Water Cascade	36
Pump Assembly with Type 4 Double Seal	38
Disassembly of Modular Base Mounted Pumps	40
Disassembling The Outer Seal Assemblies	42
Assembling the Outer Seal Assemblies	42
Pre-assembled (Cartridge) Seals	43
Disassembly of Pre-assembled (Cartridge) Seals	43
Assembly of a Pump With Pre-assembled (Cartridge) Seals	44
Pedestal Base Mounted Pump Housing Lubrication	46
Lubrication Schedule	46
Servicing the Electric Motor	46
General Service Information	46
Motor Lubrication Instructions	46
Standard Seal Dimensions	47
Cartridge Seal Dimensions	48
Parts Lists	49
Seal Kits	49
Basic Seal Kit - Type 1 Seal - Sanitary Pump Model	49
Complete Seal Kit - Type 1 Seal - Sanitary Pump Model	49
Basic Seal Kit - Type 4 Seal - Sanitary Pump Model	50
Complete Seal Kit - Type 4 Seal - Sanitary Pump Model	50
Class VI Elastomer Kits	51
Motor Shaft Shims	51
Seal Components All Pumps	52
S2045 Components (Close Coupled)	54
S2065/S2065LV/S2065HV Components (Close Coupled)	56
S2075 Components (Close Coupled)	58
S2085/2085LV Components (Close Coupled)	60
S2092 Components (Close Coupled)	62
Pedestal Mounted Pumps - Small Bore	64
Pedestal Mounted Pumps - Large Bore	68
Motor Mounts	72
Troubleshooting	73

Warranty

Seller warrants its products to be free from defect in materials and workmanship for a period of one (1) year from the date of shipment. This warranty shall not apply to products which require repair or replacement due to normal wear and tear or to products which are subjected to accident, misuse or improper maintenance. This warranty extends only to the original Buyer. Products manufactured by others but furnished by Seller are exempted from this warranty and are limited to the original manufacturer's warranty.

Seller's sole obligation under this warranty shall be to repair or replace any products that Seller determines, in its discretion, to be defective. Seller reserves the right either to inspect the products in the field or to request their prepaid return to Seller. Seller shall not be responsible for any transportation charges, duty, taxes, freight, labor or other costs. The cost of removing and/or installing products which have been repaired or replaced shall be at Buyer's expense.

Seller expressly disclaims all other warranties, express or implied, including without limitation any warranty of merchantability of fitness for a particular purpose. The foregoing sets forth Seller's entire and exclusive liability, and Buyer's exclusive and sole remedy, for any claim of damages in connection with the sale of products. In no event shall Seller be liable for any special consequential incidental or indirect damages (including without limitation attorney's fees and expenses), nor shall Seller be liable for any loss of profit or material arising out of or relating to the sale or operation of the products based on contract, tort (including negligence), strict liability or otherwise.

Shipping Damage or Loss

If equipment is damaged or lost in transit, file a claim at once with the delivering carrier. The carrier has signed the Bill of Lading acknowledging that the shipment has been received from the seller in good condition. Seller is not responsible for the collection of claims or replacement of materials due to transit shortages or damages.

Warranty Claim

Warranty claims must have a **Returned Goods Authorization (RGA)** from the Seller before returns will be accepted.

Claims for shortages or other errors, exclusive of transit shortages or damages, must be made in writing to Seller within ten (10) days after delivery. Failure to give such notice shall constitute acceptance and waiver of all such claims by Buyer.

Safety

READ AND UNDERSTAND THIS MANUAL PRIOR TO INSTALLING, OPERATING OR SERVICING THIS EQUIPMENT

We recommend users of our equipment and designs follow the latest Industrial Safety Standards. At a minimum, these should include the industrial safety requirements established by:

1. Occupational Safety and Health Administration (OSHA), Title 29 of the CFR
Section 1910.212- General Requirements for all Machines
2. National Fire Protection Association, ANSI/NFPA 79
ANSI/NFPA 79- Electrical Standards for Industrial Machinery
3. National Electrical Code, ANSI/NFPA 70
ANSI/NFPA 70- National Electrical Code
ANSI/NFPA 70E- Electrical Safety Requirement for Employee Workplaces
4. American National Standards Institute, Section B11

Attention: Servicing energized industrial equipment can be hazardous. Severe injury or death can result from electrical shock, burn, or unintended actuation of controlled equipment. Recommended practice is to disconnect and lockout industrial equipment from power sources, and release stored energy, if present. Refer to the National Fire Protection Association Standard No. NFPA70E, Part II and (as applicable) OSHA rules for Control of Hazardous Energy Sources (Lockout-Tagout) and OSHA Electrical Safety Related Work Practices, including procedural requirements for:

- Lockout-tagout
- Personnel qualifications and training requirements
- When it is not feasible to de-energize and lockout-tagout electrical circuits and equipment before working on or near exposed circuit parts

Locking and Interlocking Devices: These devices should be checked for proper working condition and capability of performing their intended functions. Make replacements only with the original manufacturer's renewal parts or kits. Adjust or repair in accordance with the manufacturer's instructions.

Periodic Inspection: Industrial equipment should be inspected periodically. Inspection intervals should be based on environmental and operating conditions and adjusted as indicated by experience. At a minimum, an initial inspection within 3 to 4 months after installation is recommended. Inspection of the electrical control systems should meet the recommendations as specified in the National Electrical Manufacturers Association (NEMA) Standard No. ICS 1.3, Preventative Maintenance of Industrial Control and Systems Equipment, for the general guidelines for setting-up a periodic maintenance program.

Replacement Equipment: Use only replacement parts and devices recommended by the manufacturer to maintain the integrity of the equipment. Make sure the parts are properly matched to the equipment series, model, serial number, and revision level of the equipment.

Warnings and cautions are provided in this manual to help avoid serious injury and/or possible damage to equipment:



DANGER: marked with a stop sign.
Immediate hazards which WILL result in severe personal injury or death.



WARNING: marked with a warning triangle.
Hazards or unsafe practices which COULD result in severe personal injury or death.



CAUTION: marked with a warning triangle.
Hazards or unsafe practices which COULD result in minor personal injury or product or property damage.

Care of Stainless Steel

Stainless Steel Corrosion

Corrosion resistance is greatest when a layer of oxide film is formed on the surface of stainless steel. If film is disturbed or destroyed, stainless steel becomes much less resistant to corrosion and may rust, pit or crack.

Corrosion pitting, rusting and stress cracks may occur due to chemical attack. Use only cleaning chemicals specified by a reputable chemical manufacturer for use with 300 series stainless steel. Do not use excessive concentrations, temperatures or exposure times. Avoid contact with highly corrosive acids such as hydrofluoric, hydrochloric or sulfuric. Also avoid prolonged contact with chloride-containing chemicals, especially in presence of acid. If chlorine-based sanitizers are used, such as sodium hypochlorite (bleach), do not exceed concentrations of 150 ppm available chlorine, do not exceed contact time of 20 minutes, and do not exceed temperatures of 104°F (40°C). Corrosion discoloration, deposits or pitting may occur under product deposits or under gaskets. Keep surfaces clean, including those under gaskets or in grooves or tight corners. Clean immediately after use. Do not allow equipment to set idle, exposed to air with accumulated foreign material on the surface. Corrosion pitting may occur when stray electrical currents come in contact with moist stainless steel. Ensure all electrical devices connected to the equipment are correctly grounded.

Elastomer Seal Replacement Following Passivation

Passivation chemicals can damage product contact areas of equipment. Elastomers (rubber components) are most likely to be affected. Always inspect all elastomer seals after passivation is completed. Replace any seals showing signs of chemical attack. Indications may include swelling, cracks, loss of elasticity or any other noticeable changes when compared with new components.

Introduction

Factory Inspection

Each Waukesha pump is shipped completely assembled, lubricated and ready for use. (Make sure you review "Operation" on page 27 before operating your pump).

Receiving Your Pump

All ports are covered at the factory to keep out foreign objects during transit. If the covers are missing or damaged, remove the pump cover and thoroughly inspect the fluid head. Be sure the pumping head is clean and free of foreign material before rotating the shaft.

Receiving and Inspection

1. WCB equipment is inspected prior to shipment. When leaving the factory, it is well-crated for normal transportation procedures. WCB cannot, however, guarantee safe arrival. Therefore, upon receipt of this equipment, check the received items against the packing list for damaged or missing parts. Check the packing material thoroughly for small parts.
2. Visually inspect for damage or loss. Immediately report any damage or loss to the delivery carrier while present. Following the immediate notification of the lost or damaged parts, make a claim against the carrier including a detailed description of the loss or damage, and a cash value. WCB's responsibility terminates F.O.B. point of manufacture unless otherwise specified per the General Terms and Conditions of Sale as published by WCB and amended from time to time. Contact WCB Order Services if shipping information is required for handling claims.

See also "Shipping Damage or Loss" on page 6.

Introduction

Pump Characteristics

The Waukesha S200 Series Pump is built for extremely durable service. The casing, backplate, and impeller/stub shaft are machined from 316L stainless steel for extra strength and resistance to line shock and corrosion. Large bearings and shaft provide positive alignment and minimize vibration.

The casing is clamped to the motor adapter bracket (close coupled) or bearing housing (base mount) for easy disassembly while permitting 360 degree rotation of the discharge port.

S200 Series pumps are available with three standard seal types:

- Type 1 - Single mechanical seal, externally-mounted and balanced
- Type 1C - Single mechanical seal with water cascade flush
- Type 4 - Double mechanical seal with flush housing

All seal components are interchangeable between models. All seal assemblies use an externally-mounted, balanced rotary seal for longer seal life and better sealing capability. The stationary seal face is reversible and replaceable.

S200 Series pumps are designed for a broad range of sanitary and industrial applications. Sanitary models are designed for clean-in-place and meet U.S.D.A. and 3A Standards.

S200 Series Base Mount Description

The Waukesha S200 Series Modular Base Mounted Centrifugal Pump design consists of four components (in addition to the pump and motor). These components are used in various combinations and arrangements to provide flexibility to meet various needs.

Base Mount Components

Bearing Housing (Pump Adapter)

- Bearing housing is made of epoxy-coated cast iron w/316 SS shaft, ball bearings.
- The adapter mounts to the pump components (same components used for close coupled pumps).
- Bearing housing also includes coupling for motor shaft plus guards used in style "B" & "C" arrangements.

Style "B" Arrangement

The style "B" arrangement is composed of the bearing housing, motor adapter and pedestal stand attached to the bearing housing; for use with NEMA C-face motors. All motors must have feet for attachment of supports. See Figure 1.

Style "C" Arrangement

The style "C" arrangement is composed of the bearing housing, guard and pedestal stand attached to the bearing housing; for use with foot mounted T-frame motors. The pump and motor are mounted and supported independently. See Figure 2.

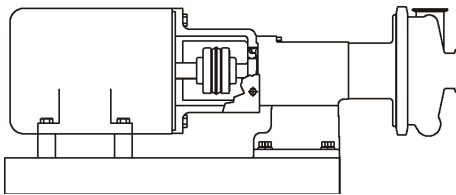

Figure 1 - Style B

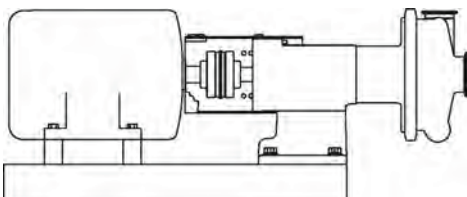

Figure 2 - Style C

Motor Adapter

- Made of epoxy-coated cast iron
- Used to mount a standard NEMA C-face motor onto bearing housing
- Used to provide an accurate, rigid shaft alignment
- Used in style "B" arrangements

Stand

- The stand (pedestal) is made of epoxy-coated cast iron.
- The stand attaches under the motor adapter or bearing housing.

Base (Optional)

- The epoxy-coated channel base is used in style "B" & "C" arrangements. See "Table of Base Size Used on Pedestal-Mounted Centrifugal Pumps" on page 19.

Table 1: Callout Table for Figure 3

A. Motor Shims	H. O-ring
B. Motor Adapter	J. Impeller
C. Lock Washer	K. O-ring
D. Cap Screws	L. Impeller Retainer
E. Seal Guard	M. Clamp
F. Seals (detail not shown)	N. Casing
G. Backplate	

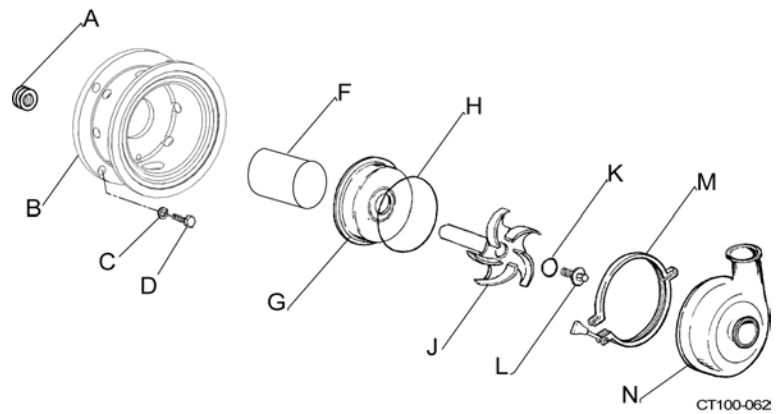

Figure 3 - Common Part Identification

Table 2: Callout Table for Figure 4

A. Motor Shims
B. Deflector
C. Spring Retainer
D. Springs
E. Tabbed Washer
F. O-ring
G. Rotary Seal
H. Cap Screws
J. Seat Retainer
K. Stationary Seal
L. L-gasket
M. Water Cascade Block

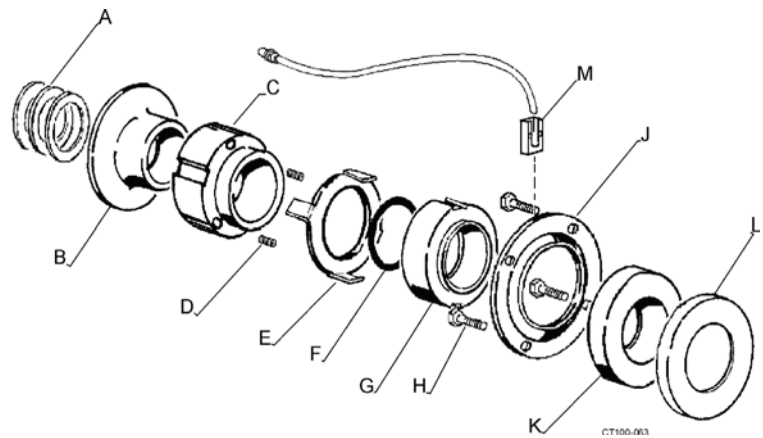

Figure 4 - Common Part Identification

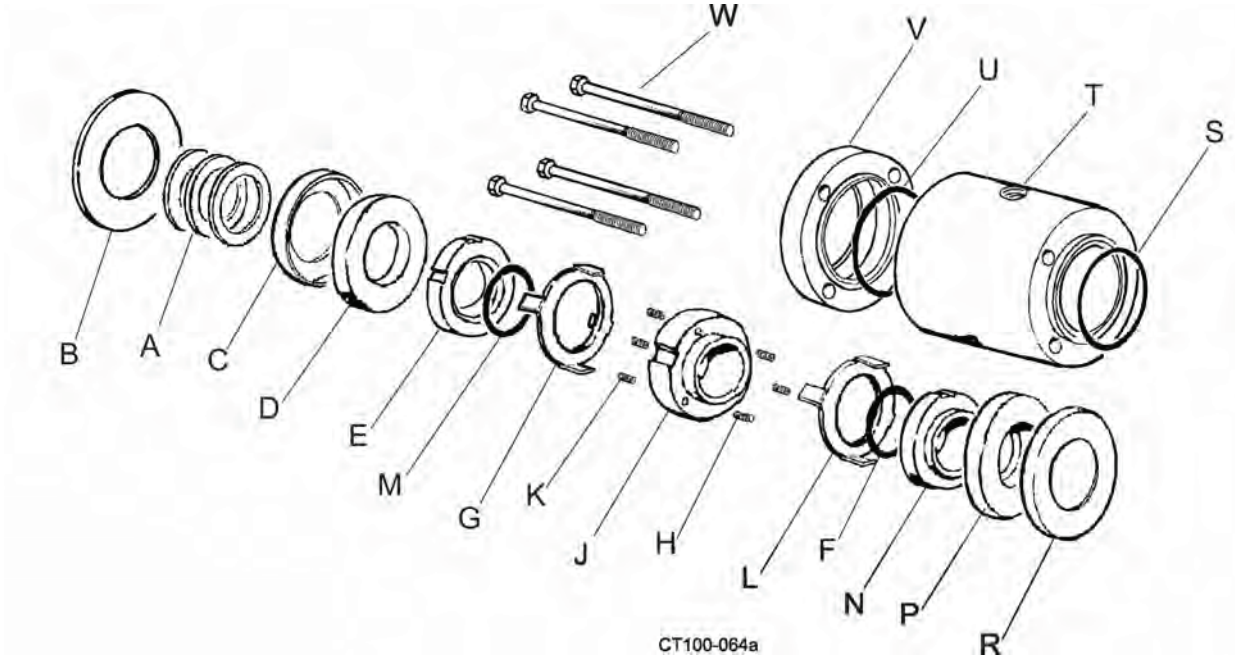

Figure 5 - Common Part Identification

Table 3: Callout Table for Figure 5

A. Motor Shims	L. Tabbed Washer
B. Slinger	M. O-ring
C. L-gasket	N. Rotary Seal
D. Stationary Seal	P. Stationary Seal
E. Rotary Seal	R. L-gasket
F. O-ring	S. O-ring
G. Tabbed Washer	T. Housing
H. Springs	U. O-ring
J. Spring Retainer	V. Seat Retainer
K. Springs	W. Cap Screws

Performance Characteristics

Authorization

3A/USDA (Sanitary Models)

Standard Construction

- Casing: 316L Stainless Steel
- Port Connections: S-Line
- Backplate: 316L Stainless Steel
- Impeller W/Integral Shaft: 316L Stainless Steel
- Impeller Retainer: 316L Stainless Steel
- Shaft Seal: Single Mechanical, externally-balanced (Type 1)
- Rotary Seal Material: Carbon
- Stationary Seal: Purebide
- Elastomers: FDA approved FKM
- Finish: All product contact surfaces provided with a sanitary polish (20Ra mechanical). The motor adapter bracket is Nedox coated cast iron.
- Mounting: Close coupled for JM shafted motors

Construction Options

Ports

Buttweld
Flange 150# MSS
Flange 150# ASA
DIN
DIN Form A
SMS

Seal Type

- Water Cascade (Type 1C)
- Double Mechanical with flush (Type 4 Shaft Seal)
- WFI - Special Type 4 shaft seal for water for injection applications
- Commercially available seals (Contact your WCB representative for details)

Rotary Seal Material

Purebide
Silicone Carbide
Tungsten Carbide

Stationary Seal

Silicone Carbide
Tungsten Carbide

Elastomers

EPDM (FDA approved)
Silicone (FDA approved)
Teflon Encapsulated (FDA approved)
FKM
FFKM

Finishes/Product Contact Surfaces

15RA
20RA
Electropolish

Leg Kit

See "Motor Mounts" on page 72.

Base Mounting

Footed C-face motors
T-Frame motors. **Note:** T-Frame motors can be configured with or without bases, couplings or coupling covers.

Pedestal Mounted

Two types of stands; see "Base Mount Components" on page 10.

Motors

NEMA JM (standard) totally enclosed fan cooled (TEFC) for close-coupled pumps

1750 or 3500 RPM single phase 115/230 volt and 3 phase
230/460 volt

Optional Enclosures

Washdown
Explosion proof
Severe Duty/Chemical Duty

Operating Parameters

Nominal Capacity

Up to 900 U.S. GPM (204 Cubic meters/hour)

Viscosity

Up to 1500 CPS

Differential Pressure

UP to 340 Feet (100 meters)

Temperature

Up to 450°F (230°C)

Nominal Speeds

1450 or 2900 RPM - 50HZ
1750 or 3500 RPM - 60HZ

S200 Series Capacities

Sanitary Model	Inlet Size inch (mm)	Outlet Size inch (mm)	Maximum Capacity GPM (M3/HR)
S2045	1.5 (40)	1.5 (40)	190 GPM (43)
	2.0 (50)	1.5 (40)	190 GPM (43)
S2065LV	1.5 (40)	1.5 (40)	195 GPM (44)
	2.0 (50)	1.5 (40)	195 GPM (44)
	2.5 (65)	1.5 (40)	194 GPM (44)
S2065	2.5 (65)	2.0 (50)	400 GPM (91)
S2065HV	3.0 (75)	2.0 (50)	500 GPM (114)
S2075	3.0 (75)	1.5 (40)	300 GPM (68)
S2085LV	2.0 (50)	1.5 (40)	140 GPM (32)
S2085	3.0 (75)	2.5 (65)	900 GPM (204)
	4.0 (100)	2.5 (65)	900 GPM (204)
S2092	3.0 (75)	2.0 (50)	700 GPM (159)

Dimensions

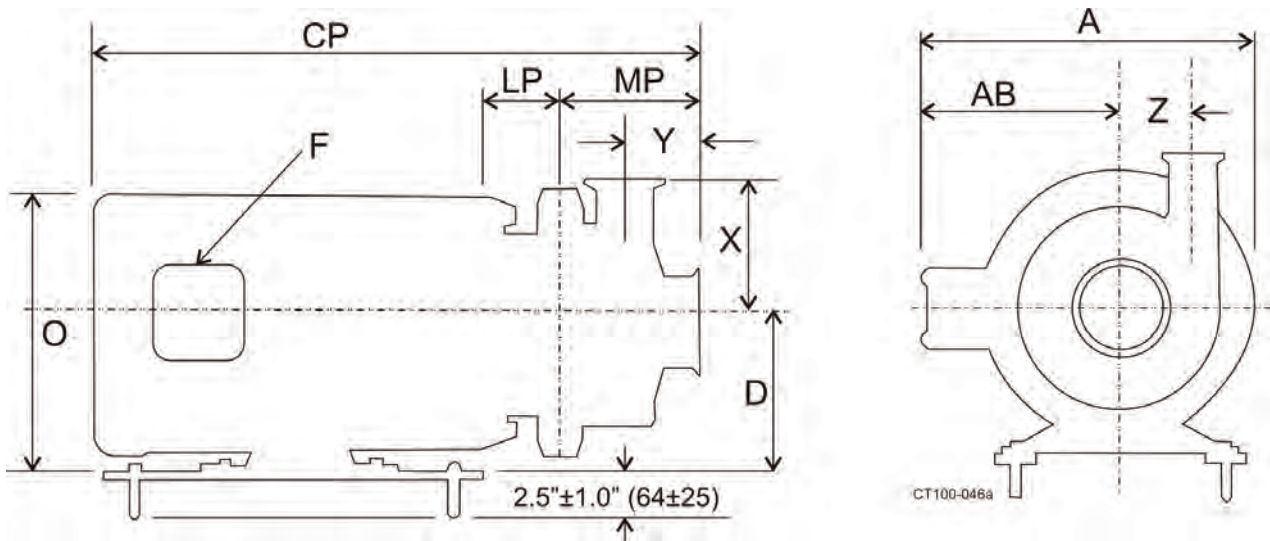

Figure 6 - Foot Print Dimensions

Table 4: Table of Dimensions for Figure 6, page 15

Frame	A inch (mm)	O inch (mm)	D inch (mm)	F inch (mm)	AB inch (mm)
145JM	9.32 (237)	7.1 (180)	3.5 (89)	0.88 (22)	5.73 (145)
182JM	9.32 (237)	8.1 (206)	4.5 (114)	0.88 (22)	5.73 (145)
184JM	11.11 (282)	8.49 (216)	4.5 (114)	1.09 (28)	6.87 (174)
213JM	13.18 (335)	10.39 (264)	5.25 (133)	1.38 (35)	8.04 (204)
215JM	13.18 (335)	10.39 (264)	5.25 (133)	1.38 (35)	8.04 (204)
254JM	15.34 (390)	11.39 (289)	6.25 (159)	1.38 (35)	9.40 (239)
256JM	15.34 (390)	11.39 (289)	6.25 (159)	1.38 (35)	9.40 (239)
284JM	20.78 (528)	14.44 (367)	7.0 (178)	2.0 (51)	13.12 (333)
286JM	20.49 (520)	14.44 (367)	7.0 (178)	2.0 (51)	13.12 (333)
324JM	23.05 (585)	16.25 (413)	8.0 (203)	2.5 (63)	14.61 (371)
326JM	23.05 (585)	16.25 (413)	8.0 (203)	2.5 (63)	14.61 (371)

NOTE: Figure 6 dimensions for the Inlet, Outlet, items X, Y, and Z are listed in Table 7 on page 17.

Table 5: Table of Dimensions for Figure 6, page 15

FRAME	PUMP SIZE							
	S2045		S2065		S2065LV		S2065HV	
	LP	CP	LP	CP	LP	CP	LP	CP
	Inches (mm)	Inches (mm)	Inches (mm)	Inches (mm)	Inches (mm)	Inches (mm)	Inches (mm)	Inches (mm)
145JM	2.92 (74)	18.18 (461)	2.71 (69)	18.43 (468)	2.71 (69)	17.93 (455)	2.71 (69)	18.85 (479)
182JM	2.92 (74)	19.56 (497)	2.71 (69)	19.81 (503)	2.71 (69)	19.31 (490)	2.71 (69)	20.23 (514)
184JM	2.92 (74)	20.81 (529)	2.71 (69)	21.01 (534)	2.71 (69)	20.56 (522)	2.71 (69)	21.43 (544)
213JM	--	--	2.97 (75)	22.81 (579)	2.97 (75)	22.31 (567)	2.97 (75)	23.23 (590)
215JM	--	--	2.97 (75)	23.94 (608)	2.97 (75)	23.44 (595)	2.97 (75)	24.36 (618)
254JM	--	--	3.97 (101)	26.07 (662)	3.97 (101)	25.57 (649)	3.97 (101)	26.49 (673)
256JM	--	--	3.97 (101)	27.83 (707)	3.97 (101)	27.33 (694)	3.97 (101)	28.25 (718)
284JM	--	--	3.97 (101)	31.43 (798)	3.97 (101)	30.93 (786)	3.97 (101)	31.85 (809)
286JM	--	--	3.97 (101)	31.64 (804)	3.97 (101)	31.14 (791)	3.97 (101)	32.06 (814)
324JM	--	--	--	--	--	--	--	--
326JM	--	--	--	--	--	--	--	--

Table 6: Table of Dimensions for Figure 6, page 15

Frame	Pump Size							
	S2075		S2085		S2085LV		S2092	
	LP	CP	LP	CP	LP	CP	LP	CP
	Inches (mm)	Inches (mm)	Inches (mm)	Inches (mm)	Inches (mm)	Inches (mm)	Inches (mm)	Inches (mm)
145JM	2.75 (70)	18.17 (461)	2.75 (70)	18.84 (478)	2.75 (70)	18.17 (461)	2.75 (70)	18.78 (477)
182JM	2.75 (70)	19.55 (497)	2.75 (70)	21.21 (513)	2.75 (70)	19.55 (497)	2.75 (70)	20.16 (512)
184JM	2.75 (70)	20.80 (528)	2.75 (70)	21.46 (545)	2.75 (70)	20.80 (528)	2.75 (70)	21.41 (544)
213JM	2.84 (72)	22.39 (569)	2.84 (72)	23.06 (586)	2.84 (72)	22.39 (569)	2.84 (72)	23.00 (584)
215JM	2.84 (72)	23.52 (597)	2.84 (72)	24.19 (614)	2.84 (72)	23.52 (597)	2.84 (72)	24.13 (613)
254JM	3.84 (98)	25.65 (651)	3.84 (98)	26.32 (668)	3.84 (98)	25.65 (651)	3.84 (98)	26.26 (667)
256JM	3.84 (98)	27.41 (696)	3.84 (98)	28.08 (713)	3.84 (98)	27.41 (696)	3.84 (98)	28.02 (712)
284JM	3.84 (98)	31.01 (788)	3.84 (98)	31.68 (805)	3.84 (98)	31.01 (788)	3.84 (98)	31.62 (803)
286JM	3.84 (98)	31.22 (793)	3.84 (98)	31.89 (810)	3.84 (98)	31.22 (793)	3.84 (98)	31.83 (808)
324JM	3.84 (98)	33.11 (841)	3.84 (98)	33.78 (858)	3.84 (98)	33.11 (841)	--	--
326JM	3.84 (98)	33.11 (841)	3.84 (98)	33.78 (858)	3.84 (98)	33.11 (841)	--	--

Table 7: Table of Dimensions for Figure 6, page 15

Model	Inlet inch (mm)	Outlet inch (mm)	X inch (mm)	Y inch (mm)	Z inch (mm)	MP inch (mm)
S2045	1.5 (38)	1.5 (38)	3.88 (99)	2.56 (65)	1.99 (51)	4.08 (104)
	2.0 (51)	1.5 (40)	3.88 (99)	2.56 (65)	1.99 (51)	4.08 (104)
S2065	2.5 (64)	2.0 (51)	4.94 (125)	2.68 (68)	2.88 (73)	4.53 (115)
S2065LV	1.5 (38)	1.5 (38)	4.94 (125)	2.43 (62)	3.13 (79)	4.03 (102)
	2.0 (51)	1.5 (38)	4.94 (125)	2.43 (62)	3.13 (79)	4.03 (102)
	2.5 (64)	1.5 (38)	4.94 (125)	2.43 (62)	3.13 (79)	4.03 (102)
S2065HV	3.0 (76)	2.0 (51)	4.94 (125)	3.04 (77)	2.88 (73)	4.96 (126)
S2075	3.0 (76)	1.5 (40)	6.69 (170)	2.70 (69)	4.32 (110)	4.24 (108)
S2085	3.0 (76)	2.5 (64)	5.75 (146)	2.93 (74)	3.82 (97)	4.91 (125)
	4.0 (102)	2.5 (64)	5.75 (146)	2.93 (74)	3.82 (97)	4.91 (125)
S2085LV	2.0 (51)	1.5 (40)	6.69 (170)	2.70 (69)	4.32 (110)	4.24 (108)
S2092	3.0 (76)	2.0 (51)	6.64 (169)	3.09 (78)	4.62 (117)	4.85 (123)

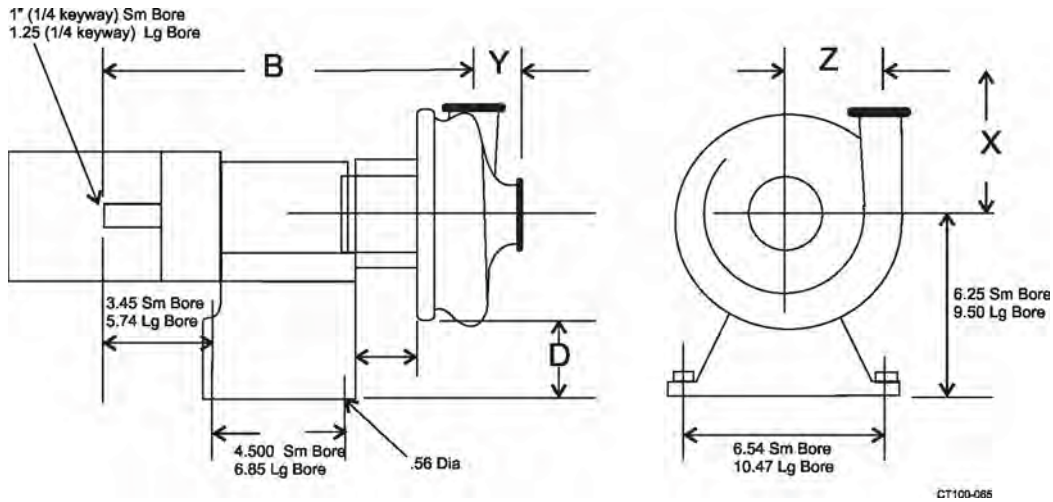

Figure 7 - Style "B" and "C" Less Base Plate

Table 8: Table of Dimensions for Figure 7

Model	Inlet inch (mm)	Outlet inch (mm)	B		D	
			Sm Bore inch (mm)	Lg Bore inch (mm)	Sm Bore inch (mm)	Lg Bore inch (mm)
PS2045	1.5 (40)	1.5 (40)	15.0 (381)	--	2.7 (69)	--
	2.0 (50)	1.5 (40)	15.0 (381)	--	2.7 (69)	--
PS2065LV	1.5 (40)	1.5 (40)	14.9 (378)	18.6 (472)	1.7 (43)	4.9 (124)
	2.0 (50)	1.5 (40)	14.9 (378)	18.6 (472)	1.7 (43)	4.9 (124)
	2.5 (65)	1.5 (40)	14.9 (378)	18.6 (472)	1.7 (43)	4.9 (124)
PS2065	2.5 (65)	2.0 (50)	15.1 (384)	18.9 (480)	1.7 (43)	4.9 (124)
PS2065HV	3.0 (75)	2.0 (50)	15.2 (386)	18.9 (480)	1.7 (43)	4.9 (124)
PS2075	3.0 (75)	1.5 (40)	14.7 (373)	18.4 (472)	.6 (15)	3.9 (99)
PS2085LV	2.0 (50)	1.5 (40)	14.7 (373)	18.4 (472)	.6 (15)	3.9 (99)
PS2085	3.0 (75)	2.5 (65)	15.1 (384)	18.9 (480)	.6 (15)	3.9 (99)
	4.0 (100)	2.5 (65)	15.1 (384)	18.9 (480)	.6 (15)	3.9 (99)
PS2092	3.0 (75)	2.0 (50)	14.9 (378)	18.6 (472)	.6 (15)	3.9 (99)

NOTE: Dimensions X, Y, and B apply to pumps with clamp connections.

Table 9: Table of Base Size Used on Pedestal-Mounted Centrifugal Pumps

Motor HP & RPM	Sanitary and Industrial Models						
	PS2045	PS2065LV	PS2065/ PS2065HV	PS2075	PS2085LV	PS2085	PS2092
Up to 5 HP 1750 RPM	SM.B.	SM.B.	SM.B.	SM.B.	SM.B.	SM.B.	SM.B.
Up to 5 HP 3500 RPM	SM.B.	SM.B.	SM.B.				
7.5 HP 1750 RPM						SM.B.	SM.B.
7.5 HP 3500 RPM		SM.B.	SM.B.	SM.B.	SM.B.	SM.B.	SM.B.
10 HP 1750 RPM						SM.B.	SM.B.
10 HP 3500 RPM		SM.B.	SM.B.	SM.B.	SM.B.	SM.B.	SM.B.
15 HP 1750 RPM							
15 HP 3500 RPM			SM.B.	SM.B.	SM.B.	SM.B.	SM.B.
20 HP 1750 RPM							
20 HP 3500 RPM			SM.B.	SM.B.	SM.B.	SM.B.	SM.B.
25 HP 1750 RPM							
25 HP 3500 RPM							
30 HP 1750 RPM							
30 HP 3500 RPM						LG.B.	LG.B.
40 HP 1750 RPM							
40 HP 3500 RPM						LG.B.	LG.B.
50 HP 1750 RPM							
50 HP 3500 RPM						LG.B.	LG.B.
60 HP 3500 RPM						LG.B.	LG.B.
75 HP 3500 RPM						LG.B.	LG.B.

SM.B. = Small Base

LG.B. = Large Base

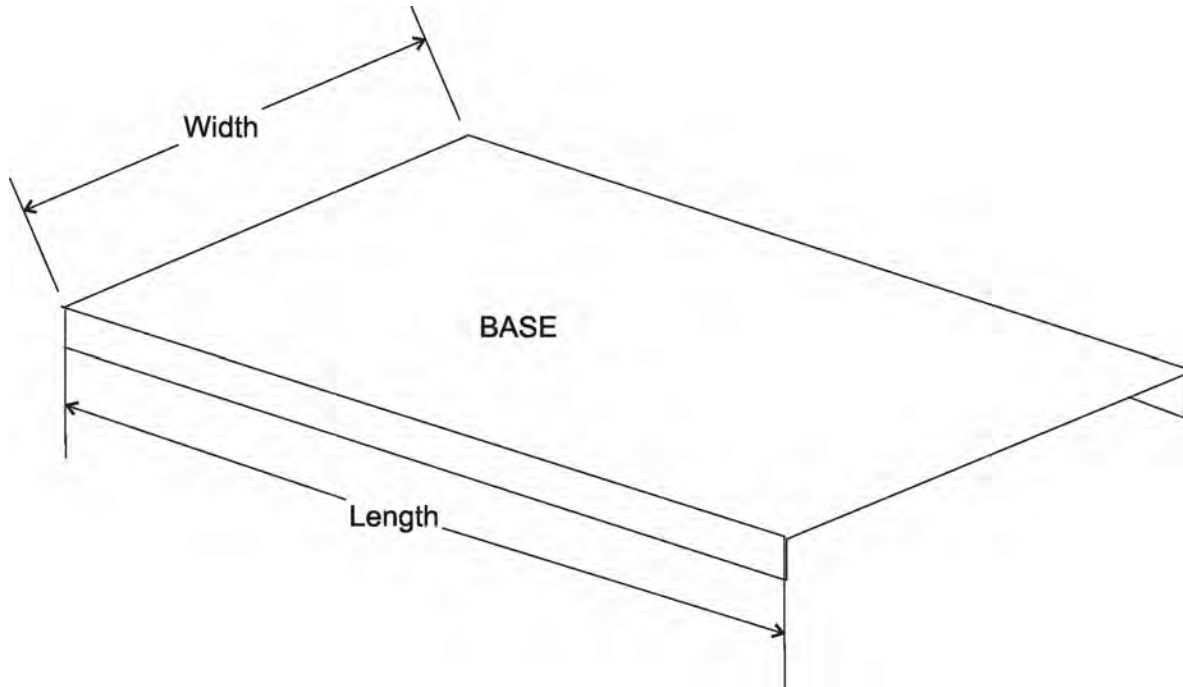

Figure 8 - Base Channel Dimensions for Pedestal Mounted Centrifugal Pumps

Baseplates are available in carbon steel channel base, carbon steel baseplate with feet or stainless steel baseplate with feet. Centrifugal S200 Series Pump and Pedestal Weights

Table 10: Base Channel Dimensions for Figure 8

Carbon Steel Channel Base	Carbon Steel Baseplate	Stainless Steel Baseplate
10 x 26		
12 x 32	12 x 26	12 x 32
15 x 32	14.6 x 32	17 x 41
15 x 40	17 x 41	17 x 50
16 x 41	17 x 50	
18 x 40		
18 x 50		

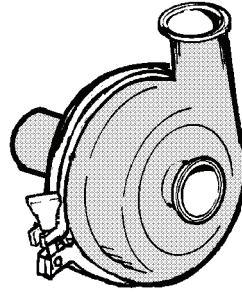

Figure 9 - Close Coupled Pump

Table 11: Close Coupled Pump (Less Motor and Legs)

Motor Frame	Pump Model							
	S2045 lbs (kg)	S2065LV lbs (kg)	S2065 lbs (kg)	S2065HV lbs (kg)	S2075 lbs (kg)	S2085LV lbs (kg)	S2085 lbs (kg)	S2092 lbs (kg)
143-184JM	21 (9.5)	31 (14)	33 (14.9)	39 (17.7)	57 (25.8)	57 (25.8)	51 (23.1)	51 (23.1)
213-215JM	35 (15.8)	37 (16.7)	39 (17.6)	64 (29)	54 (24.4)	54 (24.4)	78 (35.3)	78 (35.3)
254-256JM	37 (16.7)	39 (17.6)	41 (18.5)	67 (30.4)	57 (25.8)	57 (25.8)	79 (35.8)	79 (35.8)
284-326JM	51 (23.1)	53 (24)	71 (32.2)	68 (30.8)	82 (37.1)	82 (37.1)	--	--

Add 5LB. For Pumps With Double Seals

Table 12: Add Listed Weight for Legs

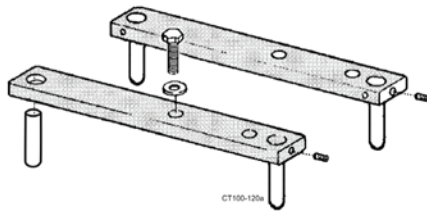

Figure 10 - Legs

Motor Frame	Weight lbs (kg)
143-213JM	10.5 (4.7)
215-254JM	12.5 (5.6)
254-326JM	42.5 (19.2)

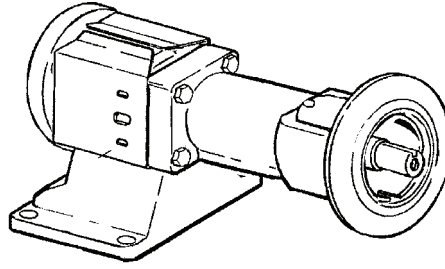

Figure 11 - Pedestal Pump (Less Base and Motor)

Table 13: Pedestal Pump (Less Base and Motor)

Pump Model								
PEDESTAL	S2045 lbs (kg)	S2065LV lbs (kg)	S2065 lbs (kg)	S2065HV lbs (kg)	S2075 lbs (kg)	S2085LV lbs (kg)	S2085 lbs (kg)	S2092 lbs (kg)
SMALL BORE	92 (41)	106 (48)	108 (48.9)	114 (51.7)	131 (59.4)	131 (59.4)	125 (56.6)	125 (56.6)
LARGE BORE	--	--	--	--	--	--	235 (106.5)	235 (106.5)

Table 14: Channel Base Weight
(Add to Pedestal Weight)

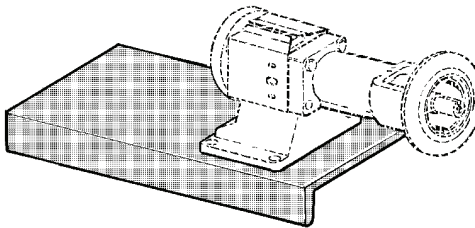

Figure 12 - Base Weight

Motor	Small Bore lbs (kg)	Large Bore lbs (kg)
56	30 (13.6)	--
143/145T	31 (14.6)	--
182/184T	32 (14.5)	50 (22.6)
213/215T	33 (14.9)	50 (22.6)
254/256T	40 (18.1)	52 (23.5)
284/286T	35 (15.8)	62 (28.1)
284/286TS	--	64 (29.0)
324/326T	--	65 (29.4)
324/326TS	--	65 (29.4)
364TS	--	65 (29.4)

Installation

Unpack all parts of your equipment and inspect for damages that may have occurred during shipping. Report any damage to the carrier.

All ports are covered at the factory to keep out foreign objects during transit. If the covers are missing or damaged, remove the pump cover and thoroughly inspect the fluid head. Be sure the pump head is clean and free of foreign material before rotating shaft.

Pump Location

Address the following considerations when determining a location for the installation of your pump:

- Locate the pump as near as is practical to the liquid supply.
- Keep the supply piping short and straight to keep the pump supplied with liquid and prevent damaging cavitation.
- The pump should be accessible for service and inspection during operation.
- The motor must be protected from flooding.

Pump Leveling

Level the pump by loosening the set screws (Figure 13, item A) to adjust the length of the legs.

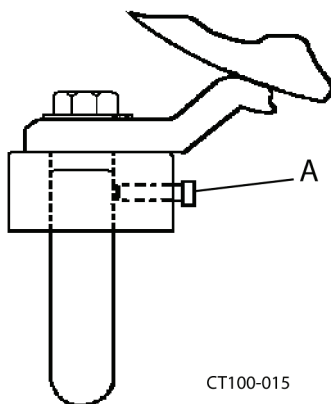

Figure 13 - Leveling Leg Set Screw Location

Supply and Discharge Piping/Valves

Address the following considerations when determining supply/discharge piping and valve installation of your pump.

1. Use a line size equal to or larger than the connection size on the pump, especially the inlet supply line.
2. Keep the supply line as short and straight as possible and use as few elbows, valves or other types of restrictions as possible. Avoid up and down rises which will trap air.
3. Be certain that all joints in the suction line are well-sealed to prevent air leaks.
4. Maintain a straight length of pipe (Figure 14, item A) at least 8 diameters long at the pump inlet.

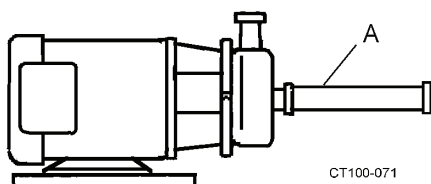

Figure 14 - Straight Pipe Length

Installation

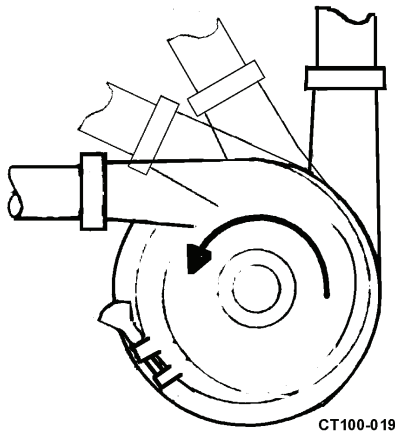

Figure 15 - Recommended Discharge Positions

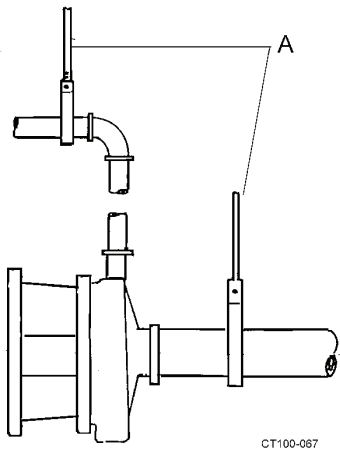

Figure 16 - Pipe Supports

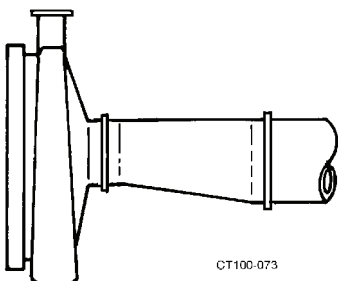

Figure 17 - Correct Eccentric Installation

5. The pump casing may be rotated with the discharge connection pointing in any direction. The best pump performance will be with the outlet up, to the left, or positions in between; these positions ensure a flooded casing and prevent problems due to air in the system. See Figure 15.
6. All joints in the suction line must be well-sealed to prevent air from being sucked into the system.

7. Support the supply and discharge piping near the pump so that no strain is put on the pump casing.
8. If an expansion joint is used, install a pipe anchor between the joint and the pump.

9. If a reducer is connected to the inlet, use an eccentric-type reducer to prevent problems due to trapped air. See Figure 17.



DANGER: The pump and piping may contain sharp edges. Wear gloves while installing and servicing the pump to help avoid injuries from these hazards.

10. The line slope will depend on application requirements; the best pump operation is with supply line sloped slightly upward toward the pump to prevent trapping air. If the system must drain into the pump casing, keep the downward slope to a minimum or priming problems may occur.
11. Install shutoff valves to isolate the pump from the supply and discharge lines. This will allow the pump to be serviced without draining the system.

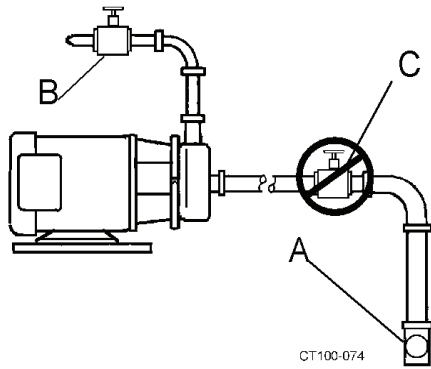

Figure 18 - Valve Piping Installation

12. This pump is not self priming. If the pump is installed above the supply liquid level, install a foot valve or other system check valve to keep the system flooded for priming. (Figure 18, item A).
13. A throttling valve may be required to control the pump flow rate to prevent motor overload. Always install a throttling valve (Figure 18, item B) in the discharge piping, at least 10 pipe diameters from the pump outlet.



CAUTION: Never install throttling valve in the supply piping. (Figure 18, item C).

Installations That May Cause Operation Problems

1. Any system throttling valves or similar devices to control flow rate must be installed in the discharge line.



CAUTION: Do not install any system throttling valves or similar devices to control flow rate in the supply line. Restriction in the supply line may cause cavitation and pump damage.

2. "Water hammer" in the system can damage the pump and other system components. Water hammer often occurs when valves in the system are suddenly closed, causing lines to move violently with a loud noise. When this condition is present, find and eliminate the source of the water hammer. One way to eliminate water hammer is to slow down the actuation speed of the valve.
3. Do not expose the pump to freezing temperatures with liquid in the casing. Frozen liquid in the casing will damage the pump. Drain the casing before exposing the pump to freezing temperatures.

Electrical Connections



DANGER: To avoid electrocution, ALL electrical installation should be done by a registered Electrician, following Industry Safety Standards. All power must be OFF and LOCKED OUT during installation.



Figure 19 - Replaceable Label Location

1. Read the motor manufacturer's instructions before installing. Follow manufacturer's lubrication schedules.
2. Check the motor nameplate to be sure that the motor is compatible with the electrical supply and all wiring, switches, and starters. Make sure all overload protections are correctly sized. See Figure 19.
3. Check the pump rotation following the electrical installation. Correct rotation is counter-clockwise when facing the pump inlet connection. See Figure 15 and Figure 19.

Installation

Flush Seal Option

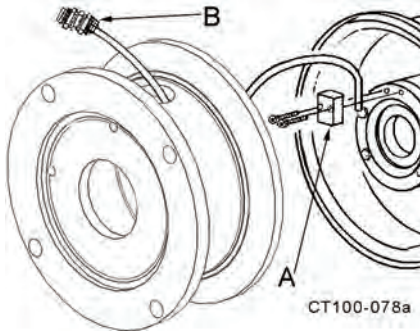

Figure 20 - Cascade System Installation

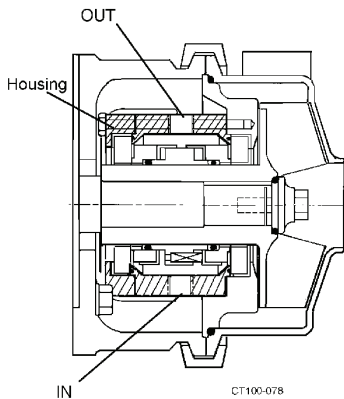

Figure 21 - Type 4 Flush Housing

Before First Startup

When this option is ordered, a fitting assembly (Figure 20, item A) is supplied for directing a flow of water onto the backplate/seal area.

- The water cascade block must be above the seal on the assembled backplate to flow water onto the seal face.
- The connection (Figure 20, item B) is 1/4 inch O.D. tubing.
- The required flow is approximately 5 U.S. gallons per hour.
- The recommended water supply is cool and filtered. If the product solidifies at cool temperature, warm or hot water can be used.

NOTE: To prevent hose contact with the rotating shaft and seal parts during operation, pull any excess hose to the outside of the seal guard.

Type 4 Seal (Double mechanical with flush)

Attach the seal flush supply to the bottom 1/4-inch pipe threaded hole in the flush housing. The drain tubing attached to the top hole allows moderate pressure to be supplied to the seals and allows continuous flooding. See Figure 21.

Clean Pump and Piping

Disassemble pump and clean all product contact parts and seal parts prior to first operation. Follow instructions in the "Cleaning Safety Procedures" on page 27 and "Routine Maintenance" on page 28. The pump should be thoroughly cleaned of any materials which could have accumulated during installation.

Cleaning Safety Procedures



WARNING: To prevent an accidental start-up, lock out the power source with lock and key.

Manual Cleaning

Address the following considerations when manually cleaning your pump:

1. Do not use toxic and/or flammable solvents.
2. Lock out electrical power and shut off all air prior to cleaning the equipment.
3. Keep electrical panel covers closed and power off when washing the equipment.
4. Clean up spills as soon as possible.
5. Never attempt to clean the equipment while it is operating.
6. Wear proper protective clothing.

Cleaning-In-Place (CIP)

When performing CIP do the following:

1. Make certain that all connections in the cleaning circuit are properly applied and tight to avoid contact with hot water or cleaning solutions.
2. When cleaning cycle is controlled from a remote or automated cleaning center, establish safe procedures to avoid automatic start-up while servicing equipment in the circuit.

Preliminary Test Run

Test the system using a preliminary run with the materials that will be pumped. **DO NOT** run the pump at this time to produce final product.

See “Starting the Pump” on page 27.

Check For Possible Motor Overload Conditions

Certain combinations will overload the motor when operated with open unrestricted discharge, resulting in an unacceptably high flow rate. Additional discharge restriction may be required to lower the flow rate and lower the horsepower requirement. **DO NOT** add a restriction to the supply line. If the pump was incorrectly selected, a smaller impeller or a higher motor horsepower may be required.

If you are uncertain about pump selection and application, temporarily install an ammeter in the electrical service.

Ammeter Test



DANGER: To avoid electrocution and equipment damage, only a qualified electrician should install the ammeter.

Operate the pump under process conditions and check the motor amp draw versus the nameplate full load rating. If the amp draw exceeds the motor rating, a system change or pump change is required.

If the process conditions and/or the liquid changes (higher viscosity, higher specific gravity) recheck the motor amp draw.

Operation

Operation

Before proceeding, make sure your pump has been correctly installed as described in "Installation" on page 23.

Starting the Pump

1. If pump has a flush seal option, start the flow of flush water (approximately 5 US gallons per hour recommended rate) before operating the pump.
2. Prime the pump by flooding the pump casing with liquid **BEFORE** starting the pump to avoid damage to pump parts. See "Priming the Pump With the Feed Source Above Pump Level" on page 28 or "Priming the Pump With the Feed Source Below Pump Level" on page 29.
3. Start the pump motor and check the motor rotation to make sure it is in the same direction as the arrow on the pump.
4. Check the pump to see that liquid is flowing and that all piping connections and seals are leak-free.
5. Make sure that the pump is not operating against a closed discharge. Continued operation against a closed discharge will heat the liquid in the casing to boiling and lead to pump damage.
6. Slowly open the discharge valve until the desired flow is obtained. Observe pressure gauges and if pressure is not attained quickly, stop the pump and prime it again.

Priming the Pump

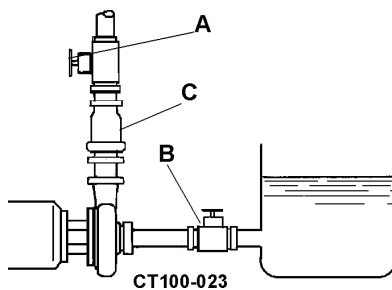

**Figure 22 - Pump Below Supply
(Feed Source Above Pump Level)**

Priming the Pump With the Feed Source Above Pump Level

1. Fill the supply tank with liquid; open the supply line valve (suction) (item B).
2. Vent any air trapped in the supply line or casing by opening the discharge valve. (item A).
3. Start the pump.

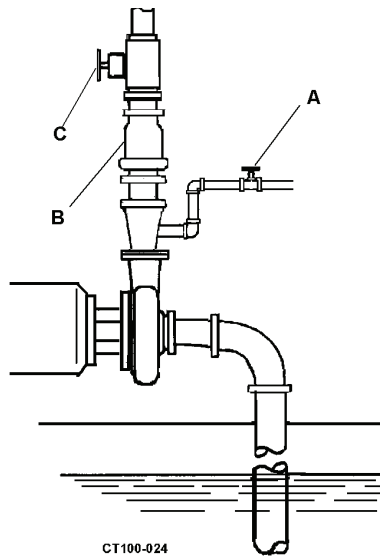

**Figure 23 - Pump Above Supply
(Feed Source Below Pump Level)**

Priming the Pump With the Feed Source Below Pump Level

The pump will not self-prime if the liquid supply is below the pump level. When the liquid supply is below the pump level, an outside source must be provided for priming.

1. Close the discharge valve (item C) and open the air vents.
2. Open the valve installed in the outside supply line (item A) until liquid flows from the vent valves.
3. Close the vent valves.
4. Close the outside supply line.

NOTE: Use a check valve system (item B) to keep the supply line and pump casing flooded with liquid; otherwise the pump must be primed before each operation.

Stopping the Pump

1. To stop the pump, shut off the power to the pump motor.

NOTE: Liquid in system can flow freely through the pump; the pump does not act as a shutoff valve.

2. Shut off supply and discharge lines.

Maintenance

Maintenance

Scheduled Maintenance

A routine maintenance program can extend the life of your pump. Make sure to keep maintenance records. These records will help pinpoint potential problems and causes.

Routine Maintenance

Your scheduled routine maintenance should include the following items:

- Check for unusual noise, vibration and bearing temperatures
- Inspect pump and piping for leaks
- Check Mechanical Seal area for leakage. No leakage is desired.
- Check backplate gasket for wear/damage.
- Bearing lubrication (See motor manufacturer for correct specifications)
- Seal Monitoring
- Vibration analysis
- Check discharge pressure
- Temperature monitoring

Pump Disassembly with Type 1 Seal

1. Shut off product flow to the pump and relieve any product pressure.
2. Shut off and lock out power to the pump.
3. Disconnect the suction and discharge pipe fittings.
4. Remove the casing clamp and casing.
5. Slide the o-ring off the backplate.
6. Remove the impeller retainer bolt and shaft o-ring.

NOTE: The retainer bolt has standard right hand threads.

Removal of the Water Cascade

1. Loosen the socket head screws holding the water cascade block on the stationary seat retainer and remove the plastic hose.
2. Pull off the impeller/backplate assembly and place it on a clean flat surface with impeller shaft up.

NOTE: If the assembly cannot be removed from the motor shaft by hand, contact Waukesha Cherry-Burrell Customer Service.

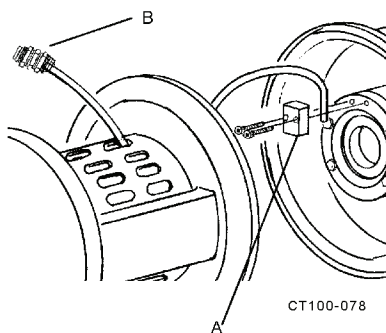

Figure 24 - Removal of the Water Cascade System

3. Locate shims on the motor shaft and remove them.

NOTE: Motor shaft shims may fall off the motor shaft or hang up inside the deflector. **Be sure to place all shims back on the motor shaft.**



CAUTION: Handle the impeller/backplate assembly with care to prevent damage to seal components.

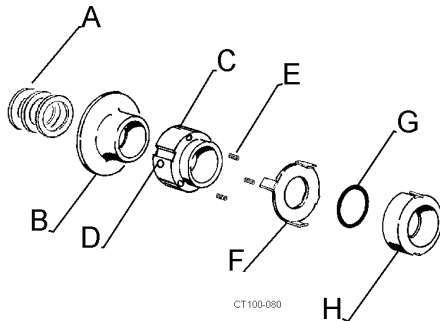

Figure 25 - Type 1 Seal Items



Figure 26 - Moving the Rotary Seal up the Shaft



Figure 27 - Push Rotary Seal Down Until the o-ring is Released.

4. Remove the deflector (Figure 25, item B).
5. Loosen (2) set screws (Figure 25, item D) in the spring retainer (item C) and slide the retainer and washer (item F) off the shaft. Save (3) springs (item E).
6. Use the backplate to slide the rotary seal up the impeller shaft approximately 1-1/2 inches. See Figure 26.

7. With the backplate resting on the impeller, push the rotary seal toward the backplate until the o-ring is free. See Figure 27.
8. Remove the o-ring, then lift the rotary seal off the shaft. (See Figure 25, items G and H)



CAUTION: To avoid seal failure, DO NOT place fingers on the carbon seal face.

9. Lift the backplate off the impeller.

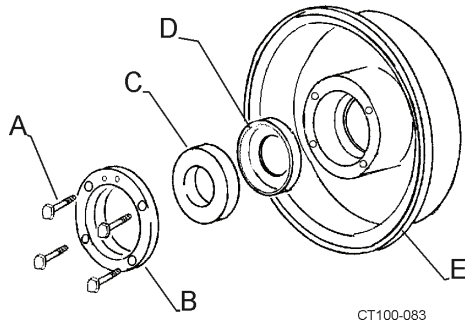

Figure 28 - Removing Stationary Seal

10. Remove four 1/4" hex bolts and stationary seat retainer ring. (See Figure 28, items A and B).
11. Pull the stationary seal and L-gasket out of the backplate. (See Figure 28, items C and D).

NOTE: The stationary seal is brittle. Prying or hammering on the seal plate can shatter the seal. If the stationary seal cannot be removed by hand, place a 2-1/4 inch diameter plastic or wood rod on the impeller side of the seal and apply even pressure to dislodge the seal.

Inspect Parts

Once disassembly is complete, perform the following inspections.

1. Examine all seal surfaces and replace seals that have become scratched, cracked and/or braised.
2. Inspect all o-rings and o-ring seats for abrasions, cuts or other wear that could cause leakage.
3. Clean all seat areas and alignment surfaces.

NOTE: Stationary seals are **reversible**. Use **both sides** before replacing.

NOTE: Replace the rotary seal when the seal face extends less than 1/32 inch (1mm) from the body See Figure 29.

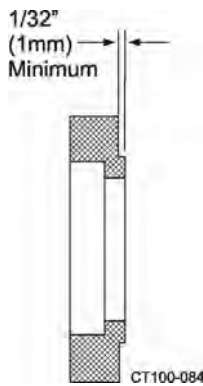

Figure 29 - Replace Rotary Seal if Less Than Minimum

Pump Assembly with Type 1 Seal

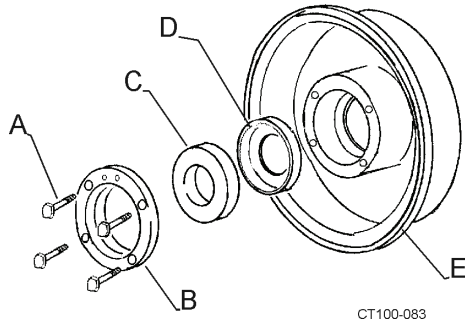

Figure 30 - Stationary Seal Assembly

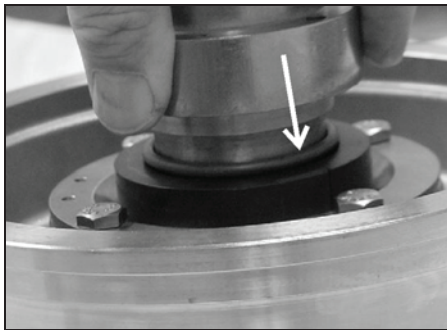

Figure 31 - Installing o-ring Using the Spring Retainer.

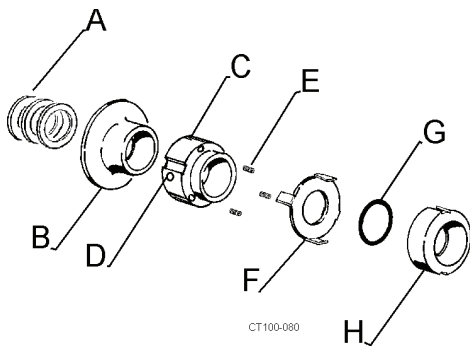

Figure 32 - Type 1 Seal Assembly

Backplate Assembly

1. Lightly lubricate both sides of the L-gasket (Figure 30, item D) with a sanitary lubricant and insert into the backplate seal cavity.
2. Place the stationary seal into the L-gasket. (See Figure 30, items C and D).
3. Place the seat retainer over the stationary seal and secure the retainer with four 1/4-20 x 1/2 inch hex head cap screws. (See Figure 30, items B and A).
4. Tighten the cap screws evenly.

Backplate/Impeller Assembly

1. Place the impeller on a clean flat surface, shaft end up, and slide the assembled backplate onto the impeller shaft.

NOTE: Avoid hitting the stationary seal against the impeller shaft, as this could break the seal.

2. Carefully place the rotary seal in position over the impeller shaft and down against the stationary seal.
3. Lubricate and slide the seal o-ring onto the impeller shaft. (Use the spring retainer as a tool to push the o-ring into the rotary seal). See Figure 31.
4. Slide the tabbed washer (Figure 30, item F) over the impeller shaft and engage the tabs of the washer into notches on the outside of rotary seal. (See Figure 32, items F and H).
5. Install the three seal springs into the holes in the spring retainer (See Figure 32, items C and E). Hold the springs in place with RTV silicone sealant.
6. Slide the spring retainer over the impeller shaft until the slots in the spring retainer engage the drive tabs on washer and the springs rest against the washer. See Figure 32.
7. With the backplate against the impeller, push the spring retainer down to compress the springs until the length of visible spring is approximately 1/8".
8. Lock the spring retainer in place by tightening the set screws. (Figure 32, item D).
9. Install the deflector onto the impeller shaft (Figure 32, item B).

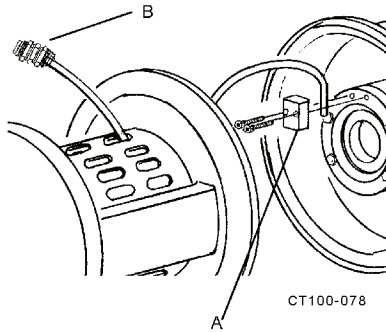

Figure 33 - Installing the Water Cascade System

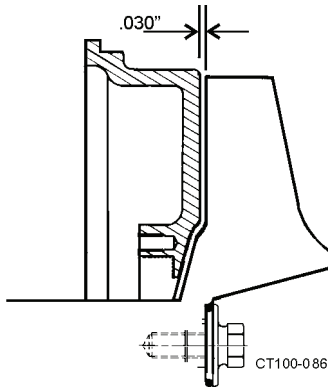

Figure 34 - Clearance Between Impeller and Backplate

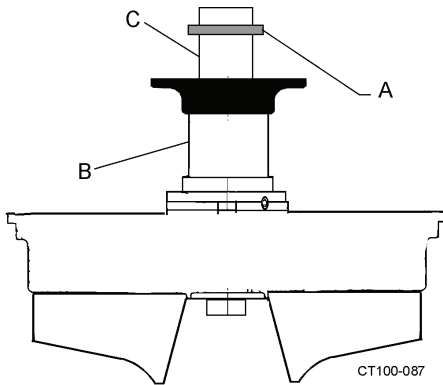

Figure 35 - Locations of Shims

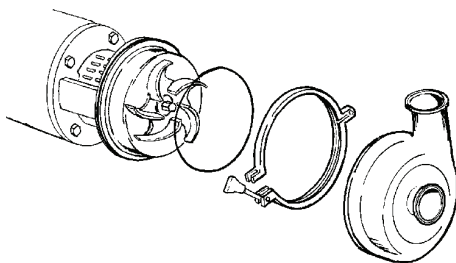

Figure 36 - Install Casing

10. If your system has a water cascade, thread the water cascade hose through the guard and install the cascade block on the backplate (See Figure 33, items A and B).
11. Slide the motor shims onto the shaft. Use the same number of shims that were removed when the pump was disassembled.
12. Install the impeller assembly on the stub shaft of the motor.
13. Hand-tighten the impeller retainer bolt on the shaft.
14. Check the space between the back of the impeller and the backplate with a feeler gauge (.030 nominal) while holding the backplate tight against the bearing housing flange. (Any axial movement of the shaft should not be added to the .030 nominal clearance). See Figure 34. If needed, change this clearance by adding or removing shims. Shims (Figure 35, item A) are added on the drive shaft (item C) behind the impeller shaft (item B).
15. Confirm operating clearances by clamping the casing to the bearing housing flange and rotating the shaft/impeller manually to be sure the impeller does not touch the casing or backplate.
16. When the proper shim pack is confirmed, remove the backplate/impeller assembly leaving the shim pack on the shaft.
17. Apply anti-sieze or equal compound to the motor shaft and install the key.
18. Install the backplate/impeller assembly and lock it in place using the o-ring and impeller retainer nut. Tighten with a wrench.
19. Install the casing o-ring on the backplate and clamp the casing in place. See Figure 36.

NOTE: Rotate the impeller manually to ensure that it does not rub on the backplate or casing.

Pump Disassembly with Type 4 Double Seal

The Type 4 Seal is essentially two Type 1 seals assembled back to back in a chamber which bolts to the backplate in place of the stationary seat retainer. Except for the additional components, (e.g. chamber, seals) Type 1 and Type 4 components are interchangeable. See Figure 37.

CAUTION: Handle the impeller/backplate assembly with care to prevent damage to seal components.

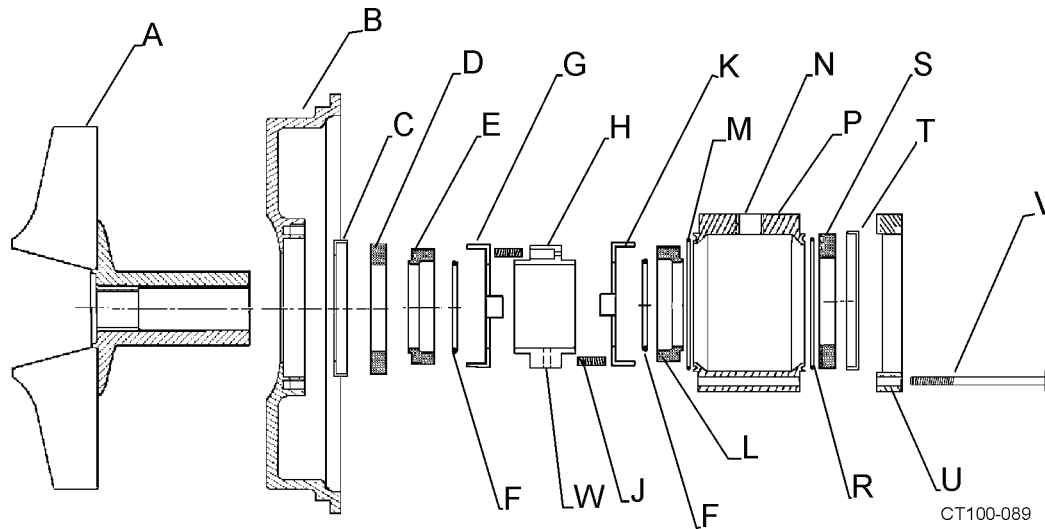

Figure 37 - Type 4 Seal Components

Table 15: Callouts for Figure 37

A. Impeller	F. O-ring	L. Rotary Seal	S. Stationary Seal
B. Backplate	G. Washer	M. O-ring	T. L-gasket
C. L-gasket	H. Spring Retainer	N. NPT Port	U. Seat Retainer
D. Stationary Seal	J. Spring	P. Flush Housing	V. Hex Head Screw (4)
E. Rotary Seal	K. Washer	R. O-ring	W. Set Screw

1. Shut off product flow to the pump and relieve any product pressure.
2. Shut off and lock out power to the pump.
3. Disconnect the suction and discharge pipe fittings.
4. Remove the casing clamp and casing. Slide the o-ring off the backplate.
5. Remove the impeller retainer bolt and shaft o-ring.

NOTE: The retainer bolt has standard right hand threads.

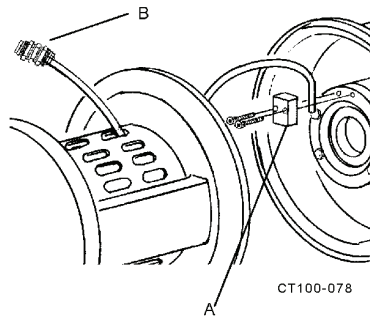

Figure 38 - Removal of the Water Cascade System

Removal of the Water Cascade

If your system is equipped with a water cascade system, remove it before proceeding:

1. Loosen the socket head screws holding the water cascade block on the stationary seat retainer and remove the plastic hose.
2. Pull off the impeller/backplate assembly and place it on a clean, flat surface with the impeller shaft facing up.

NOTE: If the assembly cannot be removed from the motor shaft by hand, contact Waukesha Cherry-Burrell Customer Service.

3. Locate the shims on the motor shaft and remove them.

NOTE: Motor shaft shims may fall off the motor shaft or hang up inside the deflector. **Be sure to place all shims back on the motor shaft.**



CAUTION: Handle the impeller/backplate assembly with care to prevent damage to the seal components.

4. Place the impeller assembly **face down** (on impeller vanes) and remove the hex head screws (Figure 37, item V) from the back of the seal assembly.
5. Carefully lift off the seat retainer, o-ring, L-gasket, stationary seal and flush housing (See Figure 37, items P, R, T, S and U).
6. Loosen (2) set screws in the spring retainer (See Figure 37, items W and H).
7. Lift off rotating seal components (See Figure 37 on page 35):
 - Rotary Seal (item L)
 - O-ring (item M)
 - Washer (item K)
 - Spring Retainer (item H)
 - Springs (six total, 3 up and 3 down) (item J)
 - Washer (item G)

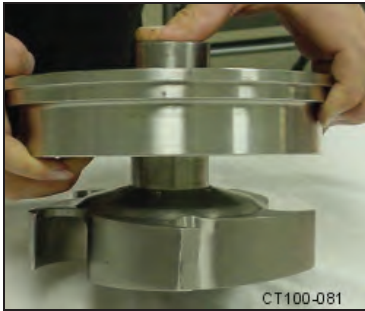

Figure 39 - Moving the Rotary Seal up the Shaft



Figure 40 - Push Rotary Seal Down Until o-ring is Released.

8. Use the backplate to slide the rotary seal up the impeller shaft approximately 1-1/2 inches. See Figure 39.

9. With the backplate resting on the impeller, push the rotary seal toward the backplate until the o-ring is free. See Figure 40.

10. Remove stationary seal and L-gasket from backplate. (See Figure 37, items D and C).

NOTE: The stationary seal is brittle. Prying or hammering on the seal plate can shatter the seal. If the stationary seal cannot be removed by hand, place a 2-1/4 inch diameter plastic or wood rod on the impeller side of the seal and apply even pressure to dislodge the seal.

11. Inspect and replace all damaged and worn parts.

Pump Assembly with Type 4 Double Seal

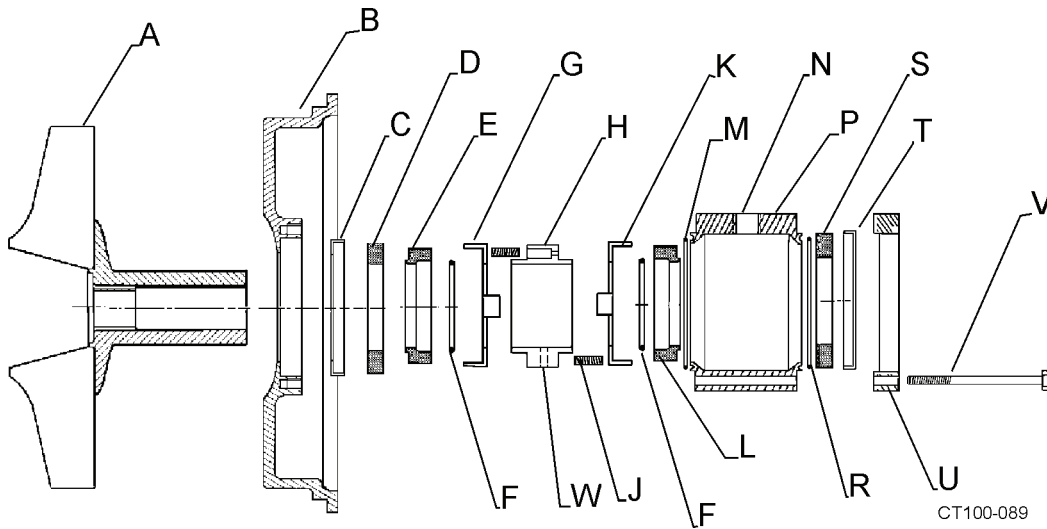

Figure 41 - Type 4 Seal Components

Table 16: Callouts for Figure 41

A. Impeller	F. O-ring	L. Rotary Seal	S. Stationary Seal
B. Backplate	G. Washer	M. O-ring	T. L-gasket
C. L-gasket	H. Spring Retainer	N. NPT Port	U. Seat Retainer
D. Stationary Seal	J. Spring	P. Flush Housing	V. Hex Head Screw (4)
E. Rotary Seal	K. Washer	R. O-ring	W. Set Screw

1. Clean all parts and lubricate all elastomer (Rubber-like) parts



CAUTION: Handle the impeller/backplate assembly with care to prevent damage to the seal components.

2. Install L-gasket in backplate. (See Figure 41, items B and C).
3. Install L-gasket in seat retainer. (Figure 41, item T).
4. Install stationary seals (Figure 41, item S) in L-gaskets.
5. Place backplate and rotary seal onto impeller shaft.

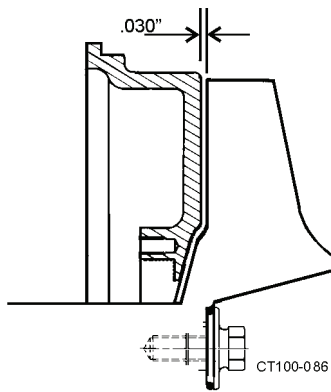

Figure 42 - Place Shims Between Impeller and Backplate

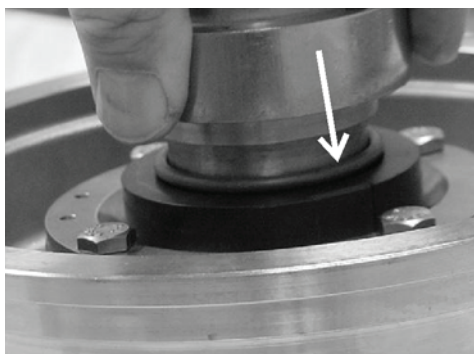

Figure 43 - Installing the o-ring using the Spring Retainer.

6. Temporarily put 0.03" shims between the impeller vane and back plate to preset clearance. **Be sure to remove shims before final assembly.** See Figure 42.
7. Place the o-ring (Figure 41, item F) on the shaft and use a spring retainer to push o-ring into the rotary seal. See Figure 43.
8. Place the washer (Figure 41, item G) over the rotary seal with tabs in the outside diameter notches.
9. Place the three springs (Figure 41, item J) in one side of the spring retainer (hold them in place with silicone sealer) and slide the spring retainer (with the springs down) onto the impeller shaft against washer.
10. Place the remaining three (3) springs in the spring retainer.
11. Slide the washer and o-ring (See Figure 41, items K and F) onto the shaft against the spring retainer.
12. Use the spring retainer to press the o-ring into the rotary seal.
13. Remove the 1/4 NPT plug from the center port on the flush housing. (See Figure 41, page 38, item N).
14. Install an o-ring (See Figure 41, items R and M) in both ends of the housing.
15. Install the L-gasket in the seat retainer. (See Figure 41, items T and U).
16. Install the stationary seal (Figure 41, item S) in the L-gasket.
17. Install the housing over the seal assembly.
18. With the flush ports facing away from the backplate, place the seat retainer (Figure 41, item U) on the housing.
19. Tighten the seat retainer in place with four (4) hex screws (Figure 41, item V).

NOTE: Be sure to tighten the screws evenly until full metal-to-metal contact is made on the backplate and seat retainer.

20. Install the original shims on the motor adapter shaft.
21. Install the backplate with the seal assembly and impeller on the motor shaft.
22. Check the impeller/backplate clearance with the backplate held firmly in position against motor adapter. Check the space between the back of the impeller and the backplate with a feeler gauge (.030 nominal) while holding the backplate tight against the bearing housing flange. (Any axial movement of the shaft should not be added to the .030 nominal clearance). See Figure 44.

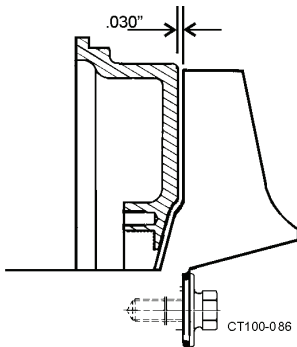

Figure 44 - Clearance Between Impeller and Backplate

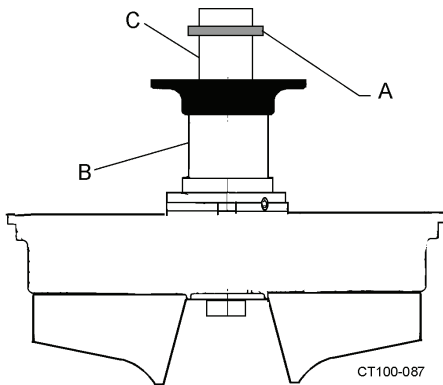

Figure 45 - Locations of Shims

23. If needed, change this clearance by adding or removing shims. Shims (Figure 45, item A) can be added on the drive shaft (Figure 45, item C) behind the impeller shaft (Figure 45, item B).
24. Confirm operating clearances by clamping the casing to the bearing housing flange and rotating the shaft/impeller manually to be sure the impeller does not touch the casing or backplate.
25. Tighten the set screws in the spring retainer through the 1/4 NPT center port in flush housing (Figure 41, item N).
26. Insert the plug in the port and tighten.
27. Remove the backplate/impeller assembly, apply anti-seize or equal compound to the motor shaft, and install the key.
28. Install the backplate/impeller assembly and lock it in place using the o-ring and impeller retainer bolt.
29. Install the casing o-ring on the backplate and clamp the casing in place. See Figure 46.

NOTE: Rotate the impeller manually to ensure that it does not rub on the backplate or casing.

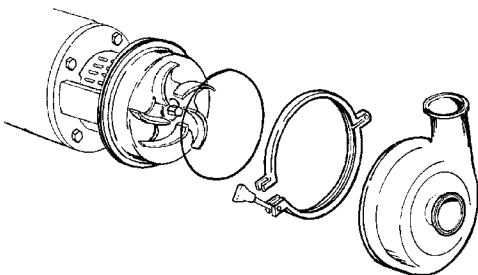

Figure 46 - Install Casing

Disassembly of Modular Base Mounted Pumps

Refer to see "Pump Disassembly with Type 1 Seal" on page 30 and "Pump Disassembly with Type 4 Double Seal" on page 35 for information on disassembling the pump seal items.

1. Shut off product flow to pump and relieve any product pressure.
2. Shut off and lock out power to the pump.
3. Disconnect the suction and discharge pipe fittings.
4. Remove the casing clamp and casing (Figure 47, item C). Slide the o-ring off the backplate.
5. Remove the impeller retainer nut and shaft o-ring (Figure 47, item B).
6. Pull the impeller/backplate assembly off the bearing housing shaft (See Figure 47, items D and A).

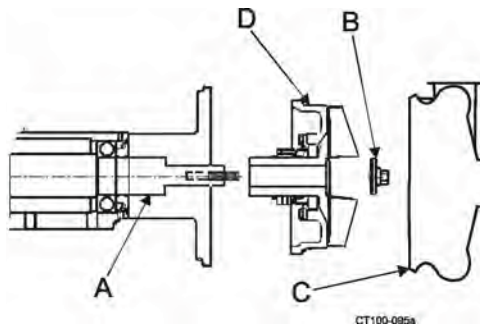

Figure 47 - Removing the Impeller Assembly

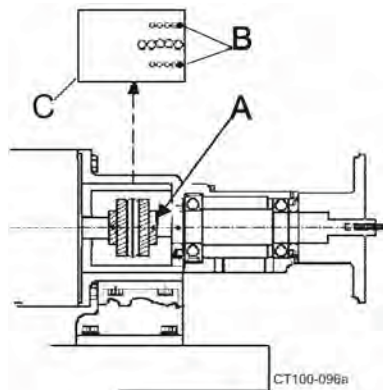

Figure 48 - Removing Coupling Covers

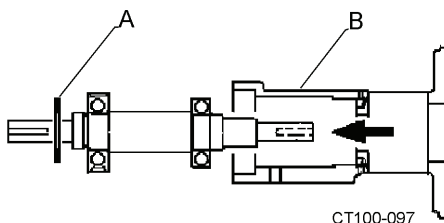

Figure 49 - Bearing Shaft Assembly Removal

7. Remove the coupling cover cap screws. (Figure 48, item B).
8. Loosen the set screws on the pump coupling. (Figure 48, item A).
9. **For Style B:** Remove the bolts from the adapter and stand. Remove the housing and stand as a unit.

For Style C: Remove the stand/housing assembly, then remove end cap. (Figure 52, item C on page 42).

10. Push the shaft and bearing assembly out of the housing from the impeller end. See Figure 49.
11. Remove the retaining ring and press the bearings off the shaft (See Figure 49, items A and B).

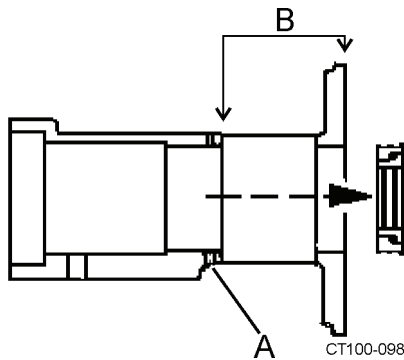

Figure 50 - Remove Set Screws

Disassembling The Outer Seal Assemblies

1. Using a 1/8" hex wrench, loosen the set screws (Figure 50, item A).
- NOTE:** The set screws are located opposite the grease fittings in the adapter or end cap.
2. Remove the impeller end of the bearing housing. (Figure 50, item B).
 3. Remove the outer seal ring assemblies (the inner seal ring and o-rings). See Figure 50 and Figure 51.

Assembling the Outer Seal Assemblies

Reverse the above disassembly procedure with the added step of installing new o-rings in the seal rings.

NOTE: Figure 51 shows the seal position at the motor end. Seals at the pump end face inward. Make sure to tighten the set screws when installing the outer seal assemblies. See Figure 52.

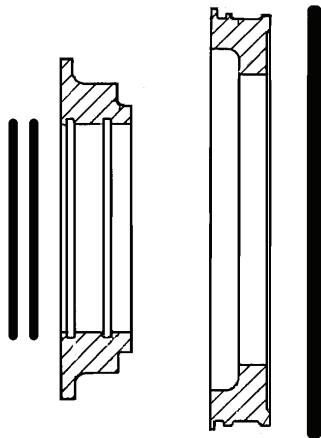

Inner Seal Outer Seal

Figure 51 - Seal Configuration

NOTE: Replace all rubber parts whenever a unit is dismantled for inspection or repair. Lubricate rubber parts with an approved/sanitary lubricant prior to assembly.

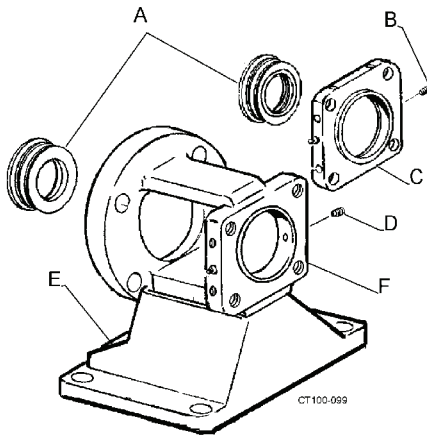

Figure 52 - Outer Seal Assemblies

A. Outer Seal Assembly	D. Set Screw
B. Set Screw	E. Adapter
C. End Cap	F. Stand

Pre-assembled (Cartridge) Seals

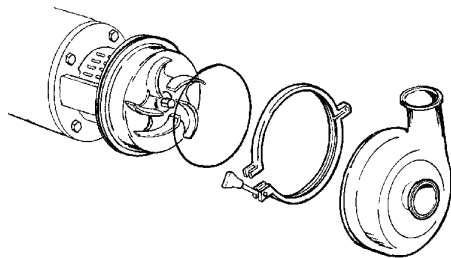

Figure 53 - Remove Casing Clamp, Casing and o-ring

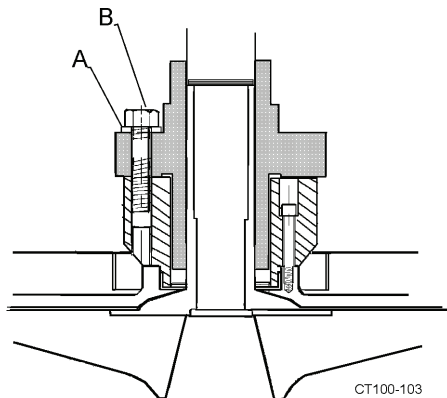

Figure 54 - Removal of Wet End

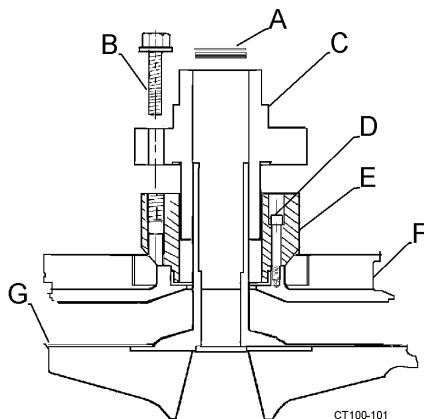

Figure 55 - Remove Seal Assembly.

Table 17: Callouts for Figure 55

A. Shims	E. Adapter
B. Cap Screw	F. Backplate
C. Cartridge Seal	G. Impeller
D. Socket Head Screw	

Pre-assembled (Cartridge) seals have all the seal components mounted to a flange, and are pre-adjusted at the factory. Follow the seal manufacturer's (John Crane, A. W. Chesterton, etc.) recommendations regarding application, operation, and maintenance.

NOTE: The cartridge seal comes with a set of removable lugs/spacers in place that are used to hold the assembly together until installation is final. Do not remove these lugs until installation is complete and you are instructed to do so on page 45 in step 17.

Disassembly of Pre-assembled (Cartridge) Seals

The following procedure covers the disassembly of pre-assembled (cartridge) seals.

1. Remove all flush connections and fittings.
2. Remove the casing clamp, casing and o-ring from the housing flange. See Figure 53.
3. Remove the impeller retainer nut and o-ring; then loosen the seal set screws. (Figure 54, item A).
4. Pull the impeller, backplate and seal off the bearing shaft as a unit. Set the assembly face down (on the impeller).

NOTE: The clearance shims that position the impeller within the casing are at the end of the impeller hub (inside the seal.) Keep shims together as a set for reassembly. See Figure 55.

5. Remove cap screws (Figure 55, item B) holding the cartridge seal to the seal adapter. (See Figure 55, items C and E).
6. Remove seal unit from the backplate assembly.
7. Pull seal from seal adapter. (See Figure 55, items C and E).
8. Remove seal adapter by removing socket head cap screws (Figure 55, item D) holding adapter to the back plate.

Assembly of a Pump With Pre-assembled (Cartridge) Seals

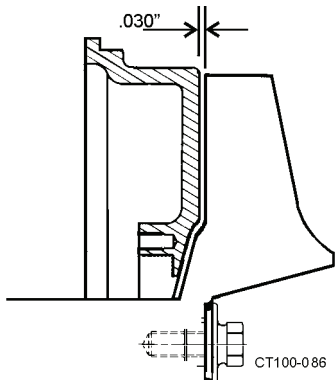

Figure 56 - Clearance Between Impeller and Backplate

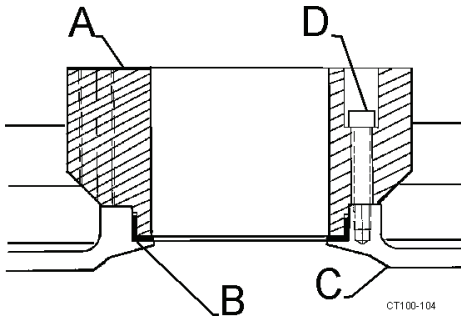

Figure 57 - Insert L-gasket and Fasten Adapter in Place

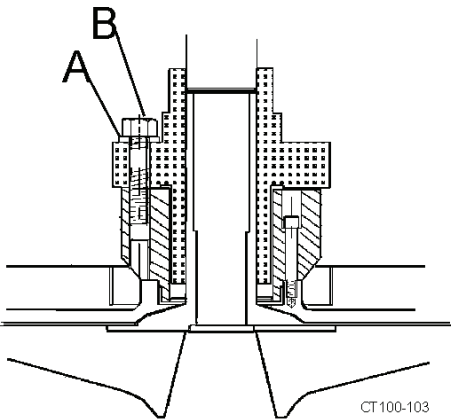

Figure 58 - Fasten Seal Unit in Place

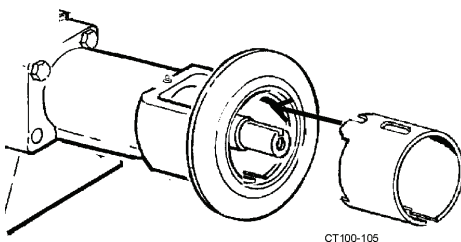

Figure 59 - Installing the Guard

1. Place the shims, backplate and impeller on the shaft assembly. Hand tighten the impeller retainer bolt on the shaft.
2. Check the impeller/backplate clearance with the backplate held firmly in position against the motor adapter. Check the space between the back of the impeller and the backplate with a feeler gauge (.030 nominal) while holding the backplate tight against the bearing housing flange. (Any axial movement of the shaft should not be added to the .030 nominal clearance). See Figure 56. If needed, change this clearance by adding or removing shims. Shims (Figure 55, item A) can be added on the drive shaft behind the impeller shaft (Figure 55, item G).
3. Confirm operating clearances by clamping the casing to the bearing housing flange and rotating the shaft/impeller manually to be sure the impeller does not touch the casing or backplate.
4. When the proper shim pack is confirmed, remove the casing, impeller and backplate, leaving the shim pack on the shaft.
5. Insert the L-gasket into the backplate. (See Figure 57, items B and C).
6. Insert the cartridge adapter (Figure 57, item A) into the backplate (item C) and tighten with four socket head cap screws.(item D).
7. Install the cartridge seal unit and use the retaining bolts (Figure 58, item B) and flat washers (Figure 58, item A) to secure the unit to the cartridge adapter. Make sure not to tighten the retaining bolts yet.



CAUTION: Be sure the removable lugs/spacers that position the rotating part of the seal in the housing are in place at this time.

8. Apply an FDA-approved anti-seize compound to the shaft.
9. Install and position the seal guard. See Figure 59.
10. Slide the impeller, backplate and seal unit onto the shaft.

NOTE: Be sure the flushing ports in the cartridge seal are positioned with the inlet toward the bottom and the outlet toward the top. (Figure 61, item C).

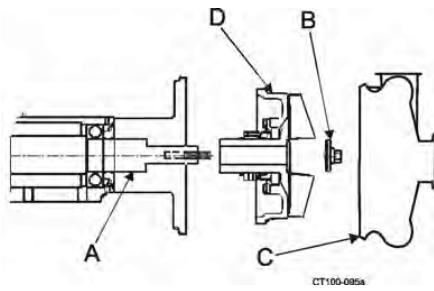

Figure 60 - Installing Impeller Assembly

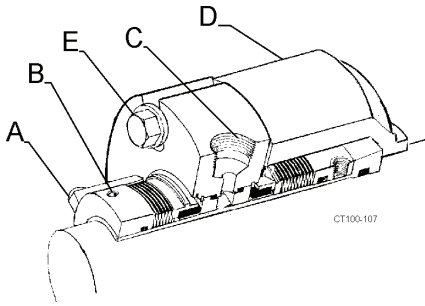

Figure 61 - Typical Cartridge Seal

Table 18: Call Outs For Figure 61

A. Lugs/Spacers	D. Seal Adapter
B. Set Screw (2)	E. Cap Screws
C. Flush Pots	

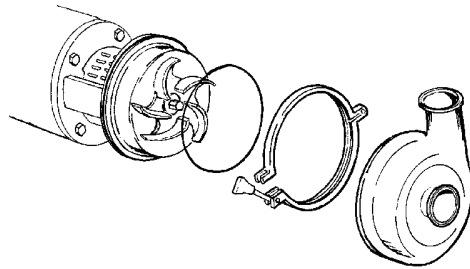

Figure 62 - Install o-ring, Casing And Clamp

11. Install the impeller key. (Figure 60, item A).
12. Install the o-ring on the impeller retainer bolt. (Figure 60, item C).
13. Install the impeller retainer nut and tighten. (Figure 60, item B).
14. Hold the backplate in place and tighten the cartridge seal into the cartridge adapter by tightening the cap screws (Figure 61, item E).

NOTE: The backplate and seal can be rotated to give access to the bolts through the holes in the guard.

15. Install the o-ring and casing; clamp in place. See Figure 62.
16. Tighten the two set screws to the shaft. (Figure 61, item B).
17. Remove the lugs/spacers. (Figure 61, item A).

NOTE: Keep the lugs/spacers to reinstall on the seal cartridge if removal is ever required.

18. Connect the flushing fluid and flood the seal.
19. Turn the shaft manually to be sure shaft rotates without the impeller hitting or binding.

Pedestal Base Mounted Pump Housing Lubrication

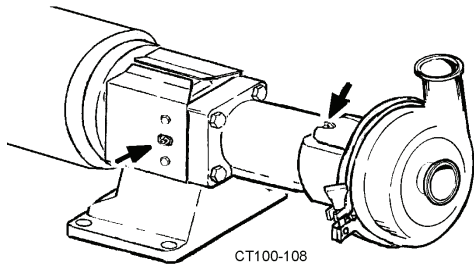

Figure 63 - Grease Fittings on the Pedestal Pump

Waukesha Series S200 Pedestal Pumps are lubricated with NLGI grade 2 Lithium Complex Grease. Use only NLGI grade 2 Lithium Complex thickened greases to replenish the bearing grease supply. The location of the grease fittings is indicated in Figure 63.

NOTE: Mixing greases that will not mix with the above products can change the viscosity/consistency of the grease resulting in bearing damage. If there is doubt remove the bearings, clean and re-pack.

For compatible lubricants, contact Waukesha Application Engineering at 1-800-252-5200 or 262-728-1900.

Lubrication Schedule

Size/RPM	Hours
Small Bore/1750 RPM	4400
Small Bore/3500 RPM	2000
Large Bore/1750 RPM	2000
Large Bore/3500 RPM	1000

NOTE: If operating temperatures are over 158°F. (70°C.) reduce hours by half for every 27°F. (15°C.) over the operating temperature.

Servicing the Electric Motor



CAUTION: Do not over-grease. Excessive lubrication may damage the unit.



WARNING: Disconnect all power sources to the unit and discharge all parts which may retain an electrical charge before attempting any maintenance or repair. Screens and covers must be maintained in place when the unit is in operation.

See the motor manufacturer's instructions for specific service information.

General Service Information

Inspect units at regular intervals.

Keep the units clean, and ventilation openings clear of dust, dirt, or other debris.

Lubricate the units per manufacturer's instructions and instruction plate on the unit.

Motor Lubrication Instructions

Some small motors have sealed-for-life bearings which require no lubrication.

Greasable bearings are shipped with a high quality wide temperature range grease in the bearings.

Some motors can be greased. Refer to the motor manufacturer's instructions for more information regarding lubrication procedures and additional service procedures.

Standard Seal Dimensions

The following seal assemblies are available with the 200 Series Pumps. These sketches provide the installed length dimension for each seal to facilitate assembly.

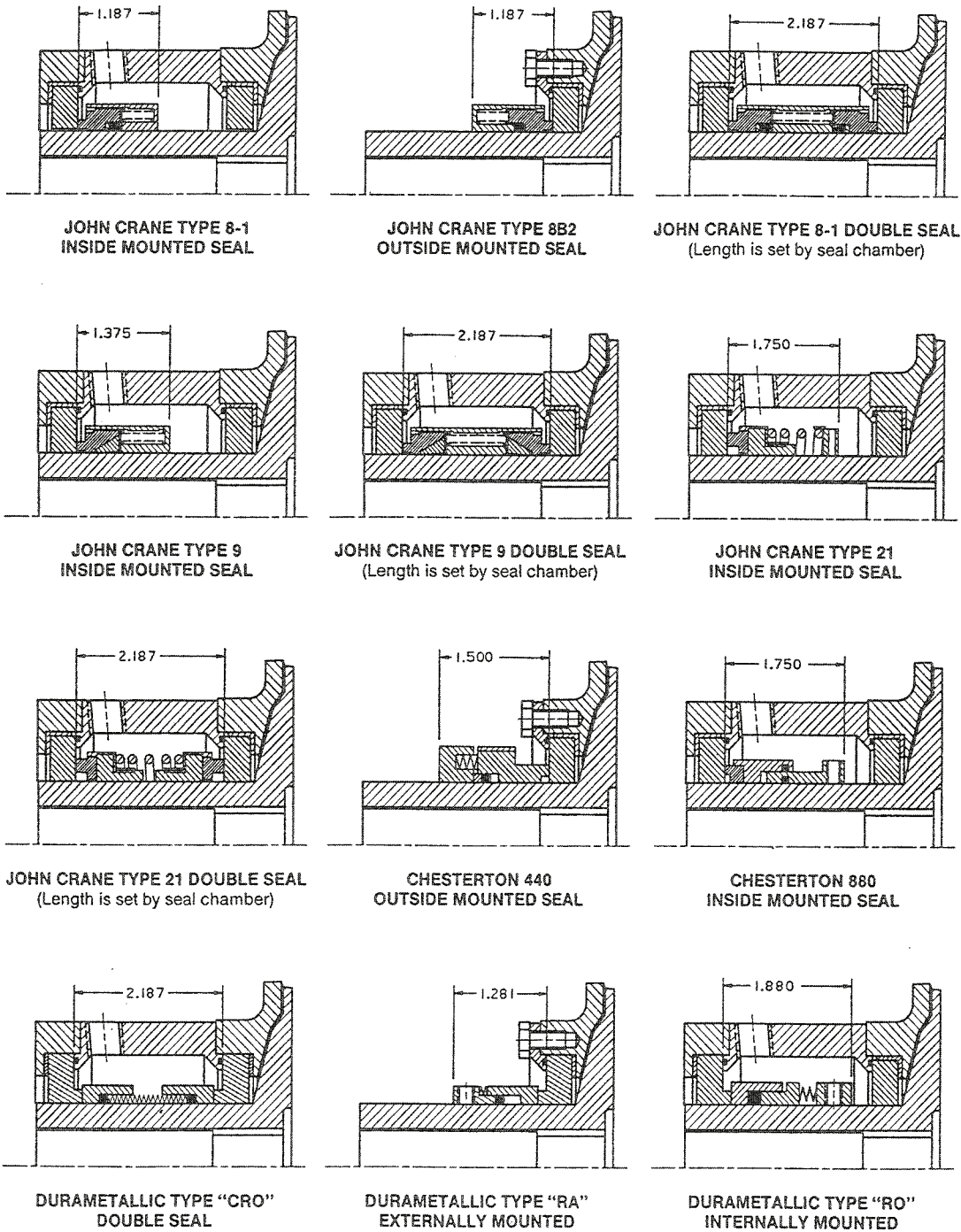

Figure 64 - Installed Seal Length (For Aid of Assembly)

Cartridge Seal Dimensions

The following pictorial list of cartridge seals is provided to assist in identifying some of the seals provided with the Model S200 centrifugal pumps. Use of these cartridges requires a cartridge seal adapter.

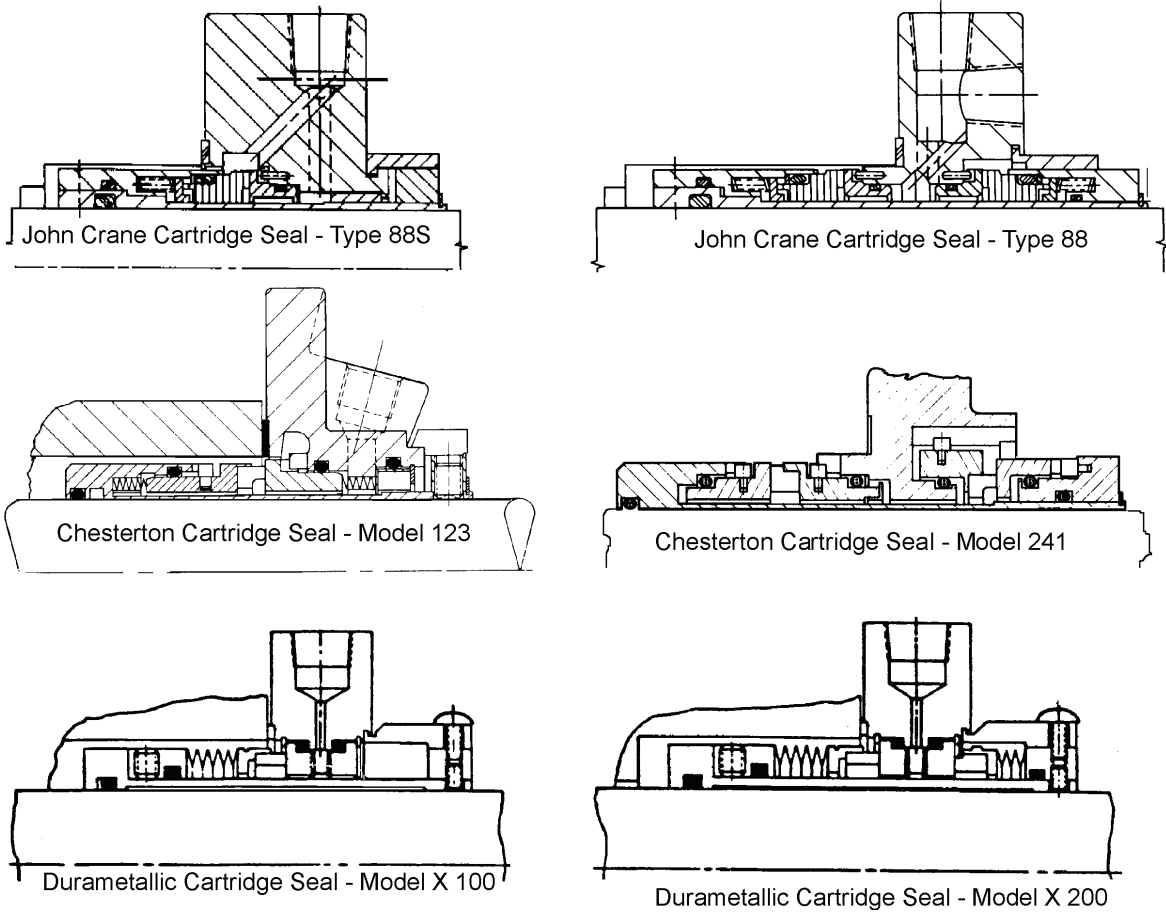

Figure 65 - Installed Cartridge Seal

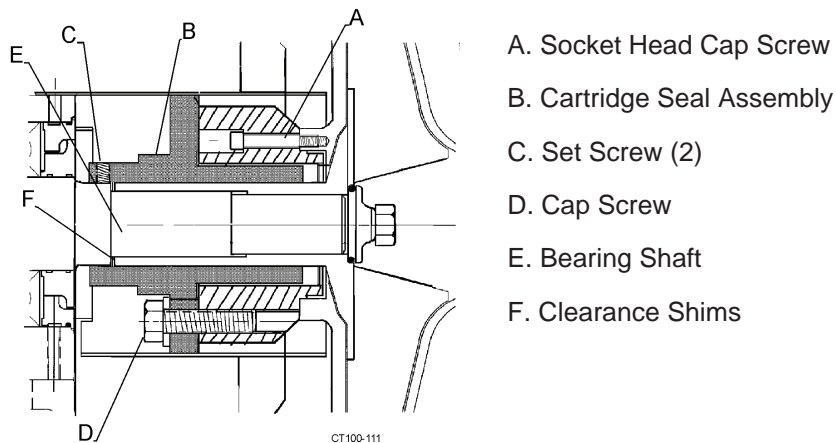

Figure 66 - Typical Cartridge Seal Installation

Parts Lists

Seal Kits

Basic Seal Kit - Type 1 Seal - Sanitary Pump Model

KIT CONTAINS	QTY	MODEL				
		S2045	S2065*	S2075	S2085*	S2092
CARBON SEAL (FKM & EPDM)	1	9-225A	9-225A	9-225A	9-225A	9-225A
SEAL O-RING (FKM)	1	V70224	V70224	V70224	V70224	V70224
SEAL O-RING (EPDM)	1	E70224	E70224	E70224	E70224	E70224
CASING O-RING (FKM)	1	V70252	V70439	V70446	V70446	V70373
CASING O-RING (EPDM)	1	E70252	E70439	E70446	E70446	E70373
IMPELLER O-RING (FKM)	1	V70214	V70220	V70220	V70220	V70220
IMPELLER O-RING (EPDM)	1	E70214	E70220	E70220	E70220	E70220
KIT ORDER # (FKM)		309-241	309-242	309-243	309-243	309-269
KIT ORDER # (EPDM)		309-241E	309-242E	309-243E	309-243E	POA

Complete Seal Kit - Type 1 Seal - Sanitary Pump Model

KIT CONTAINS	QTY	MODEL				
		S2045	S2065*	S2075	S2085*	S2092
CARBON SEAL (FKM & EPDM)	1	9-225A	9-225A	9-225A	9-225A	9-225A
SEAL O-RING (FKM)	1	V70224	V70224	9 10V	9 10V	V70224
SEAL O-RING (EPDM)	1	E70224	E70224	E70224	E70224	E70224
CASING O-RING (FKM)	1	V70252	V70439	V70446	V70446	V70373
CASING O-RING (EPDM)	1	E70252	E70439	E70446	E70446	E70373
IMPELLER O-RING (FKM)	1	V70214	V70220	V70220	V70220	V70220
IMPELLER O-RING (EPDM)	1	E70214	E70220	E70220	E70220	E70220
STATIONARY SEAL (FKM & EPDM)	1	23-17	23-17	23-17	23-17	23-17
L - GASKET (FKM & EPDM)	1	9-37	9-37	9-37	9-37	9-37
KIT ORDER # (FKM)		309-245	309-246	309-247	309-247	309-268
KIT ORDER # (EPDM)		309-245E	309-246E	309-247E	309-247E	POA

*Includes LV and HV models

Basic Seal Kit - Type 4 Seal - Sanitary Pump Model

KIT CONTAINS	QTY	MODEL				
		S2045	S2065*	S2075	S2085*	S2092
CARBON SEAL (FKM & EPDM)	2	9-225A	9-225A	9-225A	9-225A	9-225A
SEAL O-RING (FKM)	2	V70224	V70224	V70224	V70224	V70224
SEAL O-RING (EPDM)	2	E70224	E70224	E70224	E70224	E70224
CASING O-RING (FKM)	1	V70252	V70439	V70446	V70446	V70373
CASING O-RING (EPDM)	1	E70252	E70439	E70446	E70446	E70373
IMPELLER O-RING (FKM)	1	V70214	V70220	V70220	V70220	V70220
IMPELLER O-RING (EPDM)	1	E70214	E70220	E70220	E70220	E70220
HOUSING O-RING (FKM)	2	V70039	V70039	V70039	V70039	V70039
HOUSING O-RING (EPDM)	2	E70039	E70039	E70039	E70039	E70039
KIT ORDER # (FKM)		309-249	309-250	309-251	309-251	309-269
KIT ORDER # (EPDM)		309-249E	309-250E	309-251E	309-251E	POA

Complete Seal Kit - Type 4 Seal - Sanitary Pump Model

KIT CONTAINS	QTY	MODEL				
		S2045	S2065*	S2075	S2085*	S2092
CARBON SEAL (FKM & EPDM)	2	9-225A	9-225A	9-225A	9-225A	9-225A
SEAL O-RING (FKM)	2	V70224	V70224	V70224	V70224	V70224
SEAL O-RING (EPDM)	2	E70224	E70224	E70224	E70224	E70224
CASING O-RING (FKM)	1	V70252	V70439	V70446	V70446	V70373
CASING O-RING (EPDM)	1	E70252	E70439	E70446	E70446	E70373
IMPELLER O-RING (FKM)	1	V70214	V70220	V70220	V70220	V70220
IMPELLER O-RING (EPDM)	1	E70214	E70220	E70220	E70220	E70220
HOUSING O-RING (FKM)	2	V70039	V70039	V70039	V70039	V70039
HOUSING O-RING (EPDM)	2	E70039	E70039	E70039	E70039	E70039
STATIONARY SEAL (FKM & EPDM)	2	23-17	23-17	23-17	23-17	23-17
L - GASKET (FKM & EPDM)	2	9-37	9-37	9-37	9-37	9-37
KIT ORDER # (FKM)		309-253	309-254	309-255	309-255	309-270
KIT ORDER # (EPDM)		309-253E	309-254E	309-255E	309-255E	POA

*Includes LV and HV models

Class VI Elastomer Kits

MODEL	SINGLE		DOUBLE	
	FKM	EPDM	FKM	EPDM
S2045	118023	118069	118028	118074
S2065	118024	118070	118029	118075
S2075	118025	118071	118030	118076
S2085	118025	118071	118030	118076
S2092	118026	118072	118031	118077

****Class VI Elastomers are only sold as kits****

Motor Shaft Shims

MOTOR SHAFT SHIM	PART #	MOTOR NEMA FRAME SIZE	QTY.
.005" THICK	35-4	254JM-326JM	AS REQUIRED
.010" THICK	35-5	254JM-326JM	AS REQUIRED
.020" THICK	35-6	254JM-326JM	AS REQUIRED
.005" THICK	35-1	142JM-215JM	AS REQUIRED
.010" THICK	35-2	142JM-215JM	AS REQUIRED
.020" THICK	35-3	142JM-215JM	AS REQUIRED

PL5030-CH27

Seal Components All Pumps

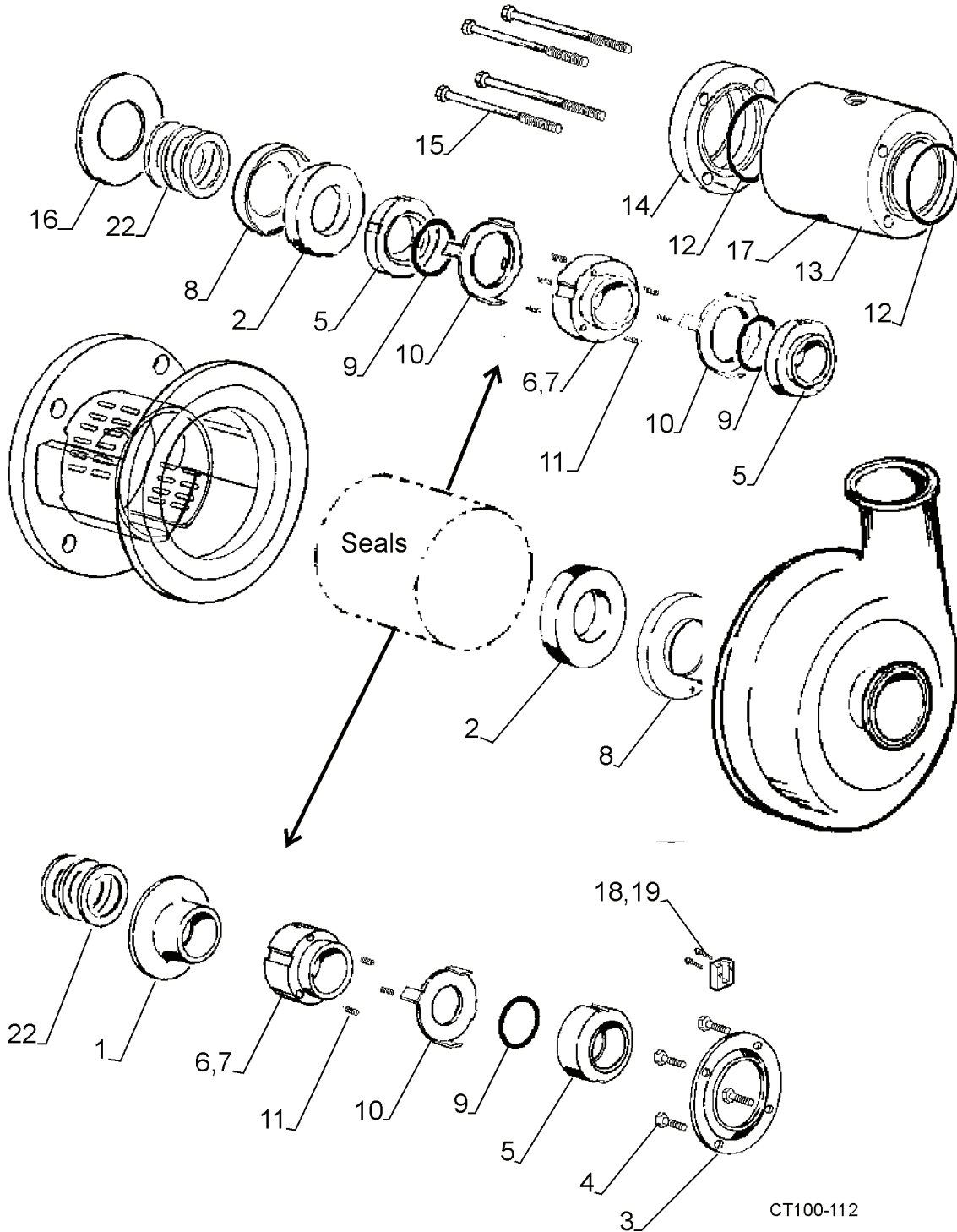

Seal Components All Pumps

ITEM #	DESCRIPTION	PART #	TYPE 1/1C SEAL QTY	TYPE 4 SEAL QTY
1	Deflector	69-1	1	-
* 2	Stationary Seal Purbide (1.75")	23-17	1	2
	Silicone Carbide (1.75")	23-17A	1	2
	Ceramic (1.75")	23-17E	1	2
	Tungsten Carbide (1.75")	23-17F	1	2
3	Seal Retainer	23-78	1	-
4	1/4 -20 x 1/2" Bolt (4 each)	30-62	4	-
* 5	Rotary Seal Carbon (1.75")	9-225A	1	2
	Purbide (1.75")	9-225B	1	2
	Silicone Carbide (1.75")	9-225C	1	2
	Tungsten Carbide (1.75")	9-225F	1	2
* 6	1/4-20 x 3/8" Set Screw (2 each)	30-178	2	1
* 7	Spring Retainer (1.75")	23-77	1	-
* 8	L-gasket FKM (1.75")	9-37	1	2
	EPDM (1.75")	9-37E	1	2
	FFKM (1.75")	9-37K	1	2
	Silicone	9-37R	1	2
* 9	O-ring FKM (1.75")	V70224	1	2
	EPDM (1.75")	E70224	1	2
	Chemrez® (1.75")	C75224	1	2
	FFKM (1.75")	K75224	1	2
	Silicone (1.75")	S75224	1	2
* 10	Washer, tabbed	43-87	1	2
* 11	Spring	24-65	3	6
* 12	O-ring, housing	V70039	-	2
13	Housing, seal	23-80	-	1
14	Retainer, seat	23-79	-	1
15	1/4-20 x 3" Cap Screw	30-175	4	4
16	Slinger, 142-215JM	69-4	-	1
17	1/4" N.P.T. Plug	78-155	-	1
18	Block, water cascade	134-2	1	-
19	8-32 x 1/4" Socket Head	30-176	2	-
20	1/4" Plastic Hose	74-1	9"	-
21	1/4" Hose Fitting	78-18	1	-

Notes

CT100-185

* Recommended spare parts

S2045 Components (Close Coupled)

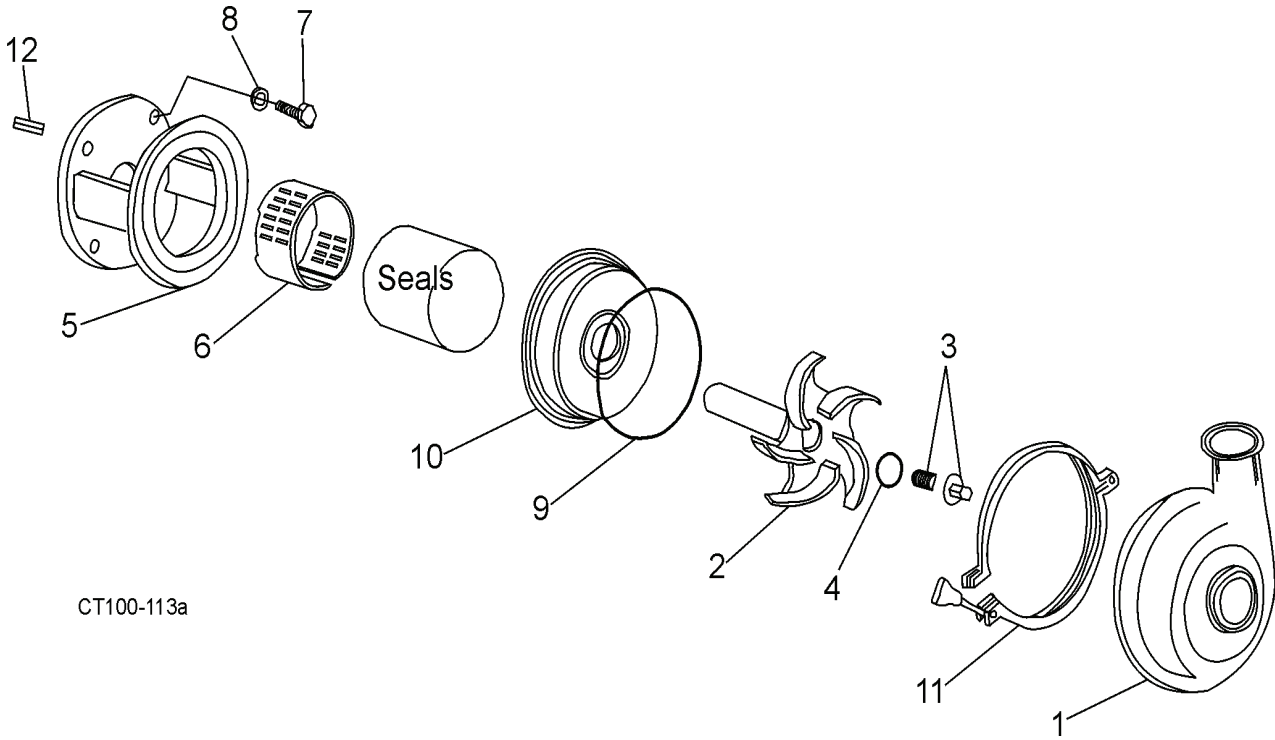

CT100-113a

ITEM #	DESCRIPTION	20RA	15RA	15RA EP	20RA EP	
1	S2045 1515 Solid Bar Casing	S-Line	CENTPT00501	CENTPT00015	CENTPT00014	CENTPT00016
		Buttweld	CENTPT00502	CENTPT00018	CENTPT00017	CENTPT00019
		150# Flange	CENTPT00503	CENTPT00021	CENTPT00020	CENTPT00022
		DIN	CENTPT00504	CENTPT00024	CENTPT00023	CENTPT00025
	S2045 2015 Solid Bar Casing	S-Line	CENTPT00501	CENTPT00027	CENTPT00026	CENTPT00028
		Buttweld	CENTPT00502	CENTPT00030	CENTPT00029	CENTPT00031
		150# Flange	CENTPT00503	CENTPT00033	CENTPT00032	CENTPT00034
		DIN	CENTPT00504	CENTPT00036	CENTPT00035	CENTPT00037
2	S2045 Impellers	Small Bore	CENTPT00702	CENTPT00703	CENTPT00704	CENTPT00447
3	S2045 (129-773X) Retainer Nut	Small Bore (142/184)	CENTPT00705	CENTPT00706	CENTPT00707	CENTPT00708
10	Backplate		CENTPT00709	CENTPT00710	CENTPT00711	CENTPT00441

CT100-186a

S2045 Components (Close Coupled)

ITEM #	DESCRIPTION	PART #	QTY	
* 4	O-ring	FKM	V70214	1
		EPDM	E70214	1
		FFKM	T80214	1
5	Adapter, motor	2-235	1	
6	Seal guard (Type 1 Seal)	70-27	1	
7	3/8-16 x 3/4" Hex screw	30-30X	4	
8	3/8" Lock washer	43-28	4	
* 9	O-ring	FKM	V70252	1
		EPDM	E70252	1
		Silicone	S75252	1
		PTFE Encapsulated	T80252	1
		FFKM	K75252	1
11	Casing clamp	119-71	1	
12	Key 3/16" 184-215JM Motor Frame	65-3	1	

Notes

CT100-186

* Recommended spare parts

S2065/S2065LV/S2065HV Components (Close Coupled)

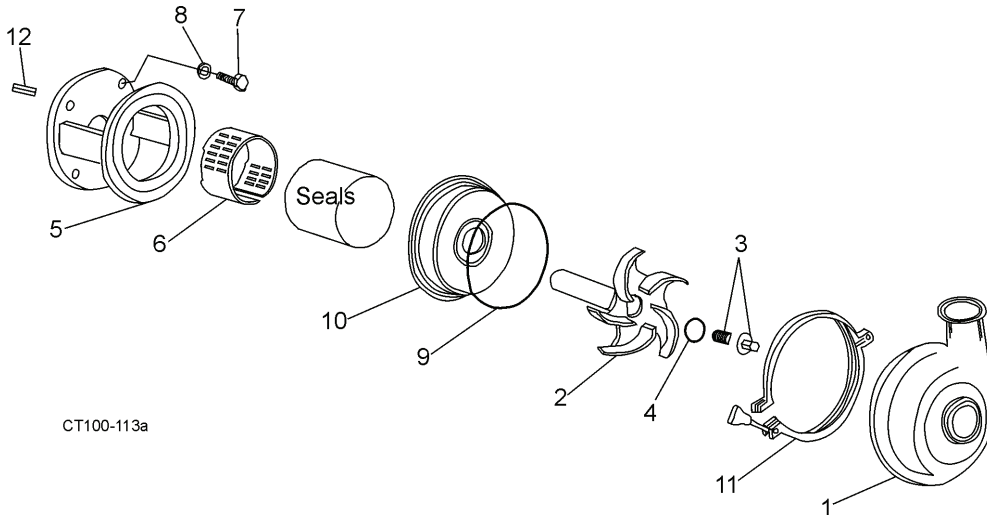

ITEM #	DESCRIPTION		20RA	15RA	15RA EP	20RA EP	
1	S2065LV 1515 Solid Bar Casing	S-Line	CENTPT00483	CENTPT00039	CENTPT00038	CENTPT00040	
		Buttweld	CENTPT00509	CENTPT00042	CENTPT00041	CENTPT00043	
		150# Flange	DIN	CENTPT00510	CENTPT00045	CENTPT00044	CENTPT00046
			DIN	CENTPT00511	CENTPT00048	CENTPT00047	CENTPT00049
	S2065LV 2015 Solid Bar Casing	S-Line	CENTPT00269	CENTPT00051	CENTPT00050	CENTPT00052	
		Buttweld	CENTPT00512	CENTPT00054	CENTPT00053	CENTPT00055	
		150# Flange	DIN	CENTPT00513	CENTPT00057	CENTPT00056	CENTPT00058
			DIN	CENTPT00514	CENTPT00060	CENTPT00059	CENTPT00061
	S2065LV 2515 Solid Bar Casing	S-Line	CENTPT00515	CENTPT00063	CENTPT00062	CENTPT00064	
		Buttweld	CENTPT00516	CENTPT00066	CENTPT00065	CENTPT00067	
		150# Flange	DIN	CENTPT00517	CENTPT00069	CENTPT00068	CENTPT00070
			DIN	CENTPT00518	CENTPT00072	CENTPT00071	CENTPT00073
	S2065 2520 Solid Bar Casing	S-Line	CENTPT00519	CENTPT00075	CENTPT00074	CENTPT00076	
		Buttweld	CENTPT00520	CENTPT00078	CENTPT00077	CENTPT00079	
		150# Flange	DIN	CENTPT00521	CENTPT00081	CENTPT00080	CENTPT00082
			DIN	CENTPT00522	CENTPT00084	CENTPT00083	CENTPT00085
	S2065HV 3020 Solid Bar Casing	S-Line	CENTPT00787	CENTPT00805	CENTPT00809	CENTPT00813	
		Buttweld	CENTPT00790	CENTPT00806	CENTPT00810	CENTPT00814	
		150# Flange	DIN	CENTPT00792	CENTPT00807	CENTPT00811	CENTPT00815
			DIN	CENTPT00788	CENTPT00808	CENTPT00812	CENTPT00816
	2	S2065LV Impellers	Small Bore	CENTPT00393	CENTPT00304	CENTPT00299	CENTPT00403
			Large Bore	CENTPT00712	CENTPT00713	CENTPT00714	CENTPT00715
		S2065 Impellers	Small Bore	CENTPT00262	CENTPT00716	CENTPT00717	CENTPT00333
			Large Bore	CENTPT00718	CENTPT00719	CENTPT00720	CENTPT00334
S2065HV Impellers		Small Bore	CENTPT00796	CENTPT00798	CENTPT00800	CENTPT00803	
		Large Bore	CENTPT00797	CENTPT00799	CENTPT00801	CENTPT00804	
3	Standard (129-771X) Retainer Nut Small Bore (143/215)		CENTPT00538	CENTPT00539	CENTPT00540	CENTPT00541	
		Standard (129-772X) Retainer Nut Large Bore (324/365TC, 254/326JM)		CENTPT00543	CENTPT00544	CENTPT00542	CENTPT00451
10	S2065LV/S2065/S2065HV Backplate		CENTPT00317	CENTPT00738	CENTPT00308	CENTPT00434	

S2065/S2065LV/S2065HV Components (Close Coupled)

ITEM #	DESCRIPTION	PART #	QTY
* 4	O-ring	FKM V70220	1
		EPDM E70220	1
		Silicone S75220	1
		FFKM K75220	1
5	Adapter	143-184JM Motor Frame 2-168	1
		213-215JM Motor Frame 2-169	1
		254-256JM Motor Frame 2-170	1
		284-326JM Motor Frame 2-196	1
6	Seal Guard (Type 1 Seal)	143-215 Motors 70-23	1
		254-256 Motors 70-24	1
		284-326 Motors 70-26	1
7	1/2-13 x 1-14" Bolt	213-256JM Motors 30-36X	4
	3/8-16 x 1" Bolt	143-184JM Motors 30-30X	4
	5/8-11 x 1-1/2" Bolt	284-286JM Motors 30-105	4
8	3/8" Lock washer	43-28	4
	1/2" Lock washer	43-16	4
	5/8" Lock washer	43-33	4
* 9	O-ring	FKM V70439	1
		EPDM E70439	1
		Silicone S75439	1
		FFKM K75439	1
11	Casing clamp	119-70	1
12	Key 3/16"	143-215JM Motor Frame 65-3	1
	Key 1/4"	254-326JM Motor Frame 65-4	1

Notes

CT100-187

* Recommended spare parts

S2075 Components (Close Coupled)

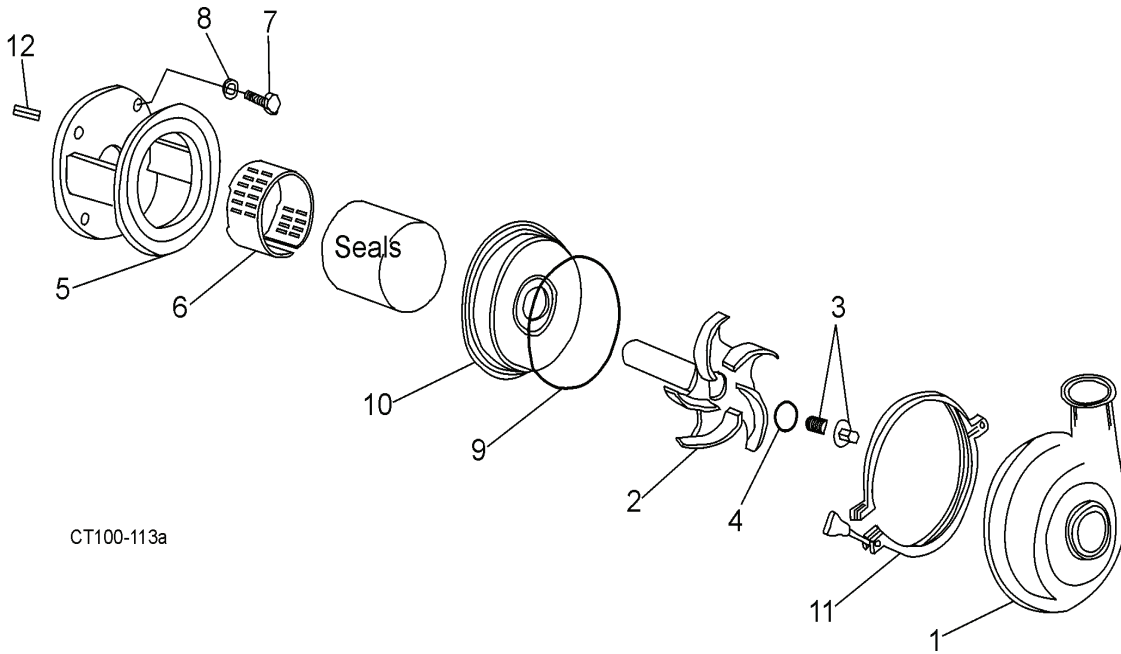

ITEM #	DESCRIPTION		20RA	15RA	15RA EP	20RA EP
1	S2075 3015 Solid Bar Casing	S-Line	CENTPT00487	CENTPT00486	CENTPT00485	CENTPT00488
		Buttweld	CENTPT00687	CENTPT00688	CENTPT00689	CENTPT00690
		150# Flange	CENTPT00691	CENTPT00692	CENTPT00693	CENTPT00694
		DIN	CENTPT00695	CENTPT00696	CENTPT00697	CENTPT00698
2	S2075 Impellers	Small Bore	CENTPT00499	CENTPT00495	CENTPT00493	CENTPT00497
		Large Bore	CENTPT00500	CENTPT00496	CENTPT00494	CENTPT00498
3	S2075 (129-771X) Retainer Nut	Small Bore	CENTPT00538	CENTPT00539	CENTPT00540	CENTPT00541
		Large Bore	CENTPT00543	CENTPT00544	CENTPT00542	CENTPT00545
10	Backplate		CENTPT00492	CENTPT00490	CENTPT00489	CENTPT00491

CT100-192

S2075 Components (Close Coupled)

ITEM #	DESCRIPTION	PART #	QTY	
* 4	O-ring	FKM	V70220	1
		EPDM	E70220	1
		Silicone	S75220	1
		FFKM	K75220	1
5	Adapter	143-184JM Motor Frame	2-171	1
		213-215JM Motor Frame	2-172	1
		254-256JM Motor Frame	2-173	1
		284JM and Larger Motor Frame	2-174	1
6	Seal Guard	143-215JM Motors	70-23	1
		254-256 JM Motors	70-24	1
		284-324JM Motors	70-26	1
		284JM and Larger Motors	114508	1
7	3/8-16 x 1" Bolt	143-184JM Motors	30-30	4
		213-256JM Motors	30-36X	4
		284JM and Larger Motors	30-105	4
8	3/8" Lock washer		43-28	4
		1/2" Lock washer	43-16	4
		5/8" Lock washer	43-33	4
* 9	O-ring	FKM	V70446	1
		EPDM	E70446	1
		Silicone	S75446	1
		FFKM	K75446	1
11	Casing clamp		119-69	1
12	Key 3/16"	143-215JM Frame Motors	65-3	1
		254-326JM Frame Motors	65-4	1

Notes

CT100-188

* Recommended spare parts

S2085/2085LV Components (Close Coupled)

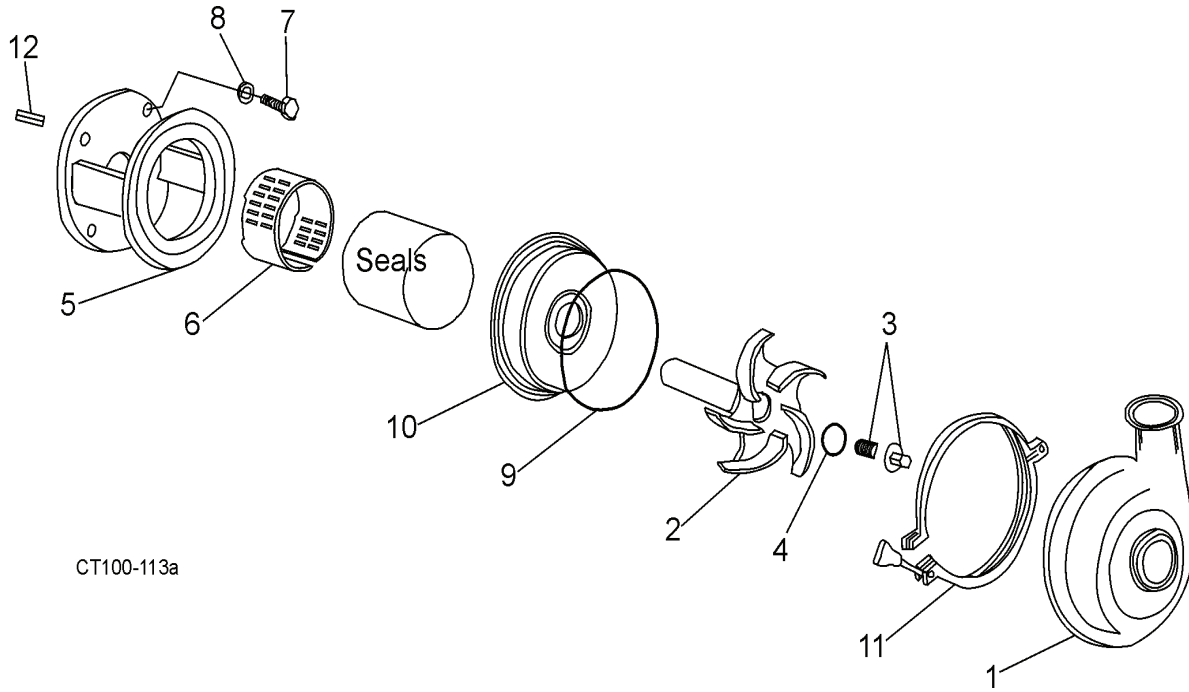

CT100-113a

ITEM #	DESCRIPTION	20RA	15RA	15RA EP	20RA EP	
1	S2085LV 2015 Solid Bar Casing	S-Line	CENTPT00300	CENTPT00087	CENTPT00086	CENTPT00088
		Buttweld	CENTPT00523	CENTPT00090	CENTPT00089	CENTPT00091
		150# Flange	CENTPT00524	CENTPT00093	CENTPT00092	CENTPT00094
		DIN	CENTPT00525	CENTPT00096	CENTPT00095	CENTPT00097
	S2085 3025 Solid Bar Casing	S-Line	CENTPT00526	CENTPT00099	CENTPT00098	CENTPT00100
		Buttweld	CENTPT00527	CENTPT00102	CENTPT00101	CENTPT00103
		150# Flange	CENTPT00528	CENTPT00105	CENTPT00104	CENTPT00106
		DIN	CENTPT00529	CENTPT00108	CENTPT00107	CENTPT00109
	S2085 4025 Solid Bar Casing	S-Line	CENTPT00530	CENTPT00111	CENTPT00110	CENTPT00112
		Buttweld	CENTPT00531	CENTPT00114	CENTPT00113	CENTPT00115
		150# Flange	CENTPT00532	CENTPT00117	CENTPT00116	CENTPT00118
		DIN	CENTPT00533	CENTPT00120	CENTPT00119	CENTPT00121
2	S2085LV Impellers	Small Bore	CENTPT00728	CENTPT00306	CENTPT00302	CENTPT00729
		Large Bore	CENTPT00730	CENTPT00731	CENTPT00732	CENTPT00733
	S2085 Impellers	Small Bore	CENTPT00721	CENTPT00722	CENTPT00723	CENTPT00724
		Large Bore	CENTPT00725	CENTPT00726	CENTPT00727	CENTPT00448
3	Standard (129-771X) Retainer Nut Small Bore (143/215)	CENTPT00538	CENTPT00539	CENTPT00540	CENTPT00541	
	Standard (129-772X) Retainer Nut Large Bore (324/365TC, 254/326JM)	CENTPT00543	CENTPT00544	CENTPT00542	CENTPT00451	
10	S2085LV/S2085 Backplate	CENTPT00739	CENTPT00740	CENTPT00741	CENTPT00430	

CT100-188a

S2085/2085LV Components (Close Coupled)

ITEM #	DESCRIPTION	PART #	QTY		
* 4	O-ring	FKM	V70220	1	
		EPDM	E70220	1	
		Silicone	S75220	1	
		FFKM	K75220	1	
5	Adapter	143-184JM Motor Frame	2-171	1	
		213-215JM Motor Frame	2-172	1	
		254-256JM Motor Frame	2-173	1	
		284JM and Larger Motor Frame	2-174	1	
6	Seal Guard	143-215JM Motors	70-23	1	
		254-256 JM Motors	70-24	1	
		284-324JM Motors	70-26	1	
		284JM and Larger Motors	114508	1	
7	3/8-16 x 1" Bolt	143-184JM Motors	30-30	4	
		1/2-13 x 1 1/4" Bolt	213-256JM Motors	30-36X	4
		5/8-11 x 1-1/2" Bolt	284JM and Larger Motors	30-105	4
8	3/8" Lock washer		43-28	4	
		1/2" Lock washer	43-16	4	
		5/8" Lock washer	43-33	4	
* 9	O-ring	FKM	V70446	1	
		EPDM	E70446	1	
		Silicone	S75446	1	
		FFKM	K75446	1	
11	Casing clamp		119-69	1	
12	Key 3/16"	143-215JM Frame Motors	65-3	1	
		Key 1/4"	254-326JM Frame Motors	65-4	1

Notes

CT100-188

* Recommended spare parts

S2092 Components (Close Coupled)

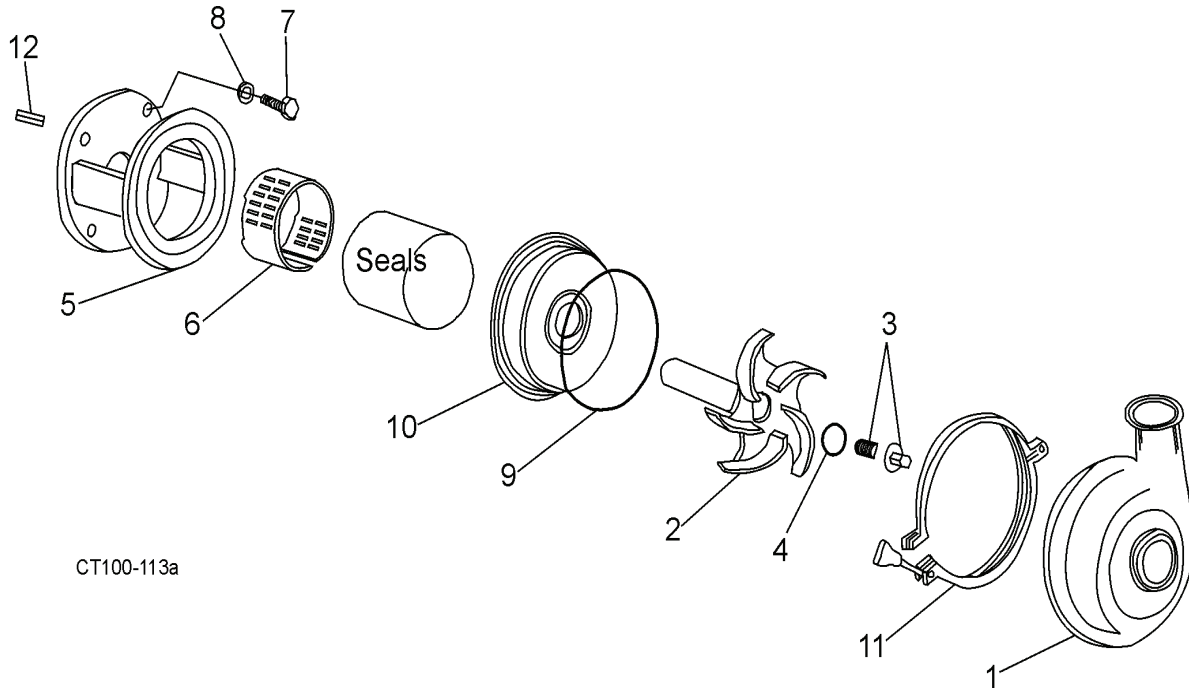

CT100-113a

ITEM #	DESCRIPTION	20RA	15RA	15RA EP	20RA EP
1	S2092 3020 Solid Bar Casing S-Line	CENTPT00534	CENTPT00123	CENTPT00122	CENTPT00124
	Buttweld	CENTPT00535	CENTPT00126	CENTPT00125	CENTPT00127
	150# Flange	CENTPT00536	CENTPT00129	CENTPT00128	CENTPT00130
	DIN	CENTPT00537	CENTPT00132	CENTPT00131	CENTPT00133
2	S2092 Impellers Small Bore	CENTPT00734	CENTPT00735	CENTPT00736	CENTPT00737
	Large Bore	CENTPT00353	CENTPT00699	CENTPT00700	CENTPT00701
3	Standard (129-771X) Retainer Nut (Kit)	CENTPT00538	CENTPT00539	CENTPT00540	CENTPT00541
	Small Bore (143/215)				
	Standard (129-772X) Retainer Nut (Kit)	CENTPT00543	CENTPT00544	CENTPT00542	CENTPT00451
10	Large Bore (324/365TC, 254/326JM)				
	S2092 Backplate	CENTPT00742	CENTPT00743	CENTPT00744	CENTPT00745

CT100-205

S2092 Components (Close Coupled)

ITEM #	DESCRIPTION	PART #	QTY		
* 4	O-ring	FKM	V70220	1	
		EPDM	E70220	1	
		Silicone	S75220	1	
		FFKM	K75220	1	
5	Adapter	143-184JM Motor Frame	2-171	1	
		213-215JM Motor Frame	2-172	1	
		254-256JM Motor Frame	2-173	1	
		284JM and Larger Motor Frame	2-174	1	
6	Seal Guard	143-215JM Motors	70-23	1	
		254-256 JM Motors	70-24	1	
		284-324JM Motors	70-26	1	
		284JM and Larger Motors	114508	1	
7	3/8-16 x 1" Bolt	143-184JM Motors	30-30	4	
		1/2-13 x 1 1/4" Bolt	213-256JM Motors	30-36X	4
		5/8-11 x 1-1/2" Bolt	284JM and Larger Motors	30-105	4
8	3/8" Lock washer		43-28	4	
		1/2" Lock washer	43-16	4	
		5/8" Lock washer	43-33	4	
* 9	O-ring	FKM	V70373	1	
		EPDM	E70373	1	
		Silicone	S75373	1	
		FFKM	K75373	1	
11	Casing clamp		119-69	1	
12	Key 3/16"	143-215JM Frame Motors	65-3	1	
	Key 1/4"	254-326JM Frame Motors	65-4	1	

Notes

CT100-193

* Recommended spare parts

Pedestal Mounted Pumps - Small Bore

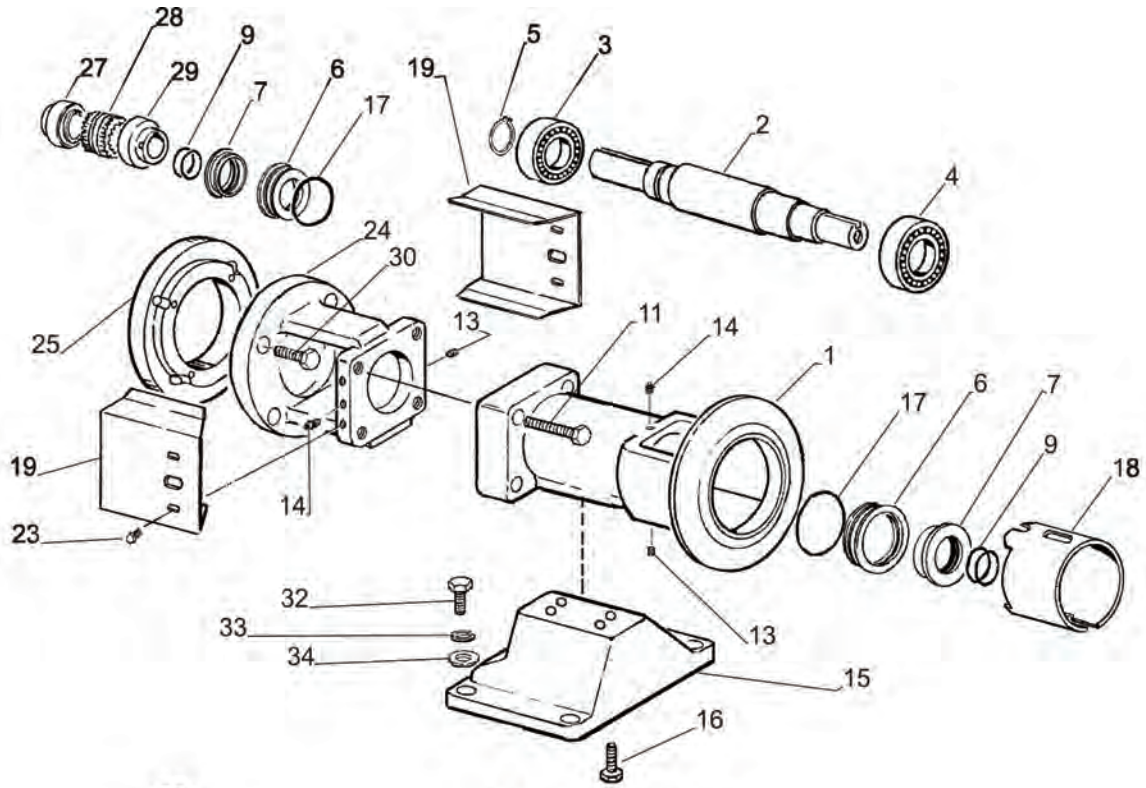

Style "B" Small Bore

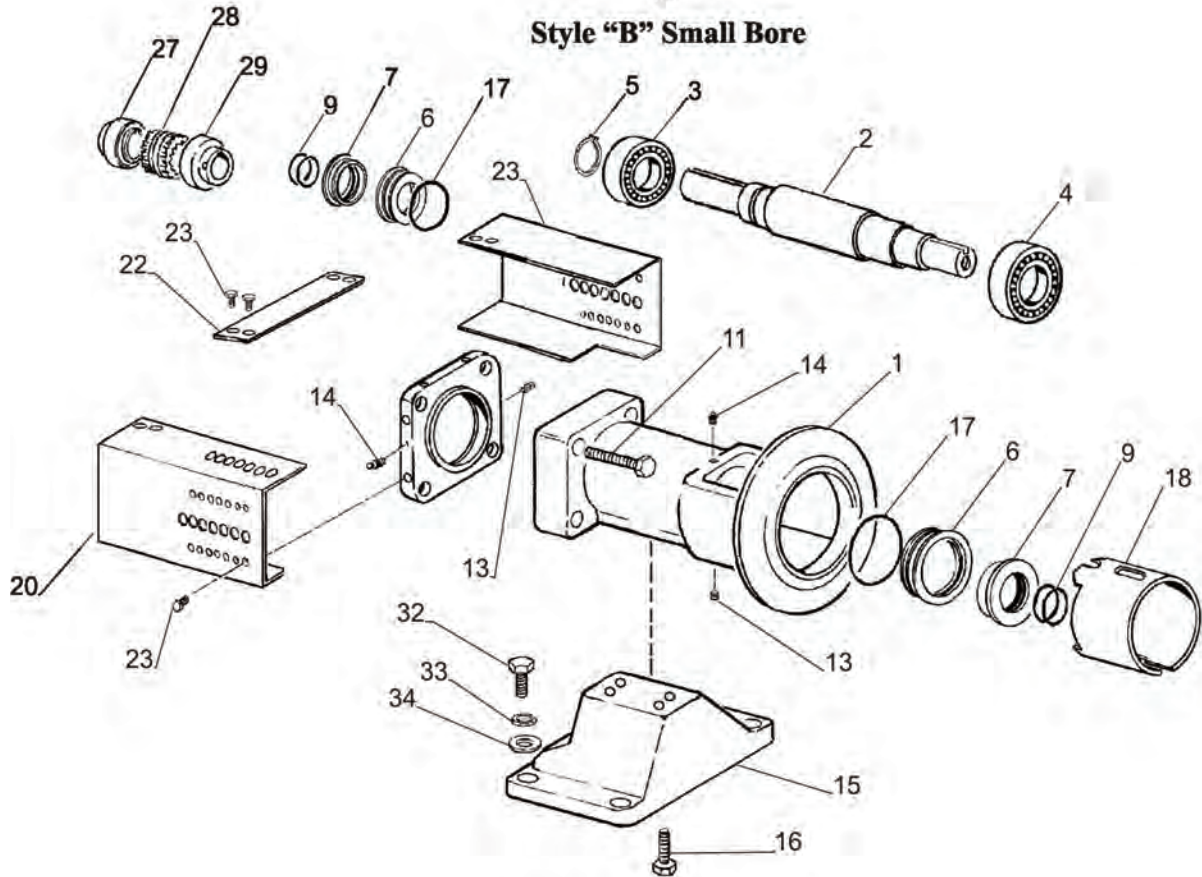

Style "C" Small Bore

Pedestal Mounted Pumps - Small Bore

ITEM #	DESCRIPTION	STYLE	MOTOR	PART #
1	Bearing housing S2045 S2065 S2075-S2085-S2092	B,C	ALL	68-6
		B,C	ALL	68-7
		B,C	ALL	68-8
2	Shaft	B,C	ALL	62-528X
3	Bearing 6309	B,C	ALL	23-101
* 4	Bearing 6209	B,C	ALL	23-100
* 5	Retaining ring	B,C	ALL	43-139
6	Seal outer	B,C	ALL	23-90
7	Seal inner	B,C	ALL	23-89
* 9	031 O-ring inner	B,C	ALL	N70031
11	HHCS 1/2-13 x 2"	ALL	ALL	30-138X
13	SHSS 1/4-20 x 3/8"	B,C	ALL	30-178
14	Grease fitting	B,C	ALL	BD0092000
15	Stand	B,C	ALL	4-34
16	HHCS 1/2-13 x 1"	B,C	ALL	30-78X
* 17	041 O-ring outer	B,C	ALL	N70041
18	Cover seal S2065-S2092 S2045	B,C	ALL	70-33
		B,C	ALL	70-32
19	Cover coupling	B	ALL	70-31
23	HHCS 1/4-20 x 1/2" LG.	B,C	ALL	30-62
24	Adapter 56C 56C 56C 182TC 182TC 182TC 182TC 182TC 182TC	B	56C	2-247
		B	143TC	2-247
		B	145TC	2-247
		B	182TC	2-248
		B	184TC	2-248
		B	213TC	2-248
		B	215TC	2-248
		B	254TC	2-248
25	Spacer adapter 213TC 213TC 254TC 254TC	B	213TC	43-134
		B	215TC	43-134
		B	254TC	43-135
		B	256TC	43-135
27	Coupling half .625 W .875 5S .875 5S 1.125 5S 1.125 5S 1.375 6S 1.625 7S	B,C	56	11-37
		B,C	143	11-101
		B,C	145	11-101
		B,C	182	11-102
		B,C	184	11-102
		B,C	213-215	33220
* 28	Coupling sleeve 4J 5JE 6JE 7JE	B,C	56	11-29
		B,C	143/184	11-30
		B,C	213/215	11-31
		B,C	254/256	11-32

Notes

CT100-189

* Recommended spare parts

Pedestal Mounted Pumps - Small Bore, cont'd

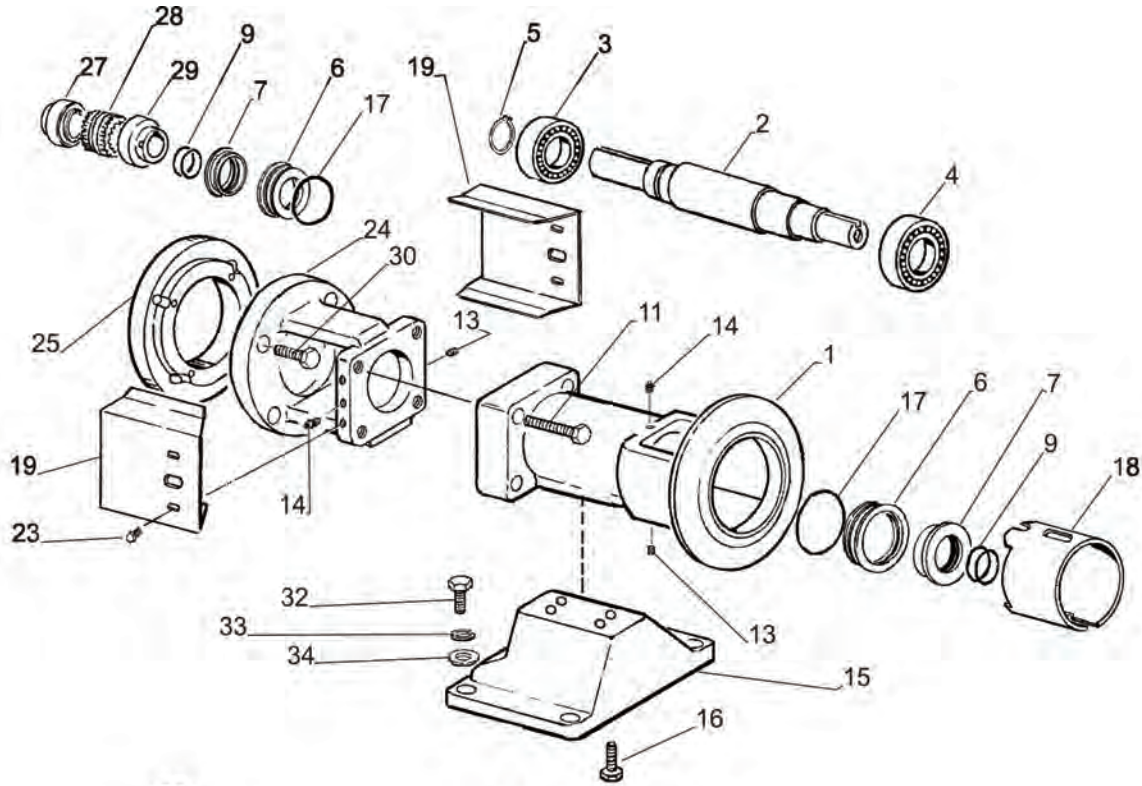

Style "B" Small Bore

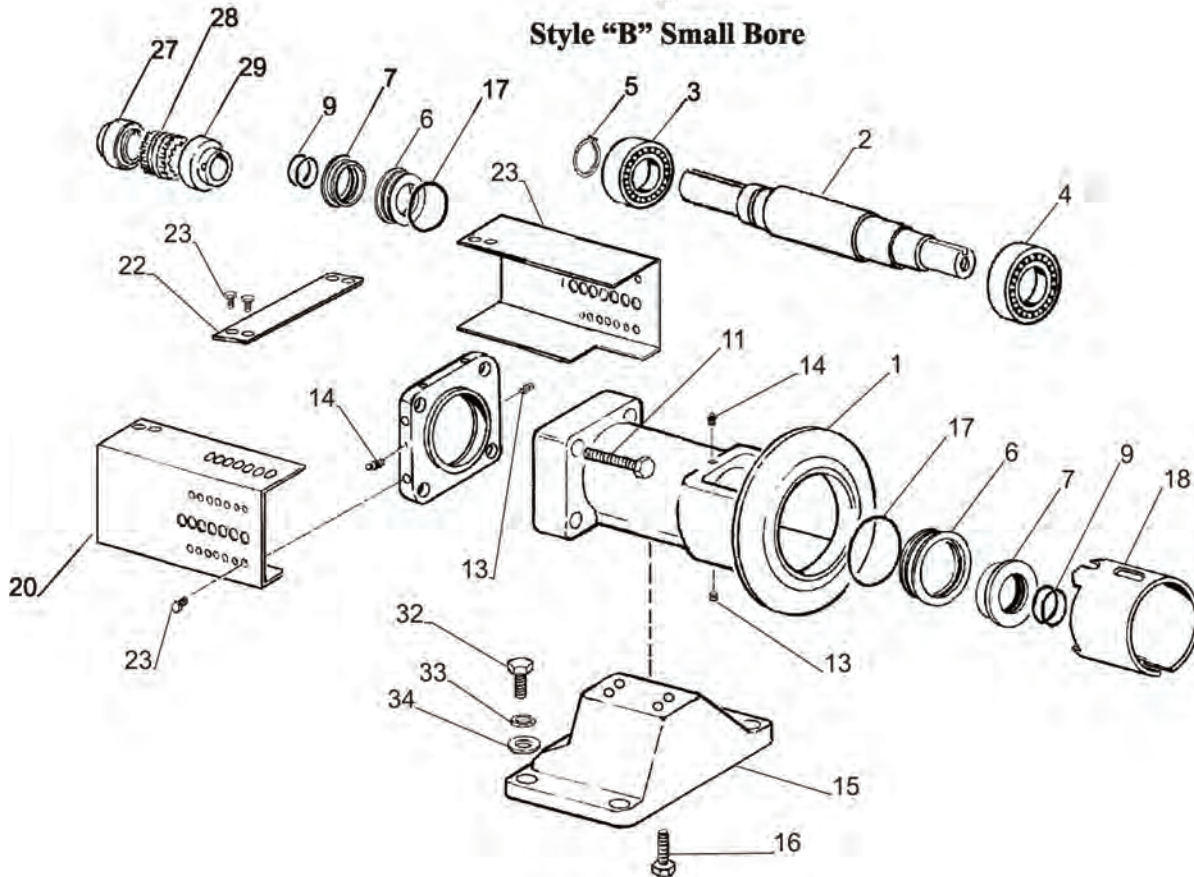

Style "C" Small Bore

Pedestal Mounted Pumps - Small Bore, cont'd

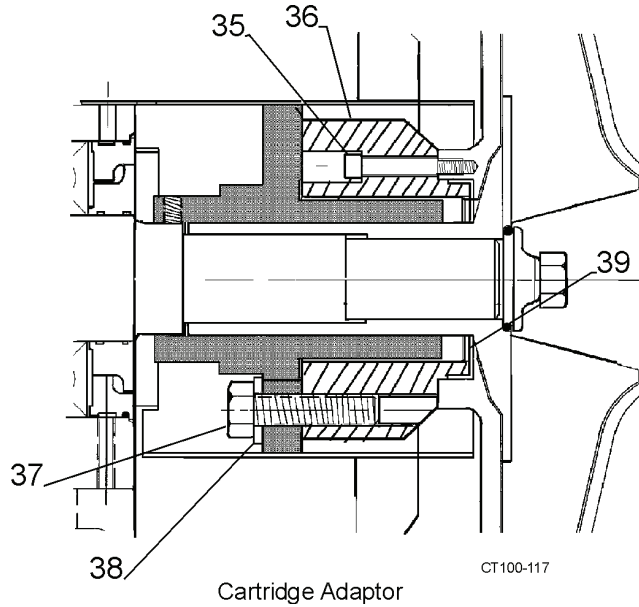

ITEM #	DESCRIPTION	STYLE	MOTOR	PART #	
29	Coupling half	1.0 4J	B,C	56	11-95
		1.0 5S	B,C	143/184	11-94
		1.0 6S	B,C	213/215	33217
		1.0 7S	B,C	254/256	33222
30	HHCS	3/8-16 x 1"	B	56/145	30-30X
		1/2-13 x 1"	B	182/184	30-78X
		1/2-13 x 1-3/4"	B	213/215	30-127X
		1/2-13 x 2-1/2"	B	254/256	30-87X
32	HHCS 1/2-13 x 1-1/2"	B,C	ALL	30-103	
33	Washer 1/2"	B,C	ALL	43-233	
34	Lock washer 1/2"	B,C	ALL	43-16	
35	SHCS 1/4-20 x 1-1/2"	B,C	ALL	30-222X	
36	Adapter, cartridge seal	B,C	ALL	23-91X	
37	HHCS 1/2-13 x 1-3/4"	B,C	ALL	30-127X	
38	Flat washer 1/2"	B,C	ALL	43-31X	
* 39	L-gasket	FKM	B,C	ALL	9-37
		EPDM	B,C	ALL	9-37E
		FFKM	B,C	ALL	9-37K

Notes

* Recommended spare parts

CT100-189a

Pedestal Mounted Pumps - Large Bore

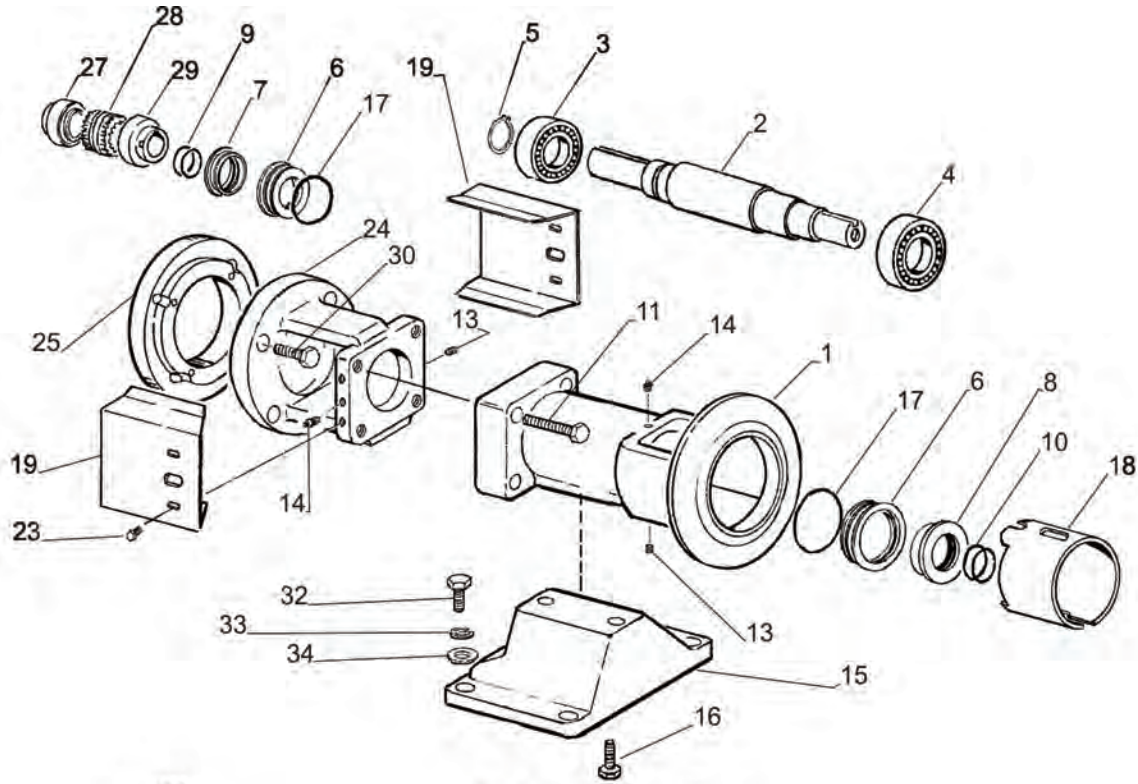

Style "B" Large Bore

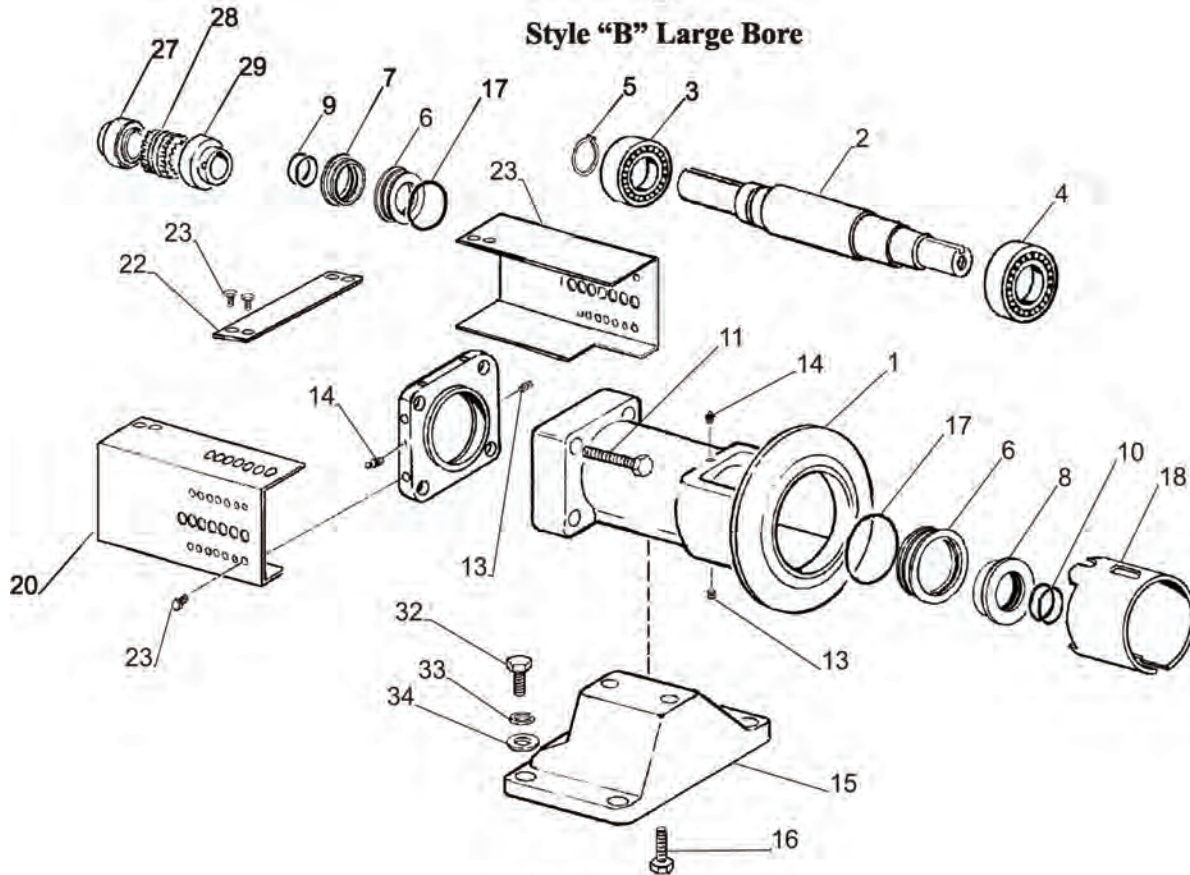

Style "C" Large Bore

Pedestal Mounted Pumps - Large Bore

ITEM #	DESCRIPTION	STYLE	MOTOR	PART #
1	Bearing housing S2065 S2075-S2085-S2092	B,C	ALL	68-9
		B,C	ALL	68-10
2	Shaft	B,C	ALL	62-539X
* 3	Bearing 5311	B,C	ALL	23-98
* 5	Retaining ring	B,C	ALL	43-138
6	Seal outer	B,C	ALL	23-95
7	Seal inner motor end	B,C	ALL	23-94
8	Seal inner motor impeller end	B,C	ALL	23-93
* 9	035 O-ring inner	B,C	ALL	N70035
* 10	033 O-ring inner impeller	B,C	ALL	N70033
11	HHCS 1/2-13 x 3-1/4"	ALL	ALL	30-221X
13	SHSS 1/4-20 x 3/8"	B,C	ALL	30-178
14	Grease fitting	B,C	ALL	BD0092000
15	Stand	B,C	ALL	4-35
16	HHCS 1/2-13 x 1-1/4"	B,C	ALL	30-36X
* 17	045 O-ring outer	B,C	ALL	N70045
18	Seal Guard S2065-S2085	B,C	ALL	70-33
19	Cover coupling adapter	B	ALL	70-34
20	Cover coupling L.H.	C	ALL	70-35
21	Cover coupling R.H.	C	ALL	70-36
22	Brace, cover coupling	C	ALL	2-252
23	HHCS 1/4-20 x 1/2" LG.	B,C	ALL	30-62
* 24	Adapter	B	213TC	2-249
		B	215TC	2-249
		B	254TC	2-249
		B	256TC	2-249
		B	284TC	2-250
		B	286TC	2-250
		B	324TC	2-250
		B	326TC	2-250
		B	364TC	2-250
25	Spacer adapter	B	254TC	43-134
		B	256TC	43-134
		B	324TC	43-136
		B	326TC	43-136
		B,C	364TC	43-137
		B,C	365TC	43-137
26	End cap housing LB	C	ALL	23-97

Notes

CT100-190

* Recommended spare parts

Pedestal Mounted Pumps - Large Bore, cont'd

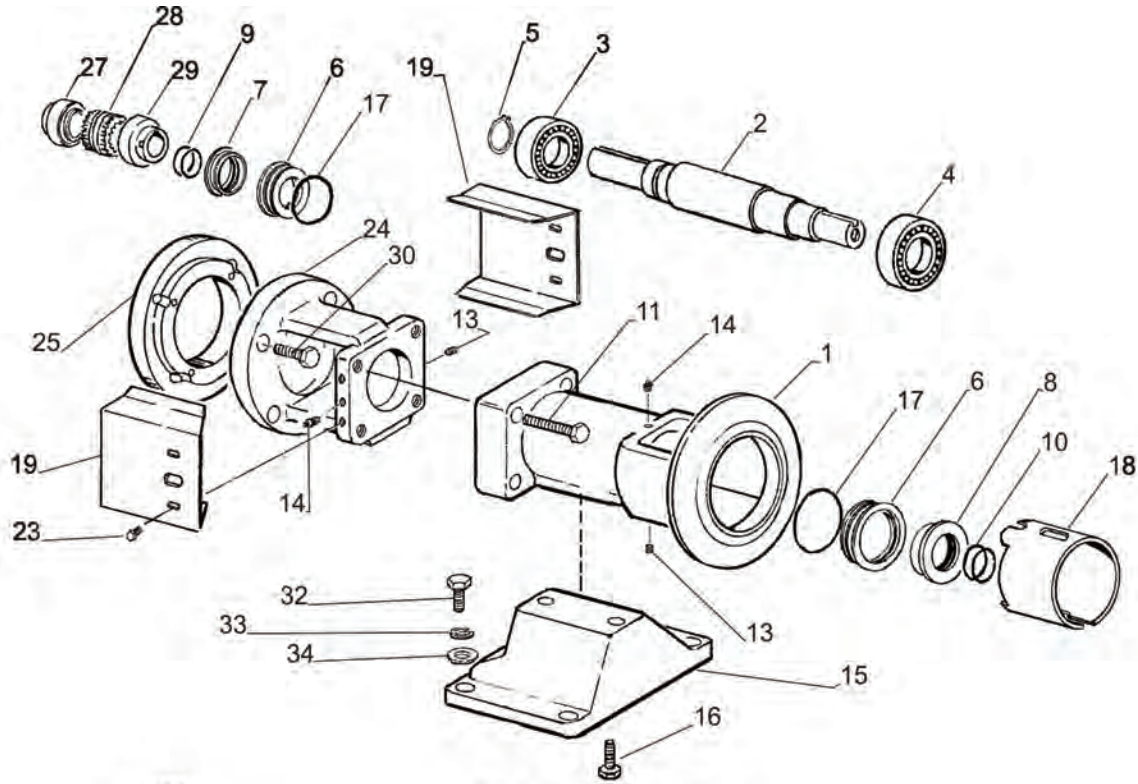

Style "B" Large Bore

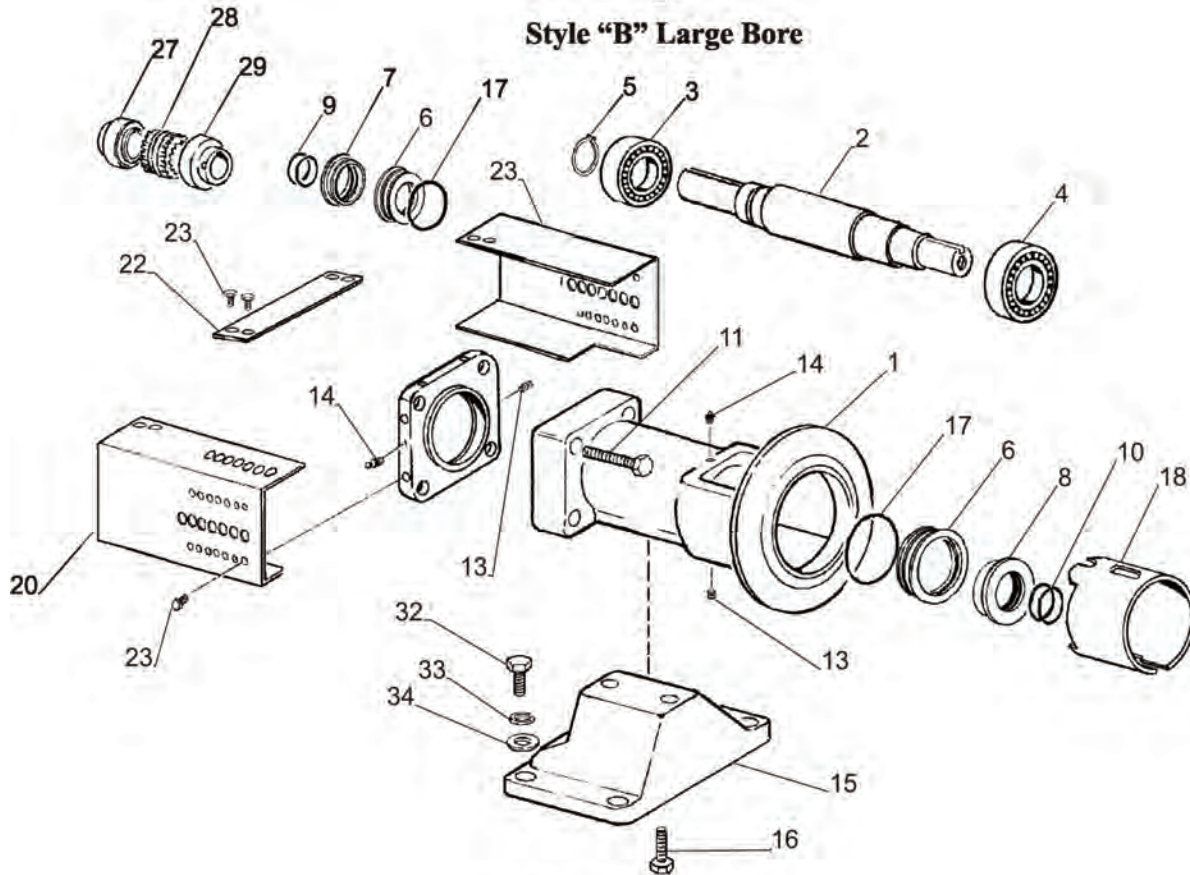

Style "C" Large Bore

Pedestal Mounted Pumps Large - Bore, cont'd

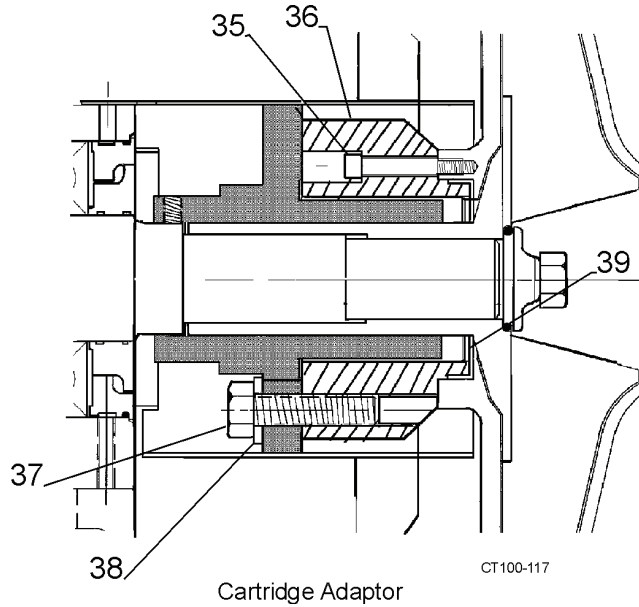

ITEM #	DESCRIPTION	STYLE	MOTOR	PART #	
27	Coupling half	1.375 6S	B,C	213-215	33220+
		1.625 7S	B,C	254-256	33227+
		1.875 7S	B,C	284/286	33229+
		2.125 8S	B,C	324-326	33237+
		2.375 8S	B,C	364	11-107
		2.375 8S	B,C	365	11-107
* 28	Coupling sleeve	6JES	B,C	213/215	11-31
		7JES	B,C	254/286	11-32
		8JES	B,C	324/326	11-33
		8HSS	B,C	364/365	33189+
29	Coupling half	1.250 6S	B,C	213/215	33219+
		1.250 7S	B,C	254/286	33224+
		1.250 8S	B,C	324/365	33230+
30	HHCS	1/2-13 x 1-1/4"	B	213/215	30-36X
		1/2-13 x 1-1/4"	B	324/365	30-21
32	HHCS 1/2-13 x 1-1/2"	B,C	ALL	30-103X	
33	Washer 1/2"	B,C	ALL	43-31X	
34	Lock washer 1/2"	B,C	ALL	43-16	
35	SHCS 1/4-20 x 1-1/2"	B,C	ALL	30-222X	
36	Adapter, cartridge seal	B,C	ALL	23-91X	
37	HHCS 1/2-13 x 1-3/4"	B,C	ALL	30-127X	
38	Flat washer 1/2"	B,C	ALL	43-31X	
* 39	L-gasket	FKM	B,C	ALL	9-37
		EPDM	B,C	ALL	9-37E
		FFKM	B,C	ALL	9-37K

Notes

* Recommended spare parts

CT100-190a

Motor Mounts

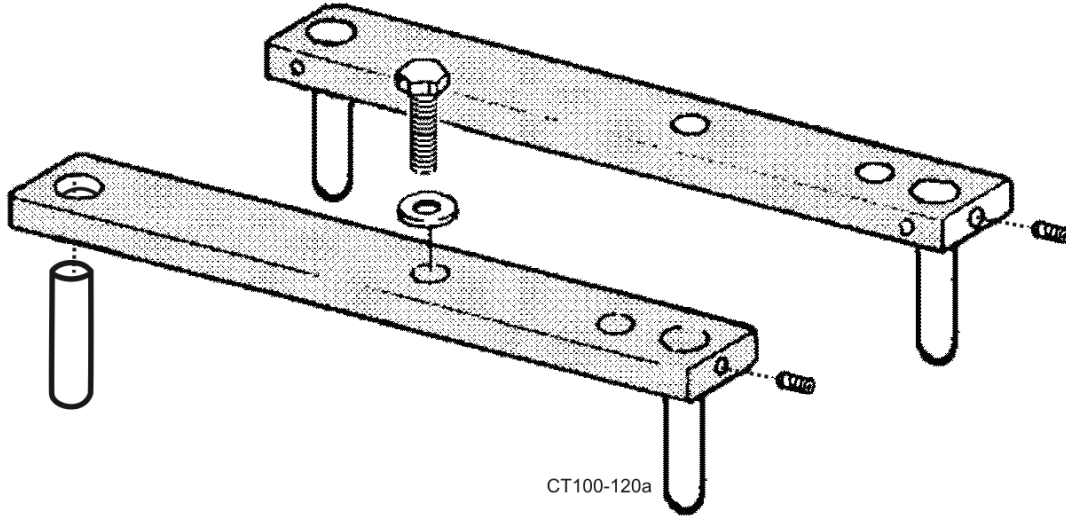

Leg Kits	
143-145JM	110256+
182-184JM	110255+
213-215JM	110254+
254-256JM	110253+
284-286JM	110252+
324-326JM	110251+

Troubleshooting

PROBLEM	POSSIBLE CAUSE	SUGGESTED ACTION
Not Enough Liquid Delivered	Pump not primed	Prime pump. Install a priming system if possible.
	Suction or discharge plugged or closed	Open suction. If plugged, shut down pump and remove blockage.
	Air leak in supply or at seal area	Check system for air leaks and repair as necessary. Replace seals if required.
	Wrong direction of rotation	Adjust motor electrical wiring to correct rotation.
	Discharge head too high	Lower discharge head requirement.
	Suction lift too high	Lower pump in system until the pump is easily supplied with material.
	Speed too slow (low voltage, wrong frequency, wrong motor)	Adjust voltage and frequency. Change motor if necessary.
	Excessive air in material	Adjust system to remove excess air from material before it reaches the pump.
Not Enough Pressure	Insufficient NPSH (Net Positive Suction Head) available	Adjust system to provide correct NPSH.
	Impeller diameter too small for duty	Contact your Waukesha Cherry-Burrell customer service representative for sizing information. WCB Customer Service 1-800-252-5200 or 262-728-1900
	Air leak in supply or at seal area	Check system for air leaks and repair as necessary. Replace seals if required.
	Wrong direction of rotation	Adjust motor electrical wiring to correct rotation.
	Speed too slow (low voltage, wrong frequency, wrong motor)	Adjust voltage and frequency. Change motor if necessary.
	Excessive air in material	Adjust system to remove excess air from material before it reaches the pump.
	Impeller diameter too small for duty	Contact your Waukesha Cherry-Burrell customer service representative for sizing information. WCB Customer Service 1-800-252-5200 or 262-728-1900
	Motor Overload	Unrestricted discharge resulting in too high a flow rate
Impeller interference		Disassemble pump and inspect for damage. Remove interference if still present. Replace worn/damaged parts.
Faulty electrical connections		Check wiring and repair/replace as necessary.

PROBLEM	POSSIBLE CAUSE	SUGGESTED ACTION
Motor Overload	Faulty electrical connections	Check wiring and repair/replace as necessary.
	Unrestricted discharge resulting in too high a flow rate	Add discharge restriction to lower flow rate.
	Impeller interference	Disassemble pump and inspect for damage. Remove interference if still present. Replace worn/damaged parts.
	Seal binding	Disassemble pump and inspect for damage. Check for material crystallization on seals.
	Discharge head too low allowing pump to deliver too much liquid	Raise discharge head until pump achieves proper resistance to flow.
	Liquid heavier or more viscous than rating	Contact your Waukesha Cherry-Burrell customer service representative for sizing information. WCB Customer Service 1-800-252-5200 or 262-728-1900
	Overload heaters too small for motor	Inspect and replace as necessary.
	Electrical supply, voltage, frequency, incorrect	Adjust voltage and frequency. Change motor if necessary.
	Impeller diameter too large for duty	Contact your Waukesha Cherry-Burrell customer service representative for sizing information. WCB Customer Service 1-800-252-5200 or 262-728-1900
	Defective motor	Replace motor.
Vibration/Noise	Pump not level	Make sure all legs are touching the floor. Level pump.
	Piping not supported	Support all piping as described in the installation section.
	Starved suction/Supply line blocked	<u>Shutdown pump</u> and remove blockage.
	Foreign material in pump	Disassemble pump, remove all foreign material and inspect for damage. Replace worn/damaged parts.
	Starved suction/Insufficient NPSH (Net Positive Suction Head) available	Adjust system to provide correct NPSH.
	Impeller hub/impeller shaft worn	Disassemble pump and inspect for damage. Replace worn parts.
	Impeller shaft loose or bent	Disassemble pump and inspect for damage.
	Impeller out of balance	Disassemble pump and inspect for damage. Replace impeller.
	Motor bearings worn	Disassemble motor and inspect for damage. Replace worn parts.

PROBLEM	POSSIBLE CAUSE	SUGGESTED ACTION
Vibration/Noise	Starved suction/supply line too long	Shorten system supply line.
	Starved suction/supply line too small	Install larger supply lines.
	Excessive air in material	Adjust system to remove excess air from material before it reaches the pump.
Rapid Seal Wear	Incorrect impeller shaft location; excessive spring loading	Adjust pump alignment to motor and piping.
	Water hammer	Adjust system to reduce air in system and sudden starts or stops in flow.
	Impeller shaft loose or bent.	Disassemble pump and inspect for damage. Replace worn/damaged parts.
	Abrasive product	Contact your Waukesha Cherry-Burrell customer service representative for sizing information. WCB Customer Service 1-800-252-5200 or 262-728-1900
	Prolonged "dry" running	Adjust process to insure pump has a continual fresh supply of product during operation.
	Abrasive solids (unfiltered) in flush water supplied to seal	Use only filtered water in seal flush system.
Seal Leaks	Gasket damaged or worn	Disassemble pump and inspect for damage.
	Seal not installed correctly	Disassemble pump and inspect seal for damage (replace if necessary). Install seal correctly and assemble pump.
	Carbon seal worn or damaged	Disassemble pump and inspect seal for damage (replace if necessary).
	Inlet/Outlet connection loose or no gasket	Inspect Inlet/outlet connection for gasket and tighten connection.
	Casing clamp loose	Tighten clamp.

Notes



Triplex Sales
1-847-839-8442
www.triplexsales.com

S200 Series

CENTRIFUGAL PUMP



SPX FLOW TECHNOLOGY

611 Sugar Creek Road

Delavan, WI 53115

P: (262) 728-1900 or (800) 252-5200

F: (262) 728-4904 or (800) 252-5012

E: wcb@spx.com

SPX reserves the right to incorporate our latest design and material changes without notice or obligation.

Design features, materials of construction and dimensional data, as described in this bulletin, are provided for your information only and should not be relied upon unless confirmed in writing.

Please contact your local sales representative for product availability in your region. For more information visit www.spx.com.

The green ">" is a trademark of SPX Corporation, Inc.

ISSUED 12/2010

COPYRIGHT ©2010 SPX Corporation

