

Shear Pump

DISPERSION EQUIPMENT

For continuous, inline and controller batch coarse processing

Processes as it pumps

Economical Waukesha Cherry-Burrell Shear Pumps combine product transfer with many involved and otherwise expensive processing operations. A completely predictable action mechanically and hydraulically produces dependable, uniform inline or batch processing with no aeration.

Versatile

Rate of flow through a controllable stator rotor arrangement, coupled with pump RPM, determines the ultimate effect on your product. No complicated adjustments are necessary. Merely select from a variety of modularly interchangeable stator and rotor combinations. Product quality control is built into the design.

Depending upon the setup you choose, you can texturize, emulsify, blend, reconstitute, suspend, disperse or polish all the time maintaining constant discharge pumping rates.

Interchange modular stators and rotors to achieve desired effect.

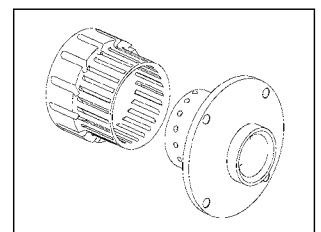
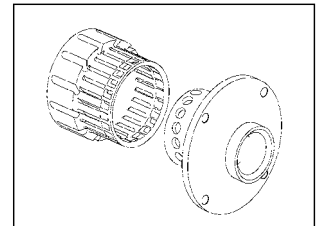
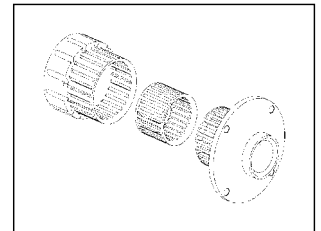

Typical Applications:

Texturizes: gives a smooth body and texture to such products as ricotta cheese and food pastes. Use of various rotor/stator combinations and/or adjustment of rotor speed provide precise control of texturizing effect.

Emulsifies: makes stable emulsions of products with both oil and water base ingredients. The requirements for stabilizer and/or emulsifier additives may be reduced.

Blends: provides continuous, online blending without air incorporation or lumps of dry product. Extremely uniform blending is achieved.

Reconstitutes: assists reconstitution of powdered products, such as milk powders. Recirculation with Shear Pump provides faster and more complete solution.

Suspends/Disperses: gives stable solids in liquid suspensions. Particle size reduction is also possible. Provides uniform dispersion of products, such as dyes.



Easy disassembly and reassembly for cleaning.

Shear Pump Dimensions:

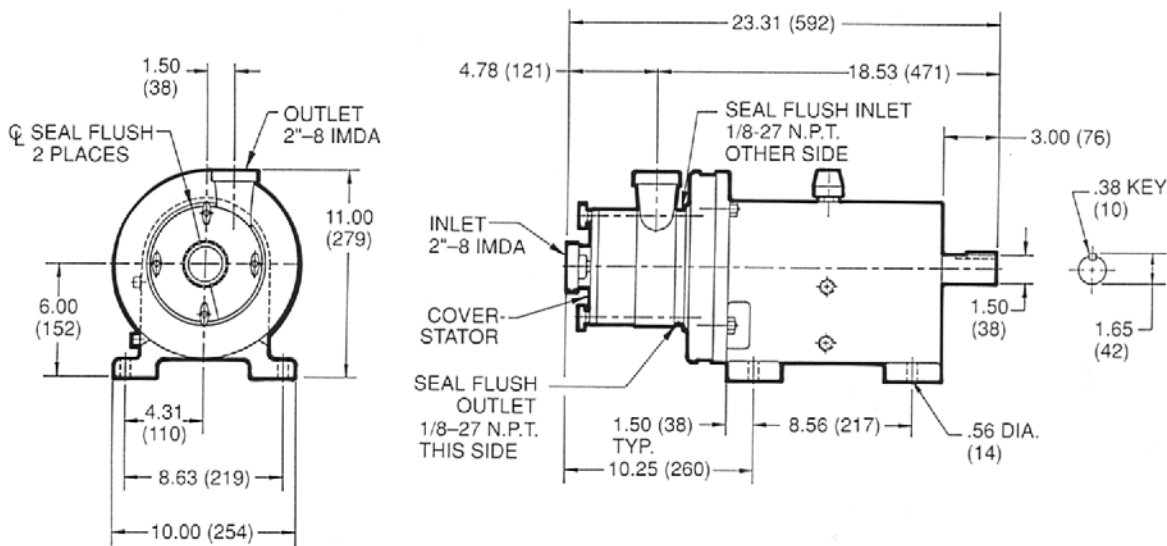

SPX

611 Sugar Creek Rd. Delavan, WI 53115

PHONE: (262) 728-1900 or (800) 252-5200 FAX: (262) 728-4904 (800) 252-5012 E-MAIL: wcb@spx.com

SPX reserves the right to incorporate our latest design and material changes without notice or obligation. Design features, materials of construction and dimensional data, as described in this bulletin, are provided for your information only and should not be relied upon unless confirmed in writing. Please contact your local sales representative for product availability in your region. For more information visit www.spx.com. The green ">" is a trademark of SPX Corporation, Inc.

ISSUED 03/2012 FH-1716 COPYRIGHT © 2012 SPX Corporation