



WANGEN AMERICA

A Business Unit of Industrial Flow North America LLC



Twin screw pump
WANGEN Twin NG

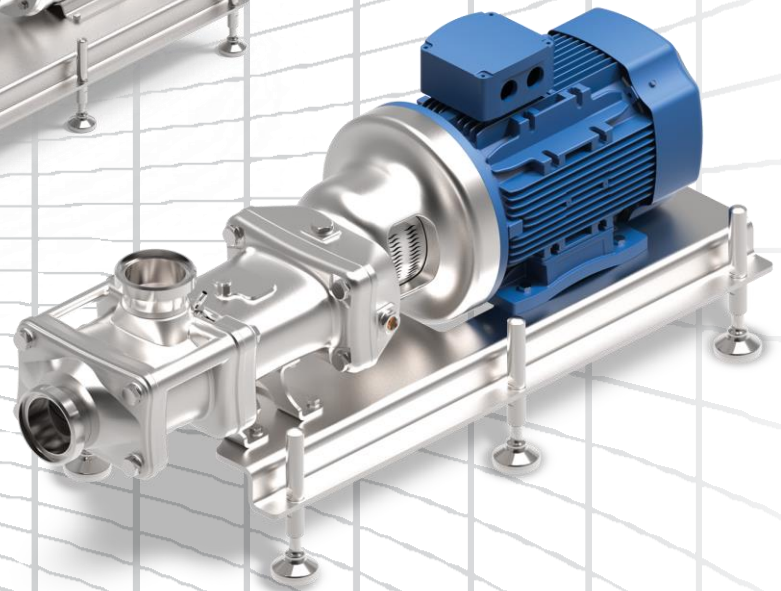
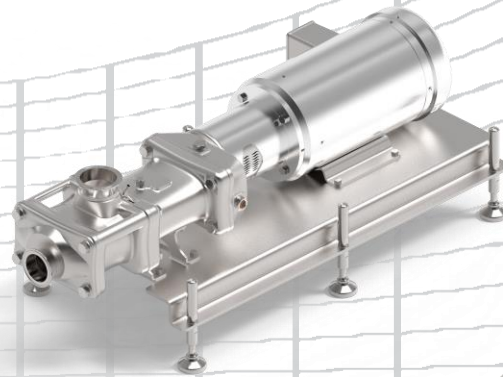

A hygienic class of its own:

**The new
generation
WANGEN Twin.**



Perfect form and technology

Maximum service friendliness

- Spindle replacement without the need to re-synchronise the spindle shafts, thanks to fast-X-change® technology, developed by WANGEN PUMPEN (see pages 4 - 5).
- Cartridge design for simple and quick seal replacement (see pages 6 - 7).
- Coupling alignment by self-centring flange housing (lantern optionally available). Therefore no need for re-alignment of the coupling, for instance after service work.

Large pressure range

16 - 25 bar / 232 - 362 psi operating pressure (depending on the pump size and design).

Advanced applicational possibilities

thanks to higher differential pressure and higher pump capacity due to extended spindle range (pitch).

Gentle pumping and CIP cleaning in a single pump

due to optimised and technically sophisticated flow behaviour (see page 8).

Maximum connection flexibility

due to a wealth of connector versions.

Simplified handling

Handles on the housing to which straps or belts can be attached.

Long service life

among other things due to the further development of the shafts.

Largest housing connectors on the market

for each respective size of housing.

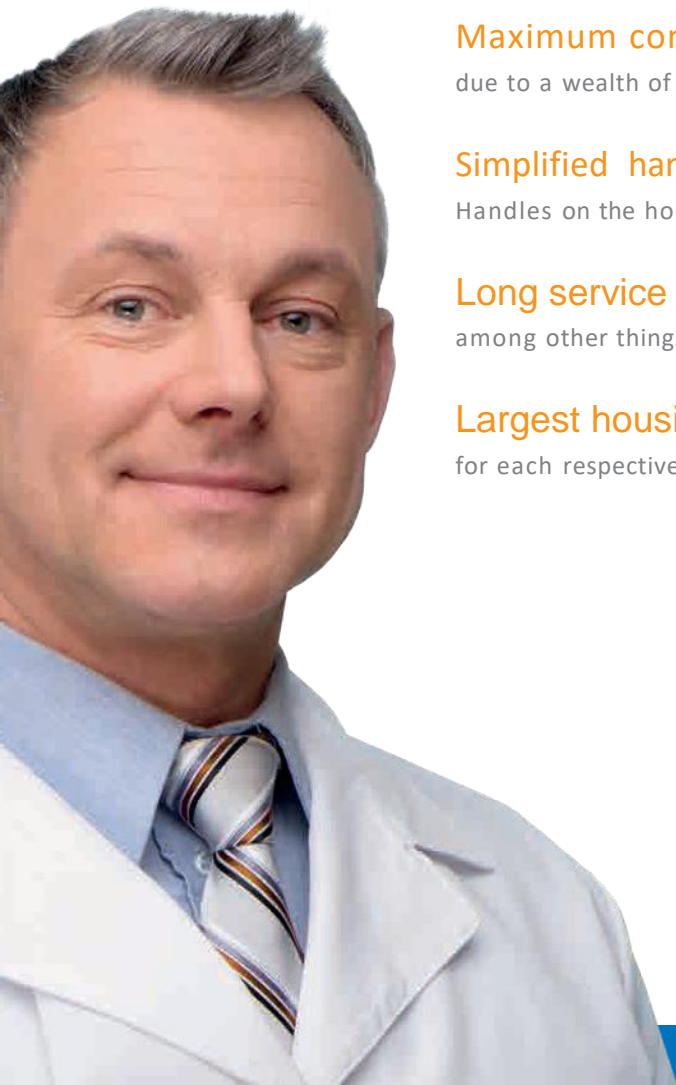

Pump media (examples)

Food:

Beverages:	pure juice, concentrate, mash, pulp, yeast.
Dairy products:	yoghurt, quark, cheese, custard, butter.
Sauces:	ketchup, mayonnaise, mustard, soup, salad dressings.
Confectionery:	chocolate, fondant, liquid sugar, rework, sugar, dough.
Fruit:	strawberries, blueberries, cherries.
Meat-based:	minced meat, roast, animal feed.

Cosmetics:

Care products:	creams, ointments, lotions.
Cleaning products:	soaps, shampoos, shower gels.

Chemical products:

Coatings:	paints, varnishes.
Bonding products:	adhesives, glues, binders.
Bases:	suspensions, solutions, additives.

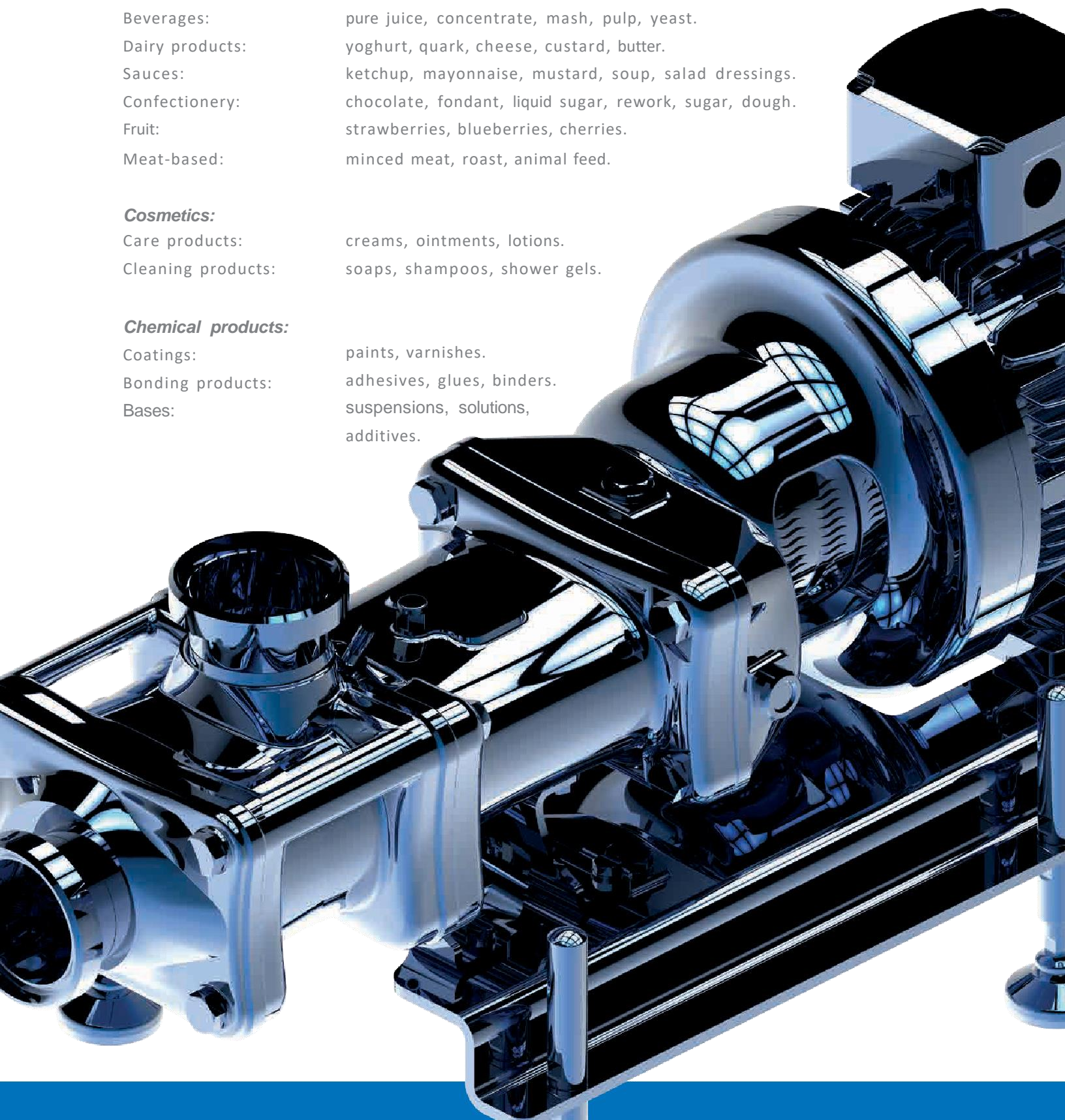

The WANGEN fast-X-change® system

Changing spindles has always involved lengthy and stressful work with conventional industry solutions, associated with time-consuming and relatively high-cost service work, as the spindles always needed to be re-synchronised. This is now a thing of the past, thanks to fast-X-change® technology, developed by WANGEN PUMPEN.

80% time savings over conventional technologies

Massively reduced working time and downtime alone Massive savings in the event of a service.

Ultra-simple spindle replacement

Spindles can now be replaced without the need to re-synchronise the spindle shaft, thanks to fast-X-change® technology, developed by WANGEN PUMPEN.

In the past, only trained personnel could re-synchronise spindles after they had been replaced. fast-X-change® technology enables the user himself to simply replace the spindle.

Prevention of error sources

Possible error sources are avoided as there is no need for re-synchronisation, further increasing the reliability of the twin screw pump. There is now also no need to drain the gear oil when changing the spindle.

Simple changeover to other media

Other pump media, other spindles. Quickly done, as the spindle can now be quickly and simply replaced.

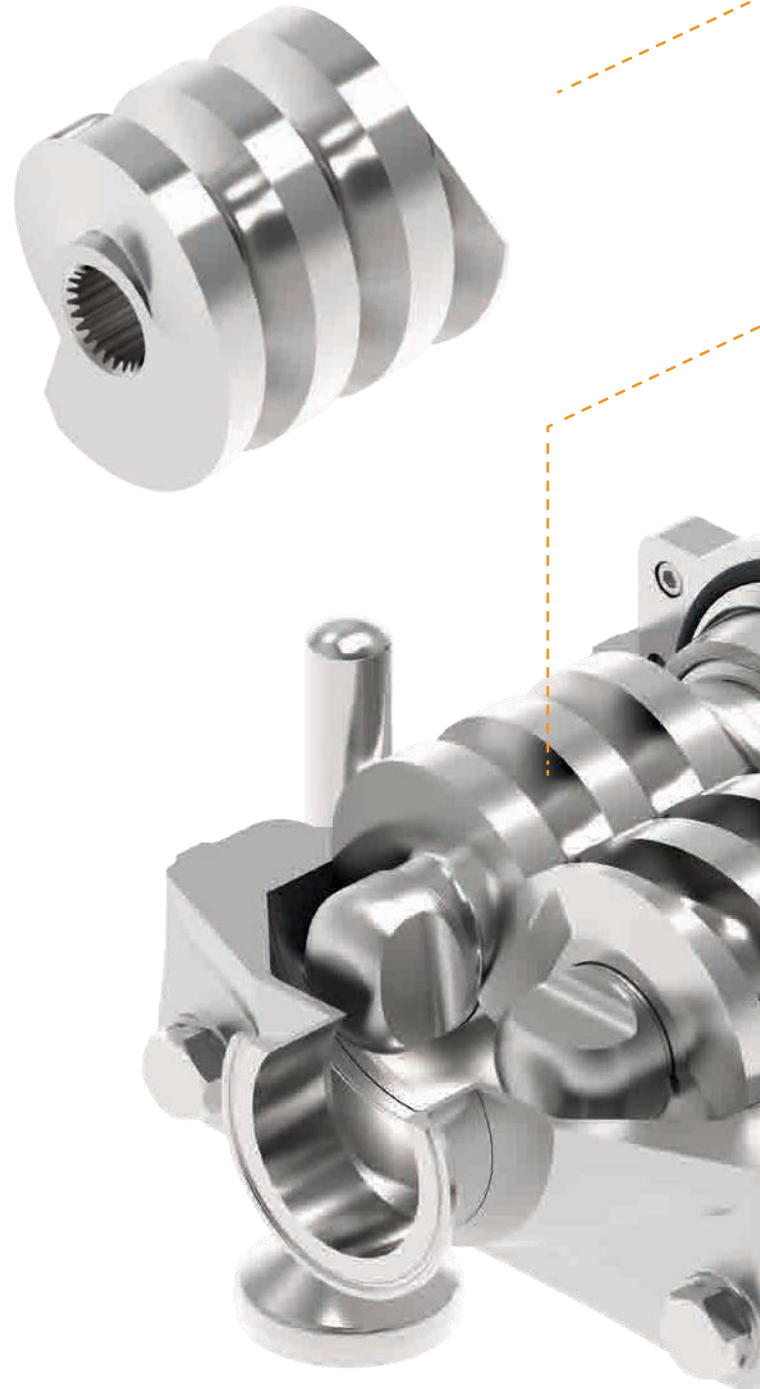

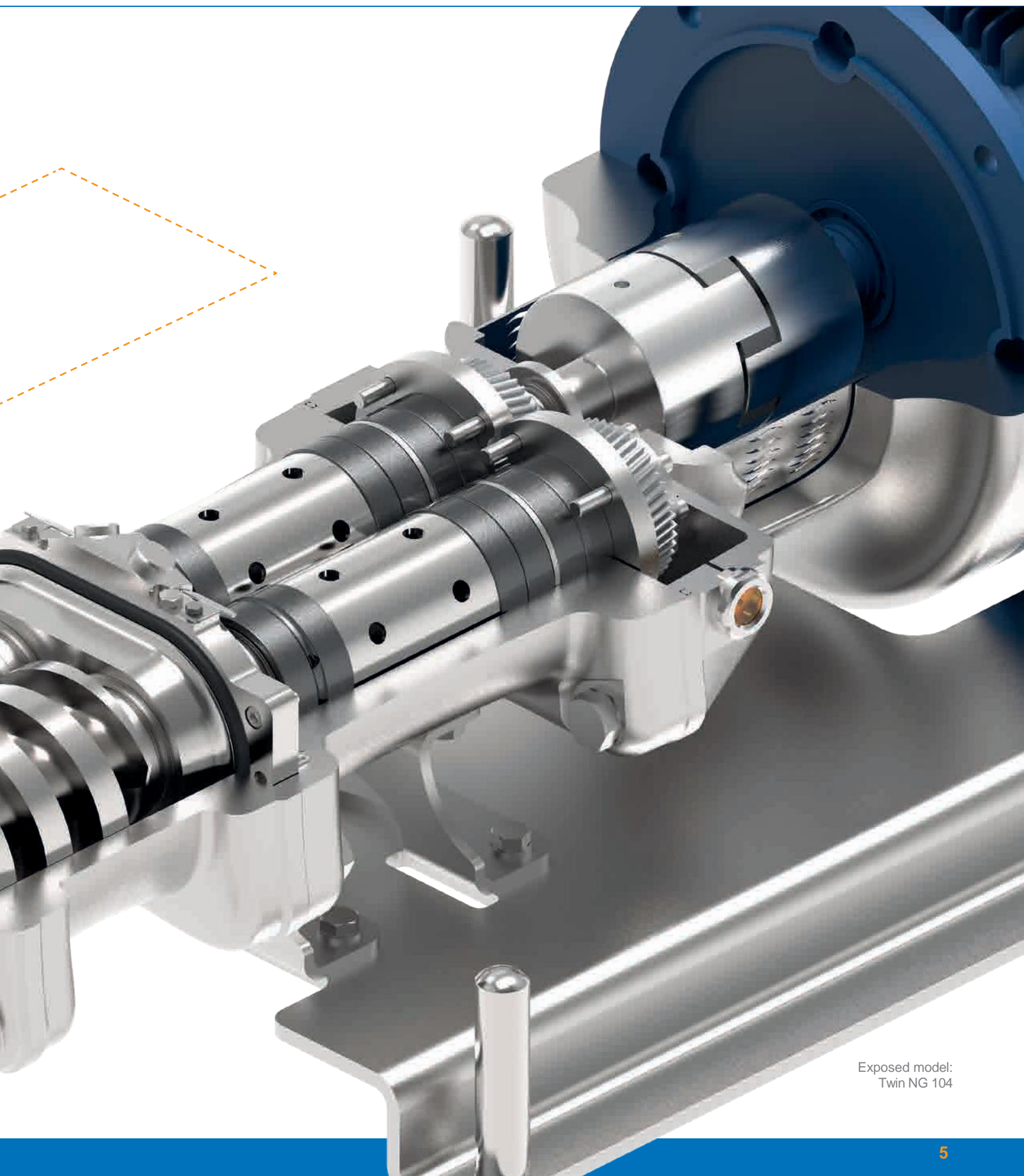

Exposed model:
Twin NG 104

Ultra-fast seal replacement

It couldn't be simpler: old seal cartridge out, new seal cartridge in. The superior design concept of the new generation WANGEN Twin is also visible here. The functionality of the seal can optionally also be restored using the WANGEN PUMPEN spare parts kit.

Maximum service friendliness

The ultimate aim with the design of the Twin NG was to achieve absolute ease of service, based on the "one step ahead" slogan. It also goes without saying that the WANGEN Twin NG simultaneously needs to meet WANGEN PUMPEN's traditionally high quality standards.

The result: the structural redesign means that the 14 individual components previously needed to replace the seal are reduced to a mere 2 components. The mechanical seal (single and dual-action) is available fully assembled as a cartridge and is simply replaced, with no time-consuming assembly of a host of single components in a certain order.

This avoids assembly-related errors as the pump is rapidly back ready for operation after a service.

One-sided dismantling is possible

The seal cartridge can be removed on the spindle side with the new WANGEN Twin NG twin screw pump. Only components in the direction of the spindles need to be removed to do so.

The time savings associated with this are also massive, with a further bonus being the fact that the cartridge can be conveniently replaced even in very compact spaces.



Single-acting cartridge-form mechanical seal of a WANGEN Twin NG 104



WANGEN AMERICA

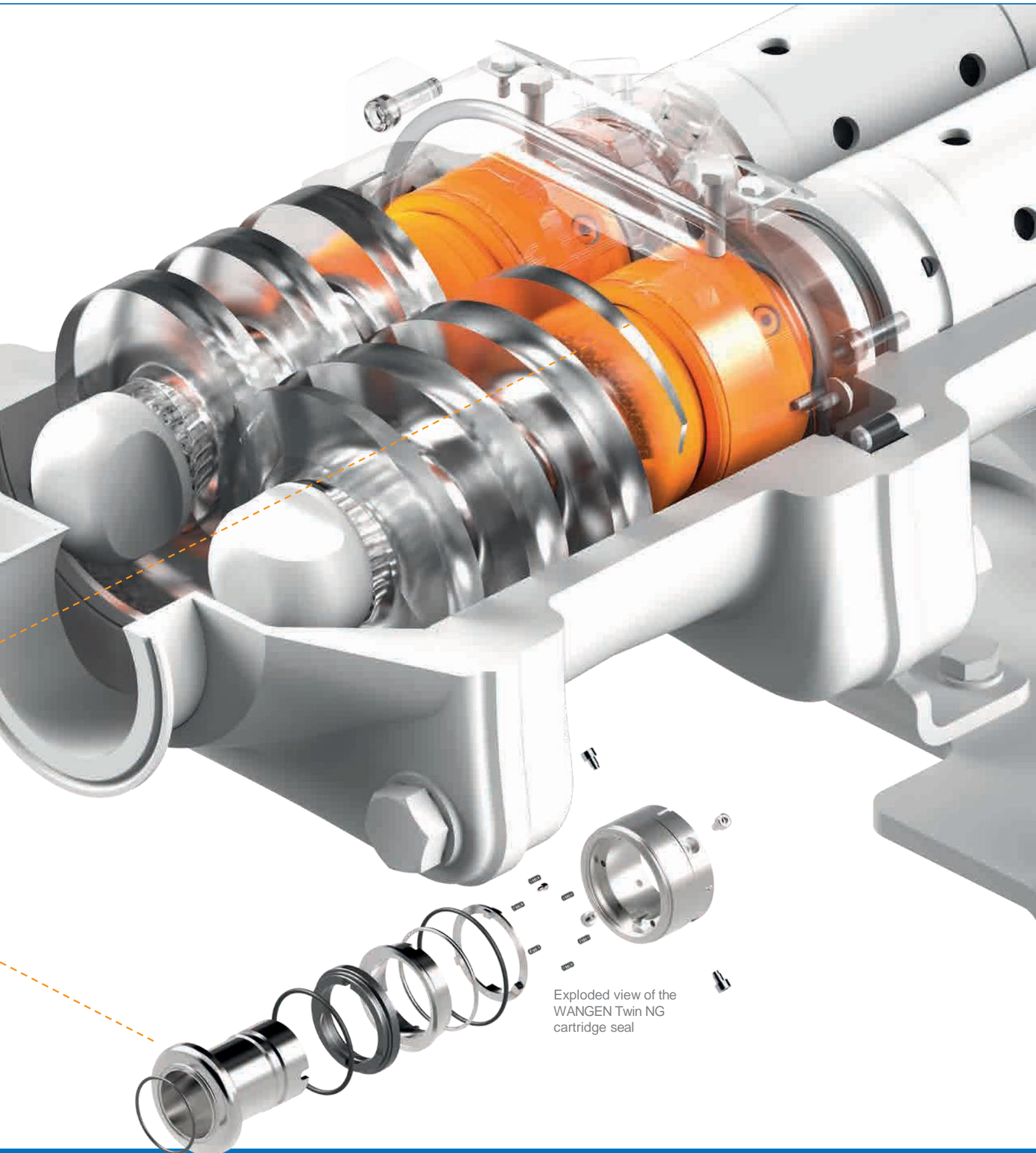

Exploded view of the
WANGEN Twin NG
cartridge seal

Two pumps in one

As with twins, you also have twice the joy with the WANGEN Twin NG: it can be used as both a product and CIP pump. You therefore have no additional costs for a separate centrifugal pump, bypass line, valves and measuring, control and regulation technology.

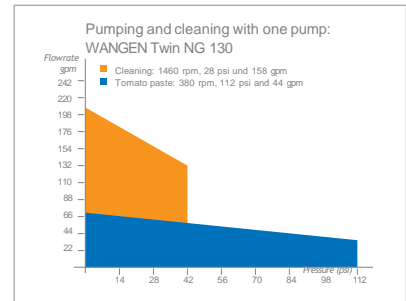
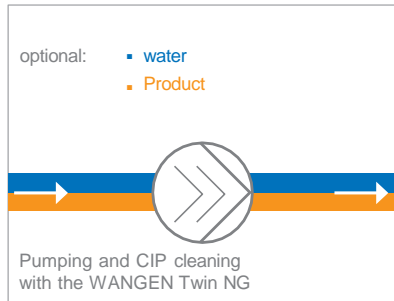
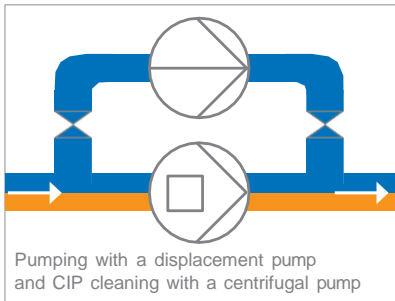

With the WANGEN Twin NG, you can add the water or cleaning medium after pumping your products and run the pump at a very high speed to clean it. The absence of a CIP backflow pump for cleaning is reflected in the procurement and operating costs,

and also solves the challenges associated with minimal or very restricted space in the production area. All components in the production line are exposed to full CIP, ensuring excellent cleaning results.



Top hygienic values

The WANGEN Twin NG achieves top marks with SIP and CIP cleaning. This is due, above all, to the following characteristics of the WANGEN Twin NG, unique in this combination:

- Extremely high speed range enables either product or cleaning fluid to be pumped
- High speeds in cleaning mode ensure self-cleaning success in the pump
- Lines, equipment and fittings filled with product can be pushed out up to a top pressure of 30 bar / 420 psi.
- Pumpenfabrik Wangen GmbH is authorised to use the 3-A label for the WANGEN Twin NG 70 3-A, 104 3-A, 130 3-A.



Other highlights

- Pump can be installed independently of the location
- 100% backward compatible with the previous WANGEN Twin generation.
- Grey cast iron bearing housing (galvanised with a high-quality coating).
- Pump available with or without direct flange attachment of the drive.
- Extended, flexible range of drives.
- Handles on the housing for ease of handling



*) applies to the WANGEN Twin NG 70 3-A, 104 3-A, 130 3-A

Characteristics

High suction lift

Axial pumping and the slow acceleration of the product in the pump ensure excellent suction performance (NPSHR < 6 ft.).

- Emptying tanks
- In the event of minimal feed height to the pump
- For the pumping of viscous or slightly simmering products

Reversible pumping direction

Pumping in both directions by reversing the rotational direction.

- When pumping and then emptying the line
- Use as a loading and unloading pump

Large viscosity range

Viscosity of up to 1,000,000 cP is possible through axial pumping and minimal kneading effect in the product. Good pumping performance thanks to high speeds even at low viscosities with 0.5 cP.

- Pumping of all low to high-viscosity products
- Pumping of the most diverse products with a single pump

60% gas proportion is possible

The high speeds also enable compressible products to be conveyed by the pump.

- When pumping and then emptying the line
- For use as a loading and unloading pump

Low-pulsation

Axial pumping and slow acceleration in the pump also ensure low pulsation. Any pulsation produced is quickly eliminated by high speeds

- Minimal shearing forces retain the structure and appearance of the products
- Ensures the gentle pumping of sensitive media
- Extension of the pump line by connection of pumps in series
- For applications requiring exacting metering precision

No risk of running dry

The contactless operation of the pump screws and flushed/ blocked mechanical seal ensure

that there is no risk of the pump running dry.

- No risk of pump failure with higher proportions of gas in the line



Twin NG 104 with standard coupling protection with variable length adjustment



Twin NG 104 with heating jacket

Spare parts

We guarantee that the performance of our pumps will be fully restored with original WANGEN PUMPEN spare parts. Our decade-long manufacturing expertise therefore offers you first-class manufacturing quality, guaranteeing the long service life of your pump.

Service hotline: +1 847 201 3121

Pump size	Maximum particle size (inch)	Maximum Flowrate (gpm) at a viscosity of 1 mPa·s	Maximum peak pressure (bar / psi)
Twin NG 70	3/4	110 (at 4000 rpm)	30 / 435
Twin NG 104	1	264 (at 3600 rpm)	30 / 435
Twin NG 130	1 1/4	440 (at 3000 rpm)	25 / 363
NEW Twin NG 180	1.5	880 (at 2600 rpm)	20 / 290



Twin NG 70

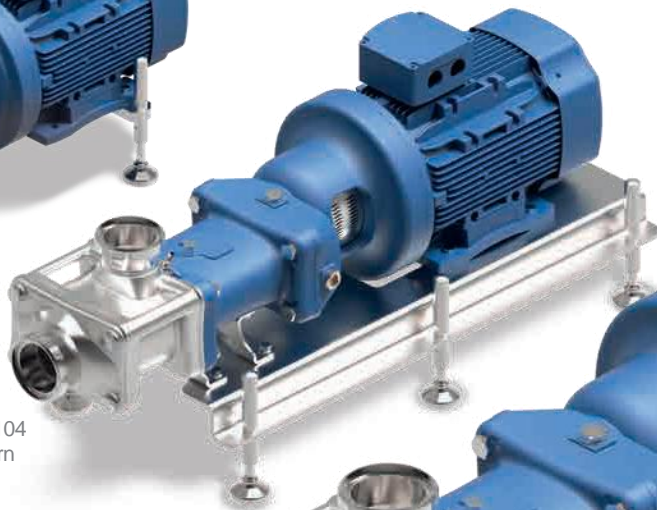

Twin NG 104 with lantern

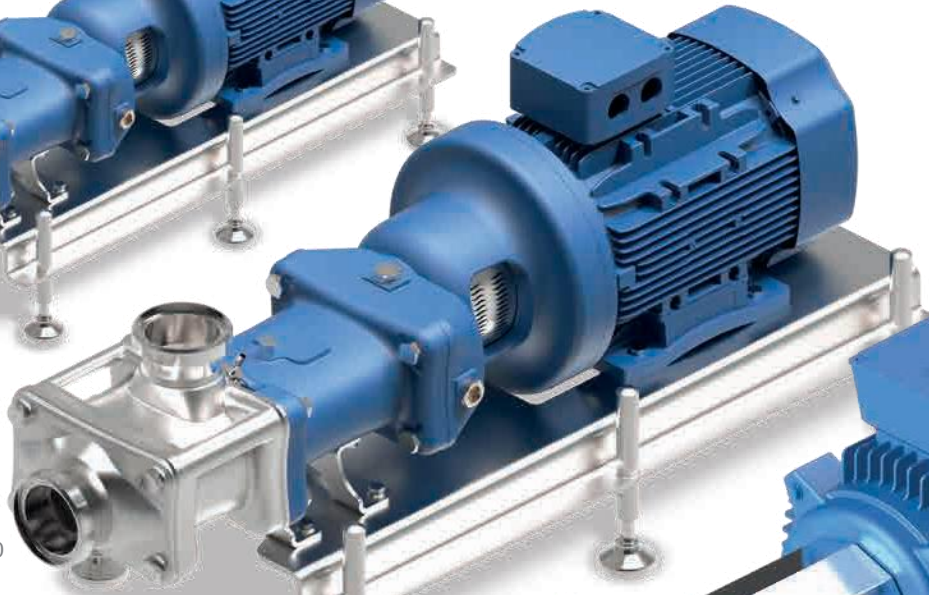

Twin NG 130 with lantern



Twin NG 70, with stainless steel cover



Twin NG 70, mobile

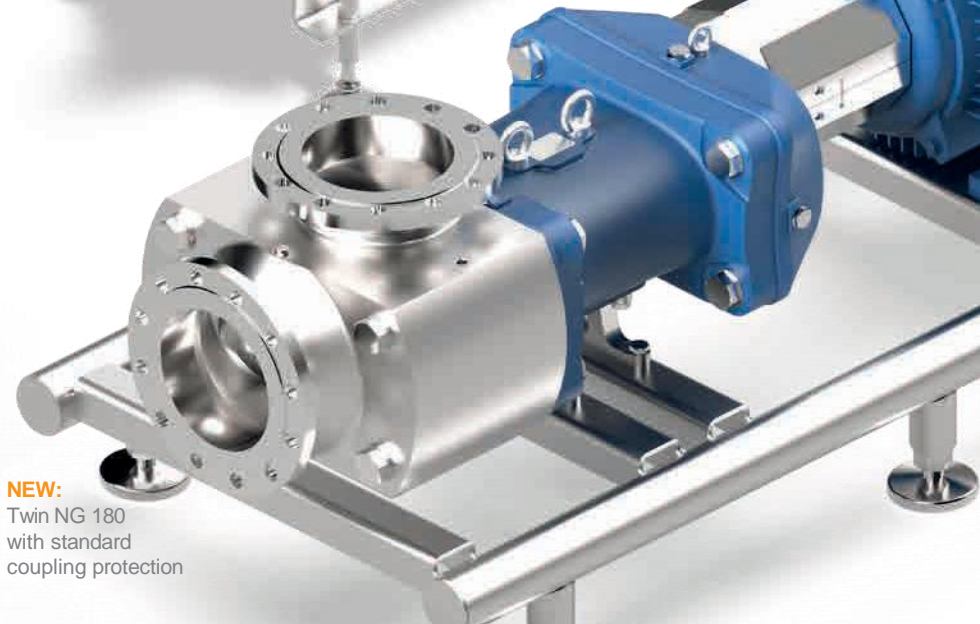

NEW:
Twin NG 180 with standard coupling protection



WANGEN AMERICA

A Business Unit of Industrial Flow North America LLC



Quality and Environmentally committed

WANGEN PUMPEN is certified according to ISO 9001 and ISO 14001.



Your contact:

Wangen America

925 Cambridge Drive
Elk Grove Village, IL
60007 USA

No. ED351

03.2024

© 2024 Pumpenfabrik Wangen GmbH. Subject to errors and technical changes.