

W-Series Mix Proof Valves

W71, W72RS, W72RSP, W73 (IN O.D. TUBING SIZES)

FORM NO.: 95-03087 REVISION: 10/2012

READ AND UNDERSTAND THIS MANUAL PRIOR TO OPERATING OR SERVICING THIS PRODUCT.





SPX Flow Technology
611 Sugar Creek Road
Delavan, WI 53115 USA

Tel: (800) 252-5200 or (262) 728-1900
Fax: (800) 252-5012 or (262) 728-4904

E-mail: wcb@spx.com
Web site: www.spxft.com

This manual is also available in an interactive PDF version online at:

http://www.spx.com/en/assets/pdf/95-03087_w70mixproofv_wcb.pdf

This interactive manual incorporates links to maintenance videos designated by this symbol



throughout the maintenance section of the manual, to help you better service your valve.

An internet connection is required for the video hyperlinks to be active.

If an internet connection is unavailable, please contact your local distributor to have a CD version ([request CD-1802](#)) of this manual shipped to you, for use without an internet connection.

This enhanced operation and maintenance manual shows you step by step videos on how to maintain your Waukesha Cherry-Burrell product.

Creating these new tools shows our commitment to provide you with the most up-to-date maintenance technology available.



DOWNLOAD
LITERATURE

Information contained in this manual is subject to change without notice and does not represent a commitment on the part of SPX Corporation. No part of this manual may be reproduced or transmitted in any form or by any means, electronic or mechanical, including photocopying and recording, for any purpose, without the express written permission of SPX Corporation.

Copyright © 2012 SPX Corporation

All Rights Reserved

Revision Date: 10/2012

Publication: 95-03087

Warranty	5
Shipping Damage or Loss	5
Warranty Claim	5
Safety	6
Care of Stainless Steel	7
Stainless Steel Corrosion	7
Elastomer Seal Replacement Following Passivation	7
Introduction	8
General Information	8
Factory Inspection	8
Models and Specifications	8
Equipment Serial Number	8
Operating Parameters	9
Seal Compatibility	9
Seat Options	10
Pressure Ratings	10
Installation	11
Location	11
Welding Instructions	11
Air Supply	11
Flow Direction	11
Fittings	12
Pipeline Support	12
Installing Valve Manifolds	12
Installing the Valve	12
Quality of Control Air to Control Module	13
External Flush - Liquid Vent Cavity	13
Liquid Vent Cavity Only	13
Liquid Vent Cavity and Lower Stem	13
External Flush - Steam Vent Cavity	14
Steam Vent Cavity, Upper and Lower Stem	14
Installation	14
Function	15
Operation	16
Solenoid Valve Port Connections	16
Automatic Fail-Safe System	17
Test Procedures	17
Positive Fail-Safe Detection Test	17
Corrective Action	18
Valve Operating Conditions	18
Valve Open	18
Valve Closed	18
Valve Closed, Upper Seat Lifted	19
Valve Closed, Lower Seat Push (for W72RS/W72RSP Series Only)	19
Valve Closed, Lower Seat Lift (for W71/W73 Series valves only)	19
Maintenance	20
Maintenance Intervals	20
Inspection	20
Lubrication	20
Cleaning	21
Cleaning-In-Place (CIP)	21
Seat Cleaning Adjustment	22
Lower seat	22
Upper seat	22
Removing Valve from System	23
Disassembly of Valve Stems	24

Adapter Bearings and O-rings	24
Inner O-ring and Bearing Replacement	24
Outer O-ring Replacement	25
Tri Ring Seat Replacement	25
Radial Seat Ring Replacement (for W72RS Lower Stem)	26
Lower Bearing Carrier O-ring and Bearing Replacement	27
Actuator O-ring and Bearing Replacement	28
Removal of O-rings and Bearings, Non-Seat Lifting Actuators	28
Removal of O-rings and Bearings, Seat Lifting Actuators	29
Installation of Piston and Spring Assembly Using Insertion Sleeve for W71/W73 4" Diameter Actuators	30
Reassembly of Valve Stems	31
Upper Stem Assembly	31
Lower Stem Assembly	31
Parts Lists	32
W71 Mix Proof Non-Seat Lift Valve	32
W71 Mix Proof Non-Seat Lift Valve with External Flush	34
W71 Mix Proof Non-Seat Lift Valve with Steam Adapter	36
W71 Mix Proof Seat Lift Valve	38
W71 Mix Proof Seat Lift Valve with External Flush	40
W71 Mix Proof Seat Lift Valve with Steam Adapter	42
W72RS Mix Proof Non-Seat Lift Valve	44
W72RS Mix Proof Non-Seat Lift Valve with External Flush	46
W72RS Mix Proof Non-Seat Lift Valve with Steam Adapter	48
W72RS Mix Proof Seat Lift Valve	50
W72RS Mix Proof Seat Lift Valve with External Flush	52
W72RS Mix Proof Seat Lift Valve with Steam Adapter	54
W72RS Mix Proof Seat Lift Valve with Upper Balancer Option	56
W72RS Mix Proof Seat Lift Tank Outlet Valve	58
W72RS Mix Proof Seat Lift Tank Outlet Valve with External Flush	60
W72RSP Mix Proof Seat Lift Valve	62
W72RSP Mix Proof Seat Lift Valve with External Flush	64
W73 Divert Mix Proof Seat Lift Valve	66
W73 Divert Mix Proof Seat Lift Valve with External Flush	68
W71 Valve Stems	70
W72RS Valve Stems	71
W72RSP Valve Stems	72
W73 Valve Stems	73
Mix Proof Valve Bodies for W71, W72RS, W72RSP, and W73 Valves	74
W71/W73 Non-Seat Lift Actuator	76
W71/W73 Seat Lift Actuator	78
W72RS Non Seat Lift Actuator	80
W72RS/W72RSP Seat Lift Actuator	82
Installation Tools	84
Troubleshooting	86

Warranty

Seller warrants its products to be free from defect in materials and workmanship for a period of one (1) year from the date of shipment. This warranty shall not apply to products which require repair or replacement due to normal wear and tear or to products which are subjected to accident, misuse or improper maintenance. This warranty extends only to the original Buyer. Products manufactured by others but furnished by Seller are exempted from this warranty and are limited to the original manufacturer's warranty.

Seller's sole obligation under this warranty shall be to repair or replace any products that Seller determines, in its discretion, to be defective. Seller reserves the right either to inspect the products in the field or to request their prepaid return to Seller. Seller shall not be responsible for any transportation charges, duty, taxes, freight, labor or other costs. The cost of removing and/or installing products which have been repaired or replaced shall be at Buyer's expense.

Seller expressly disclaims all other warranties, express or implied, including without limitation any warranty of merchantability of fitness for a particular purpose. The foregoing sets forth Seller's entire and exclusive liability, and Buyer's exclusive and sole remedy, for any claim of damages in connection with the sale of products. In no event shall Seller be liable for any special consequential incidental or indirect damages (including without limitation attorney's fees and expenses), nor shall Seller be liable for any loss of profit or material arising out of or relating to the sale or operation of the products based on contract, tort (including negligence), strict liability or otherwise.

Shipping Damage or Loss

If equipment is damaged or lost in transit, file a claim at once with the delivering carrier. The carrier has signed the Bill of Lading acknowledging that the shipment has been received from SPX Flow Technology in good condition. SPX Flow Technology is not responsible for the collection of claims or replacement of materials due to transit shortages or damages.

Warranty Claim

Warranty claims must have a **Returned Goods Authorization (RGA)** from the Seller before returns will be accepted.

Claims for shortages or other errors, exclusive of transit shortages or damages, must be made in writing to Seller within ten (10) days after delivery. Failure to give such notice shall constitute acceptance and waiver of all such claims by Buyer.

Safety

READ AND UNDERSTAND THIS MANUAL PRIOR TO INSTALLING, OPERATING, OR SERVICING THIS EQUIPMENT

Waukesha Cherry-Burrell recommends users of our equipment and designs follow the latest Industrial Safety Standards. At a minimum, these should include the industrial safety requirements established by:

1. Occupational Safety and Health Administration (OSHA), Title 29 of the CFR
Section 1910.212- General Requirements for all Machines
2. National Fire Protection Association, ANSI/NFPA 79
ANSI/NFPA 79- Electrical Standards for Industrial Machinery
3. National Electrical Code, ANSI/NFPA 70
ANSI/NFPA 70- National Electrical Code
ANSI/NFPA 70E- Electrical Safety Requirement for Employee Workplaces
4. American National Standards Institute, Section B11

Attention: Servicing energized industrial equipment can be hazardous. Severe injury or death can result from electrical shock, burn, or unintended actuation of controlled equipment. Recommended practice is to disconnect and lockout industrial equipment from power sources, and release stored energy, if present. Refer to the National Fire Protection Association Standard No. NFPA70E, Part II and (as applicable) OSHA rules for Control of Hazardous Energy Sources (Lockout-Tagout) and OSHA Electrical Safety Related Work Practices, including procedural requirements for:

- Lockout-tagout
- Personnel qualifications and training requirements
- When it is not feasible to de-energize and lockout-tagout electrical circuits and equipment before working on or near exposed circuit parts

Locking and Interlocking Devices: These devices should be checked for proper working condition and capability of performing their intended functions. Make replacements only with the original manufacturer's renewal parts or kits. Adjust or repair in accordance with the manufacturer's instructions.

Periodic Inspection: Industrial equipment should be inspected periodically. Inspection intervals should be based on environmental and operating conditions and adjusted as indicated by experience. At a minimum, an initial inspection within 3 to 4 months after installation is recommended. Inspection of the electrical control systems should meet the recommendations as specified in the National Electrical Manufacturers Association (NEMA) Standard No. ICS 1.3, Preventative Maintenance of Industrial Control and Systems Equipment, for the general guidelines for setting-up a periodic maintenance program.

Replacement Equipment: Use only replacement parts and devices recommended by the manufacturer to maintain the integrity of the equipment. Make sure the parts are properly matched to the equipment series, model, serial number, and revision level of the equipment.

Warnings and cautions are provided in this manual to help avoid serious injury and/or possible damage to equipment:



DANGER: marked with a stop sign.
Immediate hazards which WILL result in severe personal injury or death.



WARNING: marked with a warning triangle.
Hazards or unsafe practices which COULD result in severe personal injury or death.



CAUTION: marked with a warning triangle.
Hazards or unsafe practices which COULD result in minor personal injury or product or property damage.

Care of Stainless Steel

Stainless Steel Corrosion

Corrosion resistance is greatest when a layer of oxide film is formed on the surface of stainless steel. If film is disturbed or destroyed, stainless steel becomes much less resistant to corrosion and may rust, pit or crack.

Corrosion pitting, rusting and stress cracks may occur due to chemical attack. Use only cleaning chemicals specified by a reputable chemical manufacturer for use with 300 series stainless steel. Do not use excessive concentrations, temperatures or exposure times. Avoid contact with highly corrosive acids such as hydrofluoric, hydrochloric or sulfuric. Also avoid prolonged contact with chloride-containing chemicals, especially in presence of acid. If chlorine-based sanitizers are used, such as sodium hypochlorite (bleach), do not exceed concentrations of 150 ppm available chlorine, do not exceed contact time of 20 minutes, and do not exceed temperatures of 104°F (40°C).

Corrosion discoloration, deposits or pitting may occur under product deposits or under gaskets. Keep surfaces clean, including those under gaskets or in grooves or tight corners. Clean immediately after use. Do not allow equipment to set idle, exposed to air with accumulated foreign material on the surface.

Corrosion pitting may occur when stray electrical currents come in contact with moist stainless steel. Ensure all electrical devices connected to the equipment are correctly grounded.

Elastomer Seal Replacement Following Passivation

Passivation chemicals can damage product contact areas of this equipment. Elastomers (rubber components) are most likely to be affected. Always inspect all elastomer seals after passivation is completed. Replace any seals showing signs of chemical attack. Indications may include swelling, cracks, loss of elasticity or any other noticeable changes when compared with new components.



Introduction

For control top information, please refer to publication 95-03083 (2-piece) or 95-03077 (3-Piece (obsoleted)). For additional product information, please see our web site at www.spx.com/en/waukesha-cherry-burrell/resources/product-literature.

General Information

Information in this manual should be read by all personnel involved in installation, setup, operation and maintenance.

Always use installation tools and lubricants recommended by Waukesha Cherry-Burrell. Waukesha Cherry-Burrell products are subject to intensive intermediate and final leakage and functional tests.

Waukesha Cherry-Burrell Mix Proof valves meet  and  standards for sanitation, design, and style.

Double-Seat Mix Proof valves provide safe separation of dissimilar products within the same valve body. WCB offers several basic valve types:

- W71 Series for standard shut-off service
- W73 Series for divert applications
- W72RS and W72RSP Series for standard shut-off service

W72RS Mix Proof valves feature a lower radial seal for minimal spill operation when opening or closing.

Factory Inspection

Each Waukesha Cherry-Burrell valve is shipped completely assembled, lubricated and ready for use.

Models and Specifications

Materials

- Product Wetted: ASTM 316L
(UNS-S31603); (DIN-1.4404)
AL6XN upon request
- Non-Product: ASTM 304
(UNS-S30400); (DIN-1.4301)
- Elastomers: EPDM (optional)
FKM (standard)
FFKM upon request

Equipment Serial Number

Waukesha Cherry-Burrell valves are identified by a serial number found on the label on the actuator cylinder.

Operating Parameters

Temperature Range:

The recommended operating temperature is determined by the material used for the seals.

No special precautions are required for applications within a temperature range of 32°F to 180°F (0°C to 82°C).

For applications above 190°F (88°C), clearances can be affected by excessive thermal expansion when the valve is installed in compact fabrications or manifolds. Valve bodies have thicker cross-sections than tubing, but thermal expansion can affect clearances in interconnecting piping sections.

If operating below 32°F (0°C):

- Control air must have an appropriately low dew point.
- Valve stems must be protected from icing to ensure long working life for valve stem seals.

Solenoid valves may not be used in the control module in room environments below 32°F (0°C) and over 140°F (60°C), as function cannot be guaranteed.

Seal Compatibility

Table 1: Seal Compatibility for FKM/EPDM Seals

	Fluorelastomer (FKM) Seals	EPDM Seals
Thermal Range of Application	32°F to 375°F (0°C to 190°C)	0°F to 275°F (-18°C to 135°C)
Chemical Resistance	Silicone oil and grease	Silicone oil and grease
	Ozone, aging and weather resistant	Ozone, aging and weather resistant
	Oils and fats	Hot water and steam up to 275°F (135°C)
	Aliphatic, chlorinated and aromatic hydrocarbons	Many organic and inorganic acids
Cleaning agents, soda and potassium alkalis		
Not compatible with	Superheated steam	Mineral oil products (oils, greases and fuels)
	Formic and acetic acids	

Contact WCB Application Engineering for other fluid compatibility.

FKM and EPDM seals comply with FDA regulations.

Seat Options

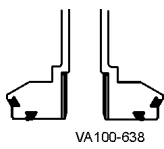
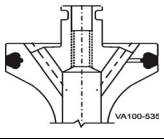
Seat Type		Material / Maximum Temp.
 <p>VA100-638</p>	<p>Tri Ring (TR) Compression Seal: Upper on W71/W72RS Lower on W71/W73</p>	<p>EPDM</p> <p>Operation 280°F (137°C) Sterile 275°F (135°C)</p> <p>or</p> <p>Operation 350°F (176°C) Sterile (Consult Factory)</p>
 <p>VA100-63E</p>	<p>Radial: Lower on W72RS/W72RSP</p>	

For higher temperature applications than those listed, please consult the factory.

Operating conditions such as flow rate and pressure must be considered when operating near the maximum temperature rating. Contact the Factory for FFKM.

Pressure Ratings

Parameter	Valve Size	Pressure Rating
Operating Pressure	1-1/2" - 3"	150 psi (10.3 bar)
	4"	90 psi (6.2 bar)
	6"	Contact Factory
Holding Pressure	All sizes	150 psi (10.3 bar)

Installation



CAUTION: When installing the valve, ensure that no foreign materials (e.g. tools, screws, welding wire, lubricants, cloths, etc.) are enclosed in the system.

Location

The valve must be in a vertical position to ensure that the vent/drain outlet system functions properly.

The vent/drain outlet at the bottom of the Mix Proof valve must not be obstructed. The unrestricted vent/drain outlet must allow leakages and cleaning/rinsing/sterilization fluids to go to atmosphere in order to guarantee mix proof safe separation. If hoses, pipes, or other components are mounted to the vent/drain outlet to prevent splashing of leakage and cleaning/rinsing/sterilization fluids, then they must be designed such that the fluids flow freely to atmosphere.



CAUTION: Isolate products away from the valve prior to performing maintenance.

Locate the valve for easy access for inspection.

Ensure that the valves and pipe systems drain properly. The two-piece body option enables the positions of the connections to be adjusted in relation to each other.

Welding Instructions



CAUTION: Before attempting to butt weld an automatic valve into a line, disassemble the body from the actuator. Dissipate heat away from the valve body to prevent warping.

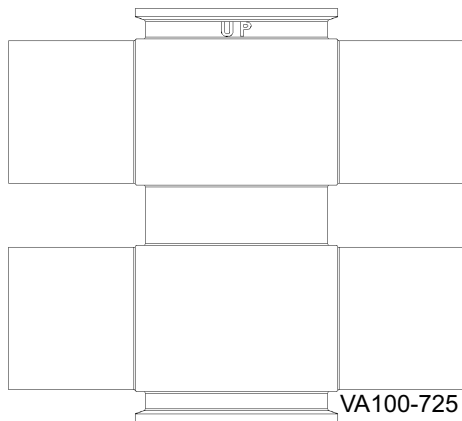

Figure 1 - Valve orientation

Prior to installing, thoroughly inspect each valve. When using buttweld two-piece body valves, clamp connections must be used on either the upper or lower body to allow for servicing of the o-ring seal between the bodies. This does not apply single-piece bodies.

Mix Proof valves with welded connections require the following to be performed before installation:

- Prior to installation, remove the stem actuator assembly and lower bearing carrier.
- Remove all seals from the body.
- Weld the body into position, ensuring that the connection is free of tension and distortion.

NOTE: Orient the valve so that the "UP" inscription (near the adapter-to-body connection) is pointed toward the actuator. See Figure 1.



CAUTION: Welding must be carried out by qualified personnel.

For manifold welding, fixture tables are recommended. Matrix manifold welding requires a controlled deliberate process to maintain the alignment of the parts.

Air Supply

Install the valves using dry, filtered air. Lubrication is not required. If using lubricated air, refer to the solenoid manufacturer's specifications. The air supply must be 75 to 100 psi (5.2 to 6.9 bar).

Flow Direction

The valves should be installed to close against the flow to prevent hammering.

Fittings

When using suitable fittings, Mix Proof valves with detachable connections can be installed in a pipe system per the fitting requirements. The valve must be installed free of tension. After the valve is installed in the pipe system, attach the control air hoses and connect them to the electrical supply.

Contact WCB at 1-800-252-5200 for more information on our wide variety of fittings for all applications.

Pipeline Support

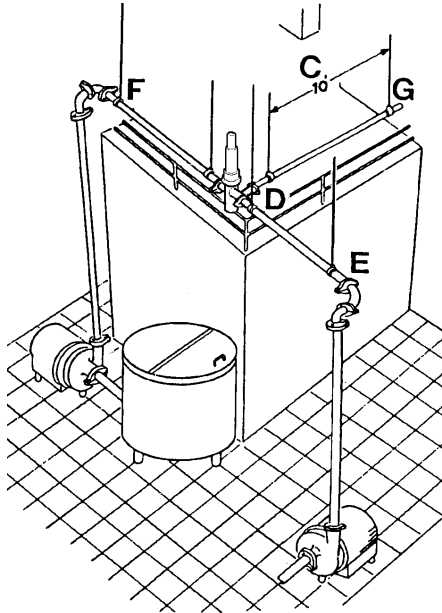

Figure 2 - Pipeline Support

Install adequate supports to prevent strain on the fittings, valves and equipment connections.

1. Install supports at least every 10 feet on straight runs of piping. (Figure 2, item C).
2. Install supports on both sides of the valves as close as possible to the connections. (Figure 2, item D).
3. Install supports at each change of pipeline direction. (Figure 2, item E and F).
4. For pipelines passing through walls, floors or ceilings, provide at least 1 inch (25 mm) of clearance around the pipe to allow for expansion and contraction. (Figure 2, item G).



CAUTION: In higher temperature applications, ensure proper accommodation for thermal expansion in the pipeline design to minimize stresses on the valve bodies. Excessive mechanical and thermal stresses can distort and damage the valve bodies.

Installing Valve Manifolds

Install automatic valve manifolds with a uniform pitch for proper drainage. Elevate one corner of the cluster and pitch 1/16" per foot (1.59 mm per meter) if desired. Arrange the supports for the floor-mounted valve manifolds to provide alignment of the inlet and outlet lines.

Installing the Valve

1. If solenoids are mounted in a control top, connect the air supply lines to "air in." If solenoids are mounted externally from the control top, connect the air lines as explained in "Solenoid Valve Port Connections" on page 16.
2. Using caution, lift the actuator assembly and set the actuator in the body assembly.
3. Lower the valve slowly into the body, making sure the lower stem enters the lower bearing carrier.
4. Tightly clamp the yoke/body flange.
5. Connect the air lines to A, B and C, as shown in Figure 9 on page 15

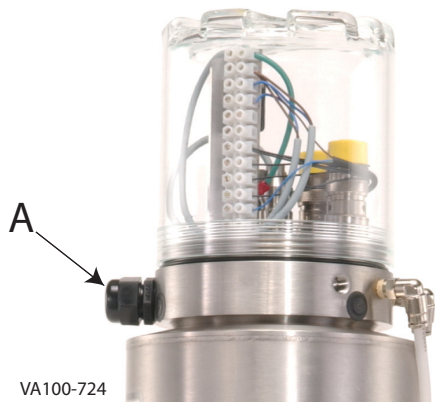

Figure 3 - Control Top Wire Connection Point

6. Connect the electrical control cord to the valve at location A (see Figure 3).

NOTE: Control tops are available with strain relief cord grip for hard wiring or threaded pin connectors for quick disconnect. Mating cables must be ordered separately.

7. Operate the valve through the four conditions (closed, open, upper seat cleaning and lower seat cleaning). See “Solenoid/ Valve Position” on page 16.

Quality of Control Air to Control Module

Do not exceed the following values:

- Suspended solids content:
Particle size: 5 microns max.
Particle Density: 5 mg/m³ max. (= quality class 3)
- Water content: Dewpoint +35°F (+1.6°C)
(= quality class 3). For applications at great elevations or at low ambient temperatures, the dewpoint changes.
- Oil content (if possible, without oil): Up to 25mg/m³ max. oil
(= quality class 5).

External Flush - Liquid Vent Cavity

NOTE: Liquid flush of the vent cavity is typically used in applications with high sugar content product that may crystallize if dried. Cavity flush is recommended after valve transitions to keep the seats and cavity moist.

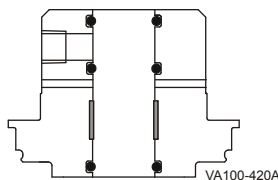

Figure 4 - Upper Stem Flush Adapter

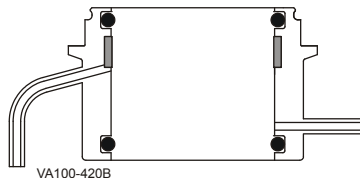

Figure 5 - Lower Stem Flush Adapter

Liquid Vent Cavity Only

Use Upper Stem Flush Adapter

Liquid Vent Cavity and Lower Stem

Use both Upper Stem Flush Adapter and Lower Stem Flush/ Steam Adapter.

Options allow for the liquid flush of the vent cavity and leakage channel alone or with the lower stem flush.

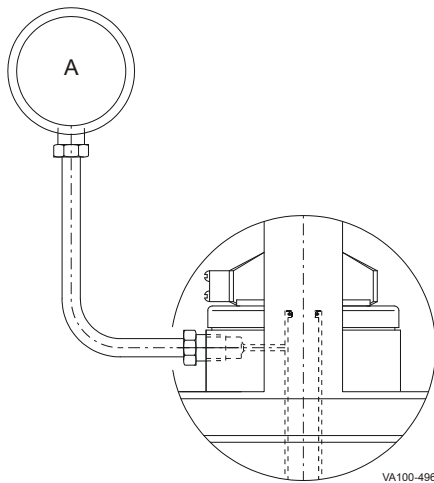

Figure 6 - Connection of Flush Supply

Connect the cavity cleaning supply to a suitable liquid supply to flush the vent/drain (Figure 6) during the operation of the processing system.

The flush supply line can be connected to the pipe system by 1/4" (6 mm) rigid or poly flow tubing. The flush supply is blocked when the valve is open.

Connect the supply line to the adapter connection with poly flow tubing (Figure 6).

WARNING: During CIP cleaning and valve opening (W71/W73), fluid escapes from the drain port. Drain this off to prevent a possible hazard to personnel.

Regulate the flush supply (Figure 6, item A) for pressures of 30 psi minimum, 50 psi maximum.

The maximum solution temperature is 180°F (60°C).

WARNING: Cavity cleaning operation must fall within the fail-safe control system. See "Cleaning" on page 21.

WARNING: Take proper precaution to safeguard the flush water supply, such as installing backflow prevention devices.

External Flush - Steam Vent Cavity

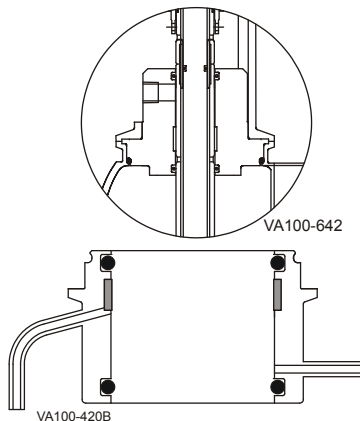

Figure 7 - External Steam Barrier - upper stem

Steam Vent Cavity, Upper and Lower Stem

Use both Upper Stem Steam Flush Adapter and Lower Stem Steam Adapter.

This option allows continuous steaming of the vent cavity (in both open and closed positions), upper and lower stems.

STOP DANGER: Valves equipped with the steam flush option for stem and vent cavity can produce high temperatures and steam hazards that may result in personal injury or death.

To steam flush the upper and/or lower stem as well as the vent cavity, the Mix Proof Valve must be ordered with the Steam Flush for stem and vent cavity. This option (See Figure 8 on page 15) contains the following components:

- External flush connection, 1/4" NPT.
- Modified adapter with removed o-rings to flush the stem.
- Jacket with 1/4" Tube (S.S.) on lower balancer to flush the lower stem (balancer).
- EPDM gaskets for all seals in the wetted area.

Installation

Installation of a steam flush system on a W-Series Mix Proof valve should be done only by a licensed Steam Fitter.

The valve must be installed vertically to drain out any steam/condensate and have a drain funnel placed directly below it. Refer to Figure 8 to see the shut-off valves in the supply lines.

WARNING: The W-Series Mix Proof Valve equipped with the steam flush option for stem and vent cavity is designed **only for low-pressure, product-compatible saturated steam with a maximum pressure of 10 psig (0.65 bar) = 240°F (115°C) temperature.**



DANGER: The steam connection must be shut off and the valve must cool before servicing the valve.

Function

The low pressure steam enters through port B of the upper stem steam flush adapter. Steam purges the outside and inside of the upper stem and the vent cavity. Steam exits out the leakage port F.

For steam flushing the outside of the lower stem (balancer), the low pressure steam enters port D and exits at port E.

Table 2: Callout table for Figure 8

A. Saturated Steam (wet steam) Max 10 psig
B. Steam IN (Upper Stem Adapter)
C. Product
D. Steam IN (Lower Stem Adapter)
E. Steam out of Lower Stem Adapter
F. Steam out from vent cavity (leakage port)

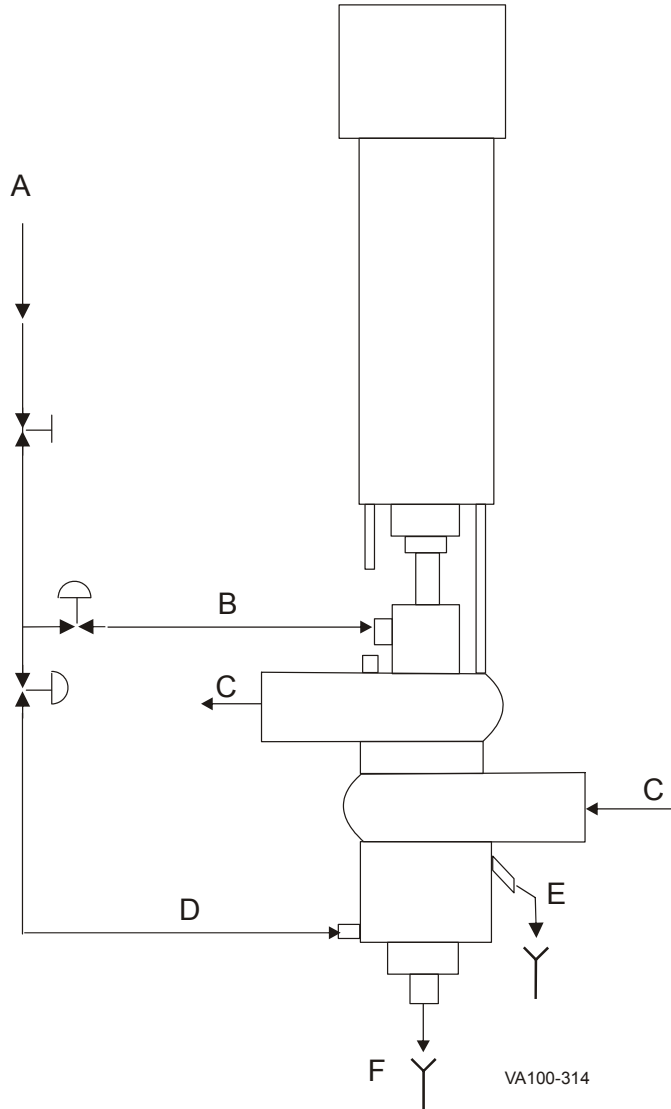

Figure 8 - Steam Flush Option for Stem and Vent Cavity Schematic

Operation

All functions of W-Series mix proof valves are pneumatically controlled using a 75 min. to 100 max. psi (5.2 to 6.9 bar) clean air supply.

The valve contains a large and small spring in the valve actuator. The springs hold the valve seats in the closed position.

Large Spring

- Located in top air chamber of cylinder.
- Holds valve in the closed position.

Small Spring

- Located in the extended hub of the upper piston.
- When the valve is open, the spring acts on the upper seat stem to hold the upper and lower plugs together.

Solenoid Valve Port Connections

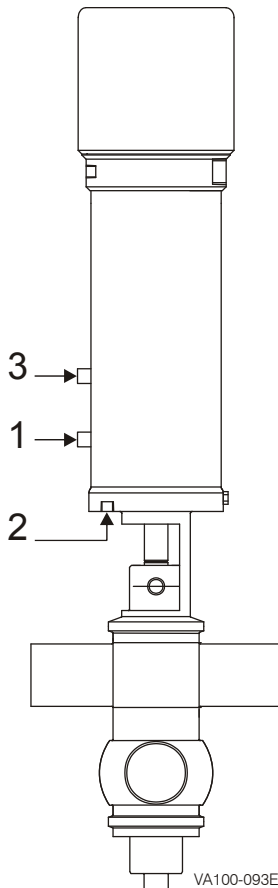

Figure 9 - Solenoid Valve Port Connections

Up to three air supplies controlled by solenoid valves supply air to the valve actuator (Figure 9).

Table 3: Solenoid/Valve Position

Condition	Solenoid 1	Solenoid 2	Solenoid 3
Closed	OFF	OFF	OFF
Open	ON	OFF	OFF
Upper Seat Cleaning *	OFF	ON	OFF
Lower Seat Cleaning *	OFF	OFF	ON

1 = Valve Open Inlet Solenoid

2 = Upper Seat Clean Inlet Solenoid*

3 = Lower Seat Clean Inlet Solenoid*

ON = Solenoid energized (OPEN). LED is lit.

OFF = Solenoid de-energized (CLOSED). LED is off.

Solenoids are normally closed.



Air connections are 1/8" NPT x 1/4" push-to-connect poly tube fittings.

* Seat lifting is an option which requires (2) two additional air supplies. Non-seat lifting valves (NSL) only have one air inlet (1).

For specific air-routing and solenoid porting, please refer to control module publications 95-03083 (2-piece) or 95-03077 (3-Piece (obsoleted)).

Automatic Fail-Safe System

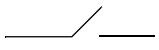
Table 4: Valve Stem Detection Conditions

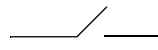
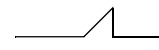
Condition	W71/W73		W72RS/W72RSP	
	Upper Switch (NO)	Lower Switch (NC)	Upper Switch (NO)	Lower Switch (NC)
Switch Symbol				
Valve Closed	0	1	0	1
Valve Open	1	0	1	0
Valve Closed with Upper Seat Clean *	0	1	0	0
Valve Closed with Lower Seat Clean *	0	0	0	1

Notes:

1 = Energized, LED is lit; 0 = De-energized, LED is off

Upper Switch: Sends an input signal when the valve is properly open.

Lower Switch: Sends an input signal when the valve is properly closed.

Additional Switch: A third yoke-mounted proximity switch is available for additional signal feedback.

* W71/W73 Valves: Seat lift during both upper and lower seat clean; indicator stem raises;
 W72RS/W72RSP Valves: Seat lift during upper seat clean; seat push during lower seat clean, indicator stem lowers.

Test Procedures

Positive Fail-Safe Detection Test

Perform a test to verify the fully closed fail-safe position. The valve plug feedback proximity switches should be set for the fully opened and fully closed positions of the valve. See Figure 9 on page 16 for port and corresponding chambers.

Decommission the system, drain the lines and lock out the pumps.

1. With the valve fully closed, confirm that the proximity switches conform to Table 4. Verify the switch status on the PLC control system.
2. Pressurize chamber 1 to open the valve (Figure 9, page 16). Confirm that the proximity switches conform to Table 4. Verify the switch status on the PLC control system.
3. Vent chamber 1 to close the valve.
4. If used, activate the upper seat lift either through the control system or by supplying air to port 2.
5. When the upper seat lifts, confirm that the proximity switches conform to the values in Table 4. If the yoke area does not have a limit switch, visually confirm the upper seat lifting.

6. Vent the air in chamber 2 (Figure 9, page 16) to deactivate the seat lift.
7. If used, pressurize chamber 3 to activate the lower seat push.
8. Confirm that the proximity switches conform to Table 4 on page 17. Verify the switch status on the PLC control system.
9. Vent the air in chamber A to deactivate the seat lift.
10. Disconnect the air from the valve actuator, placing the valve in the fail-safe position. Verify that the proximity switches register that the valve is fully closed.

Corrective Action

If the double seat Mix Proof valve fails to respond as indicated above, immediately check the valve assembly and wiring to locate and correct the cause:

- First, check the proximity switch adjustment.
- Check for the correct assembly and adjustment of the valve.
- For specific information on switch setting, please refer to control module publications 95-03083 (2-piece) or 95-03077 (3-Piece (obsoleted)).

Valve Operating Conditions

See Figure 9 on page 16 for port and corresponding chambers.

Valve Open

The valve is open when Chamber 1 is pressurized and Chambers 3 and 2 are vented. See Figure 10.

Valve Closed

The valve is closed when Chambers 3, 1, and 2 are vented. The large spring closes the valve to the fail safe position. See Figure 11.

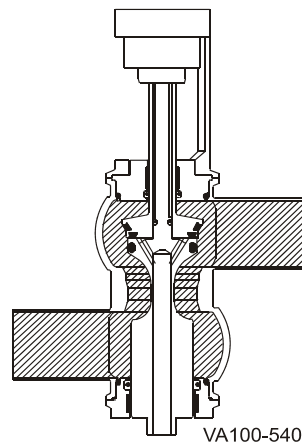

Figure 10 - Valve Open

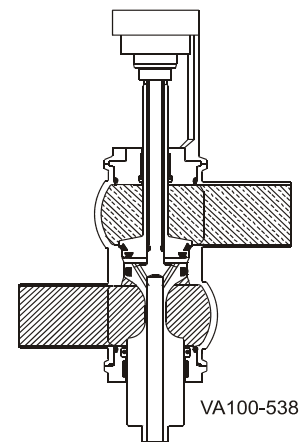

Figure 11 - Valve Closed

Valve Closed, Upper Seat Lifted

For cleaning the upper seat on seat lifting models only. Chamber 2 is pressurized, and Chambers 3 and 1 are vented. See Figure 12.

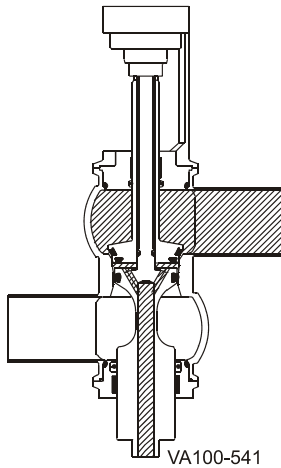

Figure 12 - Valve Closed, Upper Seat Lifted

Valve Closed, Lower Seat Push (for W72RS/W72RSP Series Only)

Chamber 3 is pressurized, and Chambers 1 and 2 are vented. See Figure 13. For W72RS/W72RSP Series valves, the lower seat is pushed down for seat cleaning.

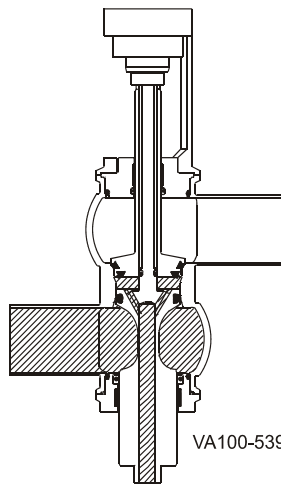

Figure 13 - Lower Seat Lowering for W72RS Series

Valve Closed, Lower Seat Lift (for W71/W73 Series valves only)

The lower seat is lifted for seat cleaning. See Figure 14.

NOTE: On W73 Series valves, the middle-to-lower port divert stem has single-seat protection and cannot perform an independent seat clean operation when the valve is closed or open.

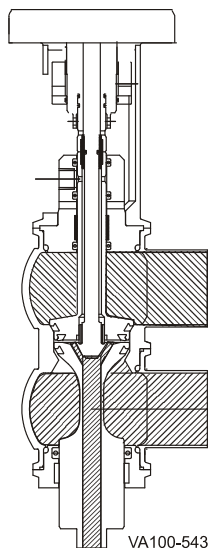

Figure 14 - Lower Seat Lift for W71/W73

Maintenance

Maintenance Intervals

Maintain adequate stock of replacement parts. See the items in bold beginning on page 32 for recommended spare parts.

Maintenance intervals should be determined by the user and specific application, based on the following conditions:

- Daily operation period
- Switching frequency
- Application parameters, such as temperature, pressure, and flow
- Product type
- CIP time and temperature

Use the following recommendation as a rough guide:

- For fluid temperatures ranging from 180°F to 212°F (82°C to 100°C): approx. every 3 to 6 months
- For fluid temperatures of 140°F (60°C): approx. every 12 months

The values listed above are only general guidelines and do not apply, for example, to fluids which crystallize on contact with air. The values listed are subject to the chemical resistance of the seal material.

Inspection



DANGER: Do not put a hand into the yoke or body of a pneumatically-actuated valve.

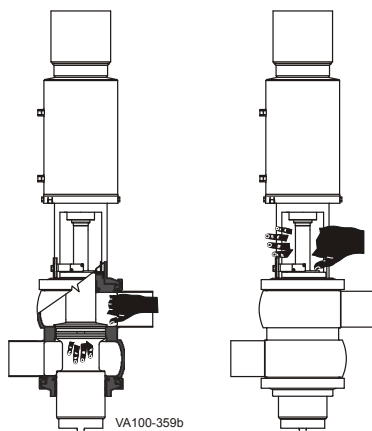

Inspect the following on a regular basis:

- Actuator connections for air leaks
- Valve body and stem o-rings
- Valve seats (If leakage occurs, see “Troubleshooting” on page 86.)
- Pneumatic connections:
 - Air pressure at supply connection
 - Air lines for kinks and leaks
 - Threaded connections for tight fit
 - Clean air filter at regular intervals
- Electrical connections secure on control module:
 - Wire connections tight on terminal strip
 - Electrical connections to control module
 - Threaded strain relief for tight fit.

Lubrication

No lubrication is required other as than noted in the disassembly and assembly procedures. (Use food grade non-petroleum (silicone) grease on seals and o-rings.)

Apply Bostik Never-Seez[®] White Food Grade with PTFE or equivalent to all bolts and threaded stem parts.

Cleaning



CAUTION: Avoid splashing any liquid into the air vent of the actuator during clean up..

NOTE: Actuate each valve or use seat lifting to ensure effective cleaning and sanitizing. Expose all product-contact surfaces to the appropriate cleaning solutions.



CAUTION: During valve opening and CIP cleaning, fluid escapes from the drain port. Drain it off to prevent any possible hazard to personnel.

NOTE: If heavy soils are experienced, seat cleaning is not recommended during the initial rinse.

Cleaning-In-Place (CIP)

CIP methods can be used to clean installed automatic valves without disassembly. Select methods based on the specific requirements of sanitarians and each application. Check with local chemical suppliers for the most effective cleaning agents and procedures intended for the application, in order to properly dissolve the product residue. Ensure that the cleaning agent is compliant with the temperature range.

Mix Proof valves can be fitted with a 1/4 NPT flush connection for rinsing the area between the seats and the vent/drain port. The area can be flushed regularly in the event of long times between CIP cleanings. See “External Flush - Liquid Vent Cavity” on page 13.

Cleaning Procedure

Mix Proof valves are designed to use a cleaning solution supplied by a CIP system. The vent outlet/cavity must be unobstructed to guarantee the leakage of fluid to atmosphere.

Establish cleaning procedures for each installation depending on product characteristics, operating parameters (temperature, velocity, valve cycles), and product velocities.

The following statements are intended as suggestions or guidelines for cleaning procedures and will vary by application:

For seat lifting valves, when the upper or lower body is in CIP, seat movement should occur. Seat cleaning positions are factory-set and marked in the yoke area. Seat cleaning will produce visible leakage from the vent outlet. Brief multiple lifts should occur for each step in the CIP program, excluding the initial rinse.

The lower seat lift cleans the full lower stem product contact area. The cleaning solution exits the valve from the vent cavity.

Maximum Solution Temperature is 160°F (71°C).

Maximum line pressure during seat cleaning is 90 psi (6.2 bar).

Minimum cleaning solution velocity is 5 ft/s (0.3 m/s).

Cleaning time is dependent on the inlet pressure. The recommended cycle time is 3 to 5 seconds per cycle after the valve achieves the seat clean position. This seat clean cycle time of each valve should be visually confirmed during commissioning.

Typical cleaning procedures include pulsing the seat during cleaning until the valve has been demonstrated to be clean. This is usually accomplished in 3 to 5 consecutive pulses per step in the CIP program; however, each installation and product varies, so pulsing should continue until all product/debris is removed.

For the optional external flush of the vent cavity, water flush can be activated during the final rinse.

Every few months of operation, remove and inspect one valve in the system to ensure that complete cleaning is being achieved.

Seat Cleaning Adjustment

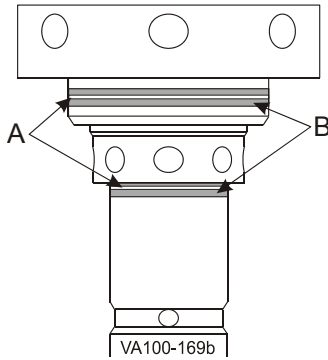

Figure 15 - Adjustment zones with scribe lines

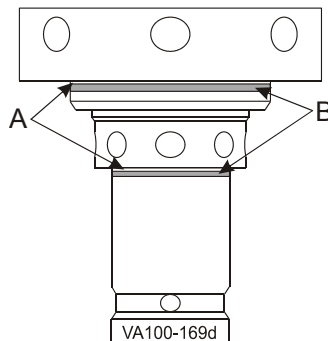
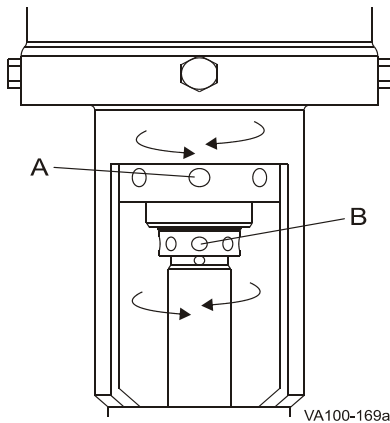

Figure 16 - Bottom edges align with scribe lines



- A. Adjusting nut, upper seat
- B. Adjusting nut, lower seat

Figure 17 - Location of Adjusting Nut

Seat lifting models are factory set. Scribe lines (Figure 15, item A) within the acid-etched adjustment zone (Figure 15, item B) provide a visual indication of the correct factory-set adjustment. Screw the adjusting sleeve and adjusting nut until the bottom edges align with the scribe line (Figure 16, item A).

NOTE: Always adjust the lower seat first.



WARNING: Do not adjust the seat lift collars with pliers, vice-grips or adjustable jaw pliers (channel locks).

If required, adjust the seat movement. With the valve closed, using a 3/16" diameter pin spanner or allen wrench, adjust the movement of the seats to the factory settings or within the adjustment zone (Figure 15 and Figure 16, item B). Once a successful seat movement is established, clearly mark where the bottom edges of the adjusting sleeve and adjusting nut align, to ensure proper resetting after disassembly.

NOTE: The seat lift stroke for the W72RSP is fixed at 0.12" upper and 0.28" lower. Confirm the stroke length after proper assembly; tighten both stems clockwise until they are stopped metal-to-metal.

Lower seat

Operate the lower seat lift cycle. Observe the indicator stem movement at the top of the valve or at the balancer on the bottom of the valve.

To adjust the movement of the lower seat for cleaning, rotate the adjusting sleeve in the yoke (Figure 17, item B):

W71/W73: Rotate right to increase; left to decrease.

W72RS: Rotate left to increase; right to decrease.

Table 5: Proper Movement: Lower Seat

Valve	Setting
W71/W73	0.04" - 0.1" (0.060" Factory Setting)
W72RS	0.18" (1-1/2" and 2" Valves) 0.28" (2-1/2", 3" and 4" Valves)



Upper seat

Operate the upper lift cycle once. Operate three more times to observe the outer stem movement by watching the adjusting nut in the yoke.

To adjust the movement of the upper seat, rotate the adjusting nut (Figure 17, item A) left to increase; right to decrease.

Table 6: Proper Movement: Upper Seat

Valve	Setting
W71/ W73	0.04" - 0.1" (.060" Factory Setting)
W72RS	0.12"

-  This icon indicates a link to a maintenance video available online or in the CD version of this manual.
-  To access the PDF online, go to: http://www.spx.com/en/assets/pdf/95-03087_w70mixproofv_wcb.pdf, or for a CD version, contact your local distributor and ask for CD-1802.

Removing Valve from System

NOTE: If the valve has a control module with a solenoid, the air and electric must remain ON until the valve is properly disassembled.

NOTE: On seat lifting model valves, clearly mark on the other stem and adjusting threads where the bottom edges of the adjusting sleeve and adjusting nut align to ensure proper resetting of seat movements after disassembly.

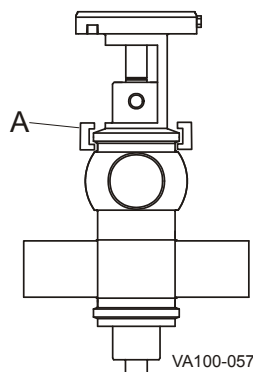





Figure 18 - Location of Adapter Clamp

 **WARNING:** Before removing the actuator/valve stem assembly from the valve body, drain all product lines connected to the body.

1. Clean, rinse, and drain the pipe system elements attached to the valve. Remove or block the fluid and gas lines to prevent material from entering the pipe system elements attached to the valve. If present, disconnect the flush water supply connection. If supplied, seat lifts can be used to check for pressurization.
2. Disconnect the external flush if used.
3. Disconnect the electrical supply and lock out all power.
4. Supply air to the open valve.
5. Remove the clamp between the yoke and the adapter (Figure 18, item A).

 [Maintenance Video 1: Remove valve from body](#)

6. Remove the air pressure to cycle the valve closed, lifting the valve approximately 3/8" (9.5 mm) out of the body. Shut off and disconnect the air supply.
7. Disconnect and lock out electrical power to the valve.
8. Lift the complete valve actuator and stems out of the valve body, being careful not to damage the stems or internals.
9. Move the valve to a work station.
10. Re-install in reverse order. Keep in mind that air must be applied to cycle the valve open and lower the valve insert approximately 3/8", in order to completely reseat the valve in the body. Re-fasten the clamp between the yoke and the adapter, then remove the air pressure to cycle the valve closed.

 [Maintenance Video 2: Re-install valve into body](#)

Disassembly of Valve Stems

Disassembly of the valve stems is required for seat ring replacement. (For "Reassembly of Valve Stems," turn to page 31.)

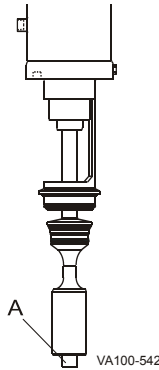

Figure 19 - Valve Stem Removal

NOTE: Seals, seal grooves, and contact surfaces are precision parts and must not be damaged.

1. Lower stem removal: Using an open end wrench, remove the lower stem (Figure 19, item A) from the actuator by turning it counter-clockwise.

[Maintenance Video 3: Remove lower stem](#)

NOTE: (For seat lifting valves) Before disassembly, note the position of the upper and lower seat lifting adjustment nuts. See Figure 17.

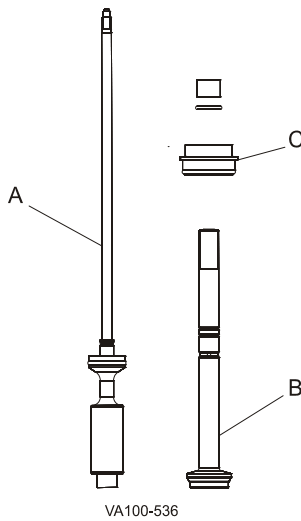

Figure 20 - Stem Removal

2. Upper stem removal: Hold the adjusting sleeve stationary with a spanner wrench, turn the stem (Figure 20, item B) counter-clockwise, and remove it from the actuator. If the adapter (Figure 20, item C) comes out of the yoke, handle it with care.

Table 7: Call-out table for Figure 20

A = Lower Stem
B = Upper Stem
C = Top Adapter (Bonnet)

[Maintenance Video 5: Remove upper stem](#)



WARNING: Do not pressurize the actuator with the stems removed, as internal o-ring damage will result.

Adapter Bearings and O-rings

Inner O-ring and Bearing Replacement

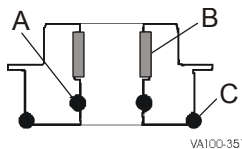

Figure 21 - Standard Top Adapter

1. Remove the valve stem assembly from the actuator and slide the adapter off the outer stem.
2. Remove and replace the o-ring (Figure 21, item A) inside the adapter. For the flush/steam barrier adapters, see Figure 4 on page 13 and Figure 7 on page 14, respectively.

[Maintenance Video 7: Adapter o-rings and bearing removal and replacement](#)

3. Check the split bearing (Figure 21, item B) inside the adapter by feeling the amount protruding from the adapter wall. If the bearing is flush with the wall, replace the bearing.
4. Place a screwdriver behind the bearing and pry it away from the wall of the adapter. A needle-nose pliers can be used to grip the bearing for removal. Be careful not to scratch or damage the metal surfaces.

NOTE: The bearing will be damaged during removal and must be replaced with a new bearing.

5. To install a new bearing, coil the bearing to a size smaller than the inside diameter of the adapter and insert it into the proper location.
6. Using your finger, ensure that the bearing is properly seated. Visually inspect the seating.
7. If necessary, push the actuator stem into the adapter to help properly seat the bearing.

Outer O-ring Replacement

1. Remove the valve stem assembly from the actuator and slide the adapter off the outer stem.
2. Slide or cut the outer o-ring (Figure 21, item C) off the adapter. Do not nick or scratch the o-ring groove.
3. Lubricate the new o-ring with grease and install it.

Tri Ring Seat Replacement

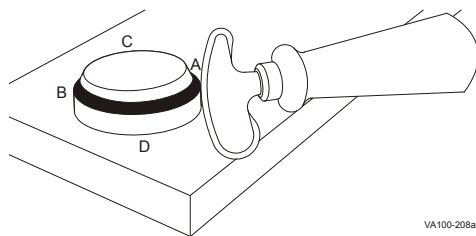

Figure 23 - Pressing Tri Ring Into Plug

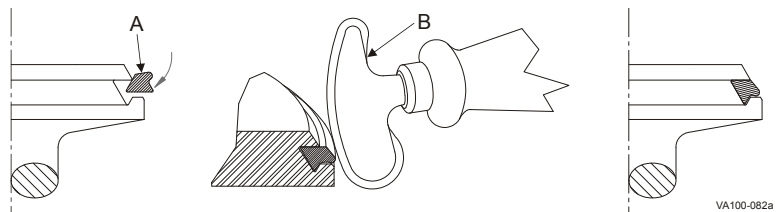

Figure 22 - Installing New Tri Ring Seat

1. Remove the Tri Ring seat by carefully cutting or using an o-ring tool to pull the seat out of the groove. Do not scratch or nick the metal seating surface.

[Maintenance Video 8: Upper stem Tri Ring removal](#)

2. Clean the Tri Ring groove after removing the seat.
3. Lubricate the new Tri Ring (Figure 22, item A) with acceptable cleansing solution or lubricant.
4. Place the stem through a 1-1/8 inch (30 mm) hole bored through a board, secured by a vise.
5. Start the Tri Ring as shown in Figure 22.

[Maintenance Video 9: Upper stem Tri Ring replacement](#)

6. Using the installation tool, part number 102797+ (Figure 22, item B), press the Tri Ring into the plug at locations A, B, C, and D (Figure 23). If the tool is not used, DO NOT use a knife or any other sharp item that will tear or cut the Tri Ring.
7. To finish installation, press small sections of the seal, alternating from side to side (A-B-C-D), avoiding large loops of seal.
8. When properly installed, the Tri Ring seat lip will protrude slightly from the seat edge as shown in Figure 22.

[Maintenance Video 10: Lower stem o-ring and Tri Ring replacement \(W71/W73\)](#)

Radial Seat Ring Replacement (for W72RS Lower Stem)

1. Remove the lower stem radial seal by carefully prying up and cutting the o-ring. Pry up the o-ring and pull it out to remove it. Do not scratch or nick the metal seating surface.

 [Maintenance Video 11: Radial Seal Removal](#)

2. Clean the radial seal groove after removal.
3. Ensure that the vent port in the back of the groove is clean and unblocked.
4. Lubricate the o-ring seal and expand it over the stem groove.
5. Place the assembly tool over the stem, ensuring proper tool orientation. Extrude the o-ring seal into the groove by evenly tightening the cap screws on the installation tool.
6. Remove the tool. The dovetail groove permanently retains the o-ring seal.

 [Maintenance Video 12: Radial Seat Ring Replacement](#)

For a list of installation tools, see "Installation Tools" on page 84.

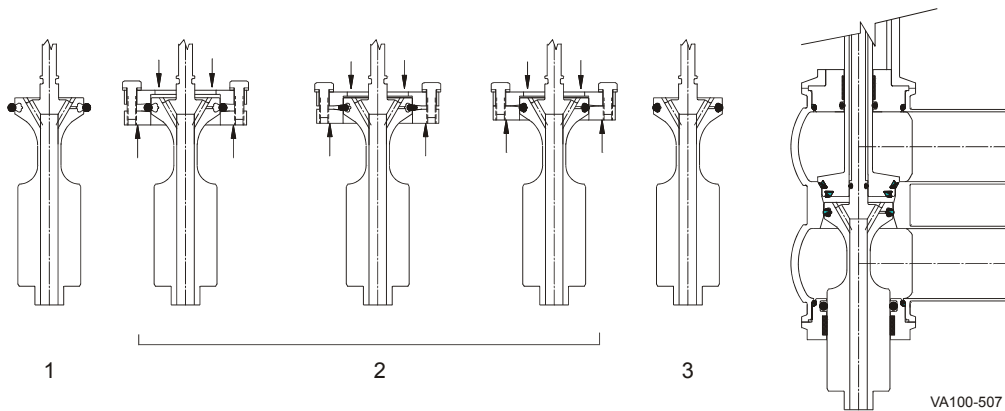

Figure 24 - Radial Seal Installation

Lower Bearing Carrier O-ring and Bearing Replacement

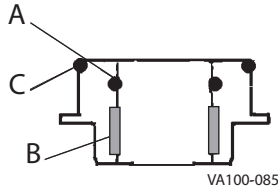



Figure 25 - Standard Lower Bearing Carrier

NOTE: The bearing will be damaged during removal and must be replaced with a new bearing.

1. Remove and replace the o-ring (Figure 25, item A) located inside the lower bearing carrier. For the flush/steam barrier adapter, see Figure 4 on page 13.
 -  [Maintenance Video 13: Lower bearing carrier; removal and replacement of o-ring and bearings](#)
2. Check the split bearing (Figure 25, item B) inside the lower bearing carrier by feeling the amount protruding from the lower bearing carrier wall. If the bearing is flush with the wall, replace the bearing.
3. Place a screwdriver behind the bearing and pry it away from the wall of the lower bearing carrier. A needle-nose pliers can be used to grip the bearing for removal.
4. To install the new bearing, coil the bearing to a size smaller than the inside diameter of the lower bearing carrier and insert it into the proper location.
5. Push the lower stem into the lower bearing carrier to help seat the bearing properly.
6. Using your finger, ensure that the bearing is properly seated. Visually inspect the seating.
7. To remove the outer o-ring (Figure 25, item C), slide or cut the o-ring off the lower bearing carrier. Do not nick or scratch the o-ring groove.
8. Lubricate the new o-ring with grease and install it.
9. Re-install the lower bearing carrier into the body prior to re-installing the entire valve.

Actuator O-ring and Bearing Replacement



CAUTION: The valve stems and actuator must be removed from the valve body before servicing the actuator components.

NOTE: Do not pressurize the actuator with air when the stems are removed. This may tear the o-rings and cause the actuator to leak air when it is re-assembled.

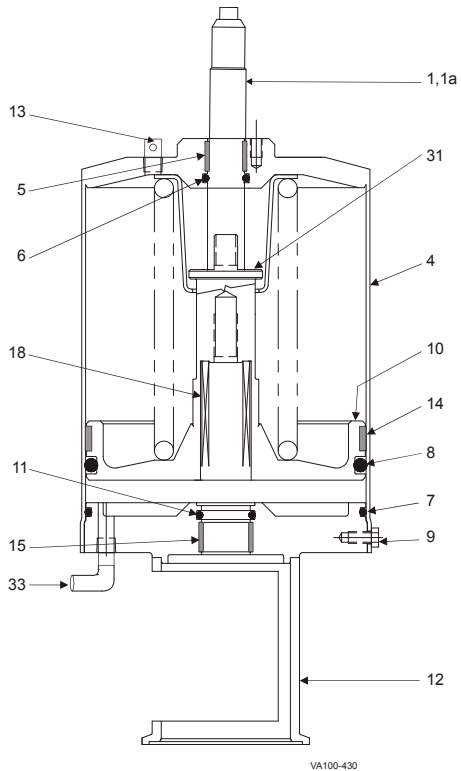

Figure 26 - W71/W73 Actuator Assembly (Non-Seat Lift Valve)

NOTE: The bearing will be damaged during removal and must be replaced with a new bearing.

NOTE: Installation of the piston and spring assembly on 4" actuators requires a special sleeve to contain the bearing on the piston while installing the assembly. See Figure 28 and Figure 29 on page 30.

Removal of O-rings and Bearings, Non-Seat Lifting Actuators

NOTE: If present, the control module must be removed to replace the o-rings and bearings in the top of the cylinder assembly. Please refer to control module publications 95-03083 (2-piece) or 95-03077 (3-Piece (obsoleted)).

Non Seat Lifting Actuators

1. For non-seat lifting valves, remove the cap screws (Figure 26, item 9) and remove the yoke (item 12) from the cylinder assembly. Set the yoke aside.

[Maintenance Video 14: Actuator disassembly; lower cartridge removal](#)

2. Pull the piston and spring assembly (Figure 26, item 10) from the cylinder assembly.

3. Inspect the four o-rings (Figure 26, items 6, 7, 8, and 11). Replace them if they are worn or damaged.

[Maintenance Video 17: Main piston o-ring removal](#)

[Maintenance Video 18: Main piston o-ring replacement with bearing](#)

4. Inspect the three bearings (Figure 26, items 5, 14, and 15). If the bearing does not extend slightly above the edge of the metal surface, replace the bearing.

5. The bearing is split to allow its removal from the groove. Place a screwdriver behind the bearing and pry it away from the wall of the yoke. A needle-nose pliers can be used to grip the bearing for removal.

6. For non-seat lifting valves, assemble the stack components as shown in Figure 26. Install the yoke and cap screws.

[Maintenance Video 22: Using insertion sleeve for W71/W73 Actuators](#)

NOTE: For larger drawings and complete partlists, see "W71/W73 Non-Seat Lift Actuator" on page 76 and "W72RS Non Seat Lift Actuator" on page 80.

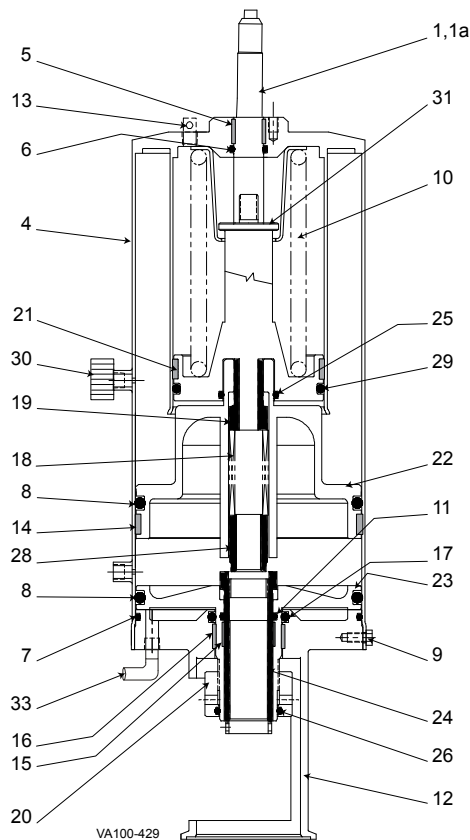

**Figure 27 - W71/W73 Actuator Assembly
(Seat Lift Valve)**

 [Maintenance Video 18: Main piston o-ring replacement with bearing](#)

 [Maintenance Video 19: Can top bearing and o-ring; removal and replacement](#)

 [Maintenance Video 20: Main piston bearing](#)

 [Maintenance Video 21: Lower seat lift piston reassembly](#)

 [Maintenance Video 23: Reassembly of actuator: spacers and inner spring](#)

 [Maintenance Video 24: Reassembly of lower cartridge o-rings and bearings](#)

 [Maintenance Video 25: Re-installation of lower cartridge](#)

Removal of O-rings and Bearings, Seat Lifting Actuators

NOTE: For larger drawings and complete partlists, see “W71/W73 Seat Lift Actuator” on page 78 and “W72RS/W72RSP Seat Lift Actuator” on page 82.

1. For seat lifting valves, remove the cap screws (Figure 27, item 9) and remove the lower cartridge (yoke, item 12; adjusting nut, item 20; adjusting sleeve, item 24; and upper seat piston, item 23).

 [Maintenance Video 14: Actuator disassembly; lower cartridge removal](#)

2. To disassemble the cartridge, remove the adjusting nut (item 20) and separate the parts.

 [Maintenance Video 15: Adjusting Nut removal](#)

3. Remove the small spring (Figure 27, item 18). On W71/W73 valves, also remove the bushing (Figure 26, item 28).
4. Pull out the upper cartridge (main piston, item 22; lower seat spring and piston, item 10), by carefully threading in the lower stem to pull it. Do not bend the lower stem.

Alternate method: Flip the canister right-side up and gently tap it on the table (or push down the indicator stem) until the air vacuum releases and the upper cartridge slides out the open end.

 [Maintenance Video 17: Main piston o-ring removal](#)

5. Inspect the nine o-rings (Figure 27, items 6, 7, 8, and 11) and replace them if they are worn or damaged.
6. Inspect the five bearings on W71/W73 (Figure 27, items 5, 14, 15, 16, and 21) or four bearings on W72RS actuators (items 5, 14, 15, and 16). If the bearing does not extend slightly above the edge of the metal surface, replace it.
7. The bearing is split to allow its removal from the groove. Place a screwdriver behind the bearing and pry it away from the wall of the yoke. A needle-nose pliers can be used to grip the bearing for removal.

NOTE: The bearing will be damaged during removal and must be replaced with a new bearing.

8. For seat lifting valves, assemble the stack components as shown. Make sure that the upper cartridge components are fully inserted. Install the yoke and adjustment nut.

NOTE: Installation of the piston and spring assembly on 4" actuators requires a special sleeve to contain the bearing on the piston while installing the assembly. See Figure 29 and Figure 28 on page 30.

 [Maintenance Video 22: Using insertion sleeve for W71/W73 Actuators](#)

Installation of Piston and Spring Assembly Using Insertion Sleeve for W71/W73 4" Diameter Actuators

The installation of the piston and spring assembly in the cylinder requires a special sleeve to contain the bearing on the piston during installation. See Figure 29 and Figure 28. See Figure 32 on page 84 for part number and dimensional details.

- Push the insertion sleeve up into the cylinder assembly.
- When the sleeve is stopped, push the piston and spring assembly up into the cylinder assembly.

 [Maintenance Video 22: Using insertion sleeve for W71/W73 Actuators](#)

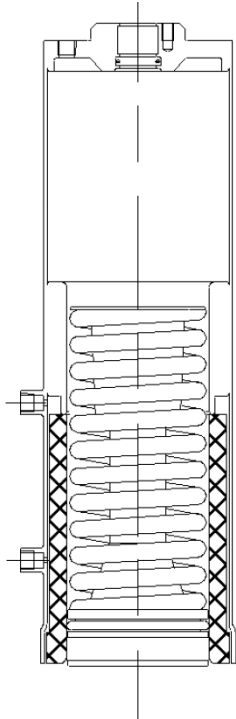

VA100-640

Figure 28 - Installation of Piston and Spring Assembly Using Insertion Sleeve

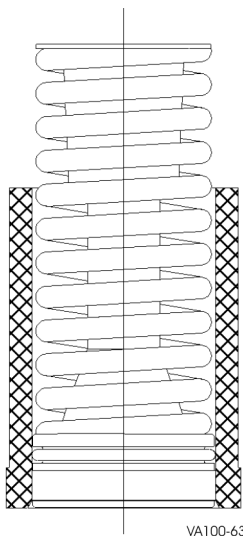

VA100-639

Figure 29 - Piston and Spring Assembly Installed in Insertion Sleeve

Reassembly of Valve Stems

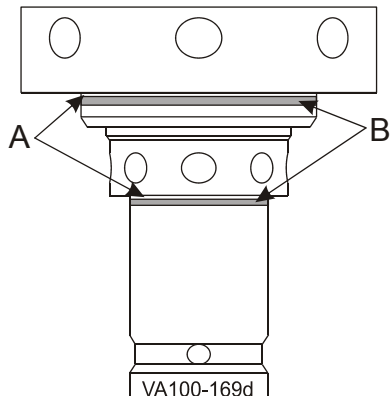

Figure 30 - Assembly

NOTE: Perform maintenance on stems and adapter bearings and o-rings while the stems are removed from the actuator and before reassembly.

Upper Stem Assembly

1. Apply Bostik® Never-Seez White Food Grade with PTFE or equivalent to the threads of the upper stem.
2. Screw the upper stem clockwise into the actuator. Hold the adjusting sleeve stationary with a spanner or allen wrench.
3. Screw the upper stem in until the scribe line (Figure 30, item A) within the etch mark adjustment zone (item B) aligns with the bottom of the adjustment sleeve. This is the factory-set lower seat clean position. See “Seat Cleaning Adjustment” on page 22 for instructions on modifying the seat clean movement.

 [Maintenance Video 6: Upper stem reassembly into valve](#)



WARNING: Do not screw the upper stem all the way into the actuator, as internal o-ring damage may result.

Lower Stem Assembly

1. Apply Bostik® Never-Seez White Food Grade with PTFE or equivalent to the threads of lower stem.
2. If the valve has external flush, slide the spray bushing onto the inner stem of the lower stem.
3. Screw the lower stem clockwise into the actuator until metal-to-metal contact stops.
4. Using an open-end wrench and rubber hammer, rap the lower stem to lock the threads into place within the actuator.

 [Maintenance Video 4: Lower stem reassembly into valve](#)

W71 Mix Proof Non-Seat Lift Valve

Item #	Part Description		1-1/2"	2"	2-1/2"	3"	4"	6"
1	Control Top		Contact Factory					
3	Actuator		***					
* 4	O-ring, Inner Stem	Nitrile	N70010	N70010	N70111	N70111	N70111	N70111
* 5	Bearing, Upper Adapter		102757+	102757+	106047+	106047+	106047+	101995+
* 6	O-ring, Body (see note 2)	EPDM	E70223	E70228	E70232	E70236	E70244	E70258
		FKM	V70223	V70228	V70232	V70236	V70244	V70258
8	Stem, Upper (see note 1)							
* 10a	Seat Ring -Tri Ring, Upper	EPDM	106031+	102736+	107048+	102488+	102491+	102738+
		FKM	107990+	107980+	107982+	107974+	107977+	108020+
* 11	Seat Ring -Tri Ring, Vent	EPDM	106041+	107693+	107696+	107697+	102490+	102737+
		FKM	107992+	107984+	107987+	107988+	107976+	108019+
* 12a	Seat Ring -Tri Ring, Lower	EPDM	106036+	107693+	102487+	102489+	102492+	102739+
		FKM	107991+	107984+	107973+	107975+	107978+	108021+
* 14a	Quad Ring, Lower	EPDM	122689+	35413+	34429+	117561+	116952+	122350+
		FKM	122690+	35414+	35415+	117562+	116953+	122351+
* 14b	Wiping Stem Seal, Lower	EPDM	116186+	116188+	116190+	116195+	116199+	POA
		FKM	116187+	116189+	116191+	116196+	116200+	POA
* 15	Bearing, Lower Seal Retainer		101947+	102000+	106049+	106048+	102003+	102004+
16	Stem, Lower Assembly (see note 1)							
17a	Seal Retainer, Quad Ring		106066+	106067+	106068+	106069+	106070+	125047+
17b	Seal Retainer, Wiping Stem Seal		117444+	117445+	117446+	117447+	117448+	POA
18	Clamp (see note 2)		119-30	119-33	119-34	119-51	119-87	119-123
20a/c	Adapter, O-ring or Quad Ring		111043+	111017+	111196+	111026+	111029+	123970+
20b	Adapter, Wiping Stem Seal		117840+	117841+	117842+	117843+	117878+	POA
* 21a	O-ring, Upper Stem	EPDM	E70210	E70210	E70214	E70214	E70214	N/A
		FKM	V70210	V70210	V70214	V70214	V70214	N/A
* 21c	Quad Ring, Upper Stem	EPDM	121300+	121300+	124163+	124163+	124163+	114221+
		FKM	124088+	124088+	121299+	121299+	121299+	114223+
* 21b	Wiping Stem Seal, Upper	EPDM	116183+	116183+	116184+	116184+	116184+	POA
		FKM	115626+	115626+	116185+	116185+	116185+	POA
* 25	O-ring, Non-Flush	EPDM	E70115	E70115	E70121	E70121	E70121	E70121
		FKM	V70115	V70115	V70121	V70121	V70121	V70121

Notes:

PL5027-CH47a

* Recommended Spare Parts

*** See actuator parts lists

1. For items 8 and 16, see W71 Mix Proof Non-Seat Lift Valve Stems Chart.

2. For one-piece body, qty. 2 are required for item 6 and item 18; for a clamped body, qty. 3 are required.

4. Unless otherwise noted, quantity required is 1.

6. POA = Part # on availability; N/A = not available with this design.

W71 Mix Proof Non-Seat Lift Valve with External Flush

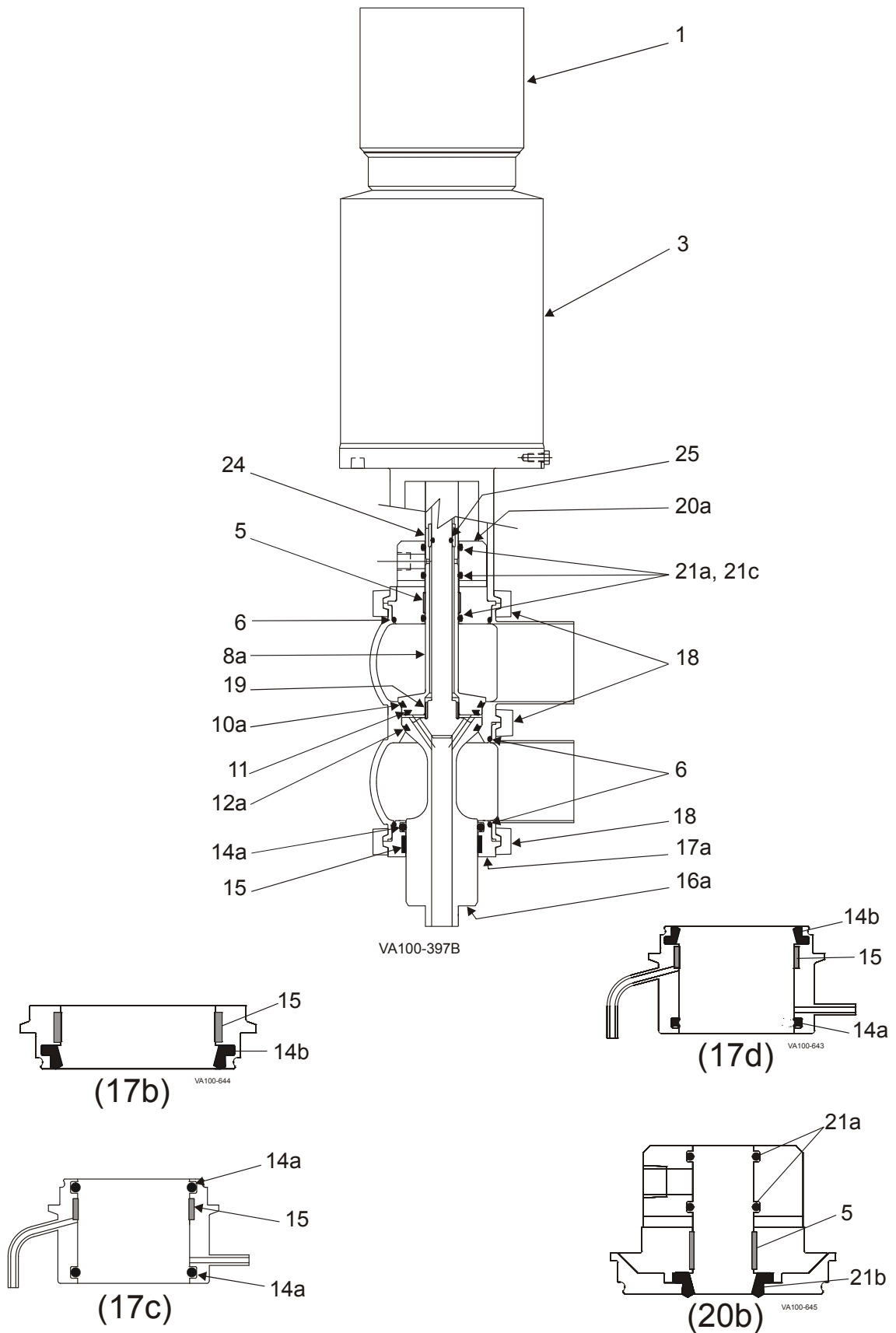

W71 Mix Proof Non-Seat Lift Valve with External Flush

Item #	Part Description	1-1/2"	2"	2-1/2"	3"	4"	6"
1	Control Top	Contact Factory					
3	Actuator	***					
* 4	O-ring, Inner Stem (not shown)	Nitrile	N70010	N70010	N70111	N70111	N70111
* 5	Bearing, Upper Adapter		102757+	102757+	106047+	106047+	101995+
* 6	O-ring, Body (see note 2)	EPDM	E70223	E70228	E70232	E70236	E70244
		FKM	V70223	V70228	V70232	V70236	V70244
8	Stem, Upper Assembly - See note 1, below						
* 10a	Seat Ring -Tri Ring, Upper	EPDM	106031+	102736+	107048+	102488+	102491+
		FKM	107990+	107980+	107982+	107974+	107977+
* 11	Seat Ring -Tri Ring, Vent	EPDM	106041+	107693+	107696+	107697+	102490+
		FKM	107992+	107984+	107987+	107988+	107976+
* 12a	Seat Ring -Tri Ring, Lower	EPDM	106036+	107693+	102487+	102489+	102492+
		FKM	107991+	107984+	107973+	107975+	107978+
* 14a	Quad Ring, Lower	EPDM	122689+	35413+	34429+	117561+	116952+
		FKM	122690+	35414+	35415+	117562+	116953+
* 14b	Wiping Stem Seal, Lower	EPDM	116186+	116188+	116190+	116195+	116199+
		FKM	116187+	116189+	116191+	116196+	116200+
* 15	Bearing, Lower Seal Retainer		101947+	102000+	106049+	106048+	102003+
16	Stem, Lower Assembly - See note 1, below						
17a	Seal Retainer, Quad Ring		106066+	106067+	106068+	106069+	106070+
17b	Seal Retainer, Wiping Stem Seal		117444+	117445+	117446+	117447+	117448+
17c	Seal Retainer, Lower Flush, Quad Ring		114918+	117728+	114920+	117736+	118364+
17d	Seal Retainer, Lower Flush, Wiping Stem Seal		119050+	119035+	118226+	117559+	118253+
18	Clamp		119-30	119-33	119-34	119-51	119-87
19	Spray Bushing		106030+	106030+	107950+	107950+	107950+
20a/c	Adapter, O-ring or Quad Ring		106020+	106021+	106022+	106023+	106024+
20b	Adapter, Wiping Stem Seal		119467+	119468+	119569+	119470+	119471+
* 21a	O-ring, Upper Stem (qty 3 req'd)	EPDM	E70210	E70210	E70214	E70214	E70214
		FKM	V70210	V70210	V70214	V70214	V70214
* 21c	Quad Ring, Upper Stem (qty 3 req'd)	EPDM	121300+	121300+	124163+	124163+	124163+
		FKM	124088+	124088+	121299+	121299+	121299+
* 21b	Wiping Stem Seal, Upper (qty 3 req'd)	EPDM	116183+	116183+	116184+	116184+	116184+
		FKM	115626+	115626+	116185+	116185+	116185+
24	Stem, Actuator, NSL Flush - See note 1, below						
* 25	O-ring, Flush	EPDM	E70010	E70010	E70111	E70111	E70111
		FKM	V70010	V70010	V70111	V70111	V70111

Notes: * Recommended Spare Parts

PL5027-CH48a

*** See actuator parts lists

1. For items 8, 16, and 24, see W71 Mix Proof Non-Seat Lift with External Flush Valve Stems Chart.
2. For one-piece body, qty. 2 are required for item 6 and item 18; for a clamped body, qty. 3 are required.
4. Unless otherwise noted, quantity required is 1.
6. POA = Part # on availability; N/A = not available with this design.

W71 Mix Proof Non-Seat Lift Valve with Steam Adapter

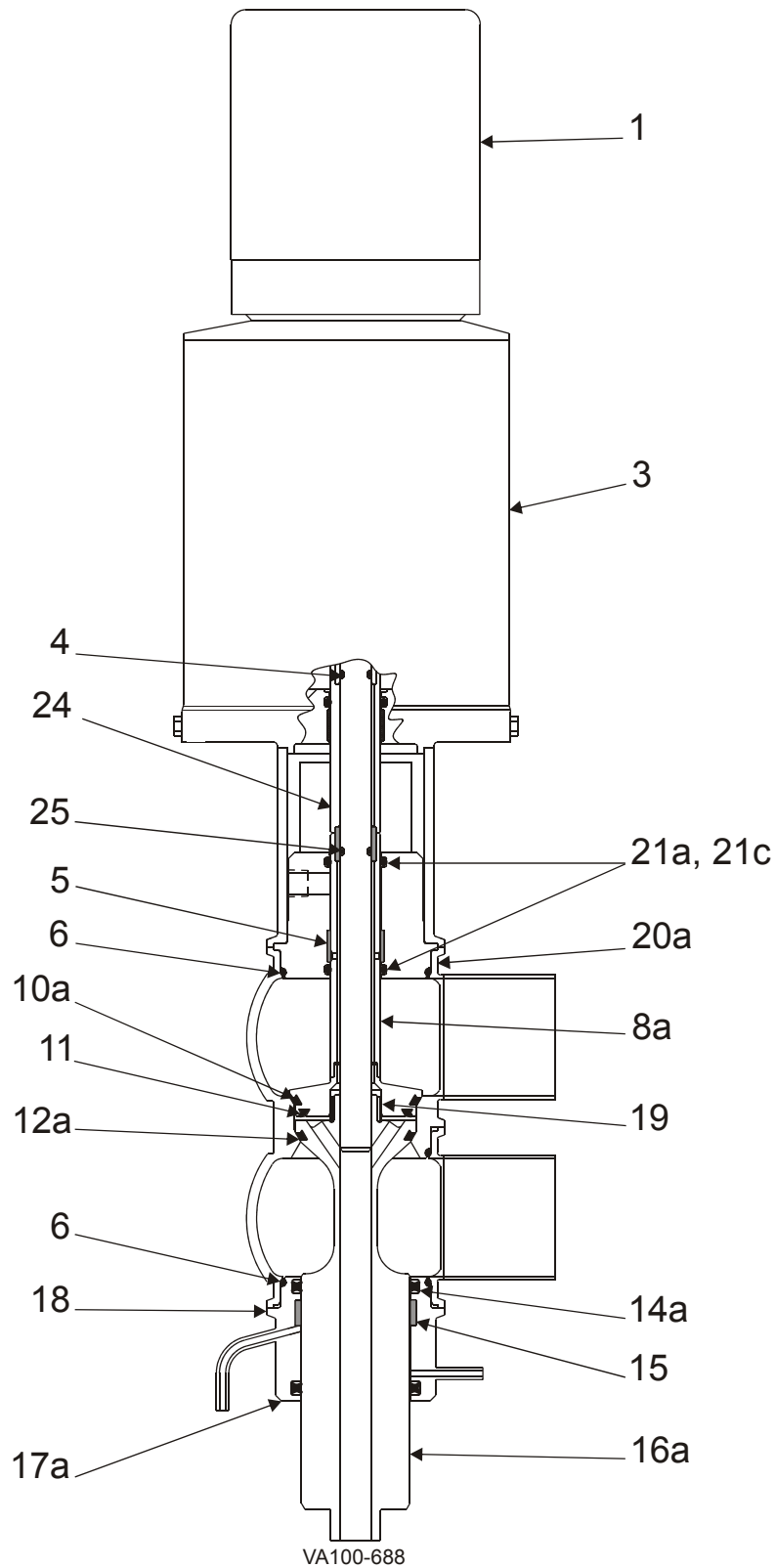

W71 Mix Proof Non-Seat Lift Valve with Steam Adapter

Item #	Part Description	1-1/2"	2"	2-1/2"	3"	4"	6"
1	Control Top	Contact Factory					
3	Actuator	***					
* 4	O-ring, Inner Stem Nitrile	N70010	N70010	N70111	N70111	N70111	N70111
* 5	Bearing, Upper Adapter	102757+	102757+	106047+	106047+	106047+	101995+
* 6	O-ring, Body (see note 2) EPDM	E70223	E70228	E70232	E70236	E70244	E70258
	FKM	V70223	V70228	V70232	V70236	V70244	V70258
8	Stem, Upper Assembly - See note 1, below						
* 10a	Seat Ring -Tri Ring, Upper EPDM	106031+	102736+	107048+	102488+	102491+	102738+
	FKM	107990+	107980+	107982+	107974+	107977+	108020+
* 11	Seat Ring -Tri Ring, Vent EPDM	106041+	107693+	107696+	107697+	102490+	102737+
	FKM	107992+	107984+	107987+	107988+	107976+	108019+
* 12a	Seat Ring -Tri Ring, Lower EPDM	106036+	107693+	102487+	102489+	102492+	102739+
	FKM	107991+	107984+	107973+	107975+	107978+	108021+
* 14a	Quad Ring, Lower (qty 2 req) EPDM	122689+	35413+	34429+	117561+	116952+	122350+
	FKM	122690+	35414+	35415+	117562+	116953+	122351+
* 15	Bearing, Lower Seal Retainer	101947+	102000+	106049+	106048+	102003+	102004+
16	Stem, Lower Assembly - See note 1, below						
17a	Seal Retainer, Lower Flush, Quad Ring	POA	117728+	122609+	117736+	118364+	POA
18	Clamp	119-30	119-33	119-34	119-51	119-87	119-123
19	Spray Bushing	106030+	106030+	107950+	107950+	107950+	107950+
20a	Adapter, O-ring or Quad Ring	POA	117741+	114925+	117742+	114927+	POA
* 21a	O-ring, Upper Stem (qty 2 req) EPDM	E70210	E70210	E70214	E70214	E70214	N/A
	FKM	V70210	V70210	V70214	V70214	V70214	POA
* 21c	Quad Ring, Upper Stem (qty 2 req) EPDM	121300+	121300+	124163+	124163+	124163+	114221+
	FKM	124088+	124088+	121299+	121299+	121299+	114223+
24	Stem, Actuator, NSL Flush - See note 1, below						
* 25	O-ring, Flush (not shown) EPDM	E70010	E70010	E70111	E70111	E70111	E70111
	FKM	V70010	V70010	V70111	V70111	V70111	V70111

Notes: * Recommended Spare Parts

PL5027-CH86a

*** See actuator parts lists

1. For items 8, 16, and 24, see W71 Mix Proof Non-Seat Lift with Steam Adapter Valve Stems Chart.
2. For one-piece body, qty. 2 are required for item 6 and item 18; for a clamped body, qty. 3 are required.
4. Unless otherwise noted, quantity required is 1.
5. **EPDM recommended on all steam-contact seals.**
6. POA = Part # on availability; N/A = not available with this design.

W71 Mix Proof Seat Lift Valve

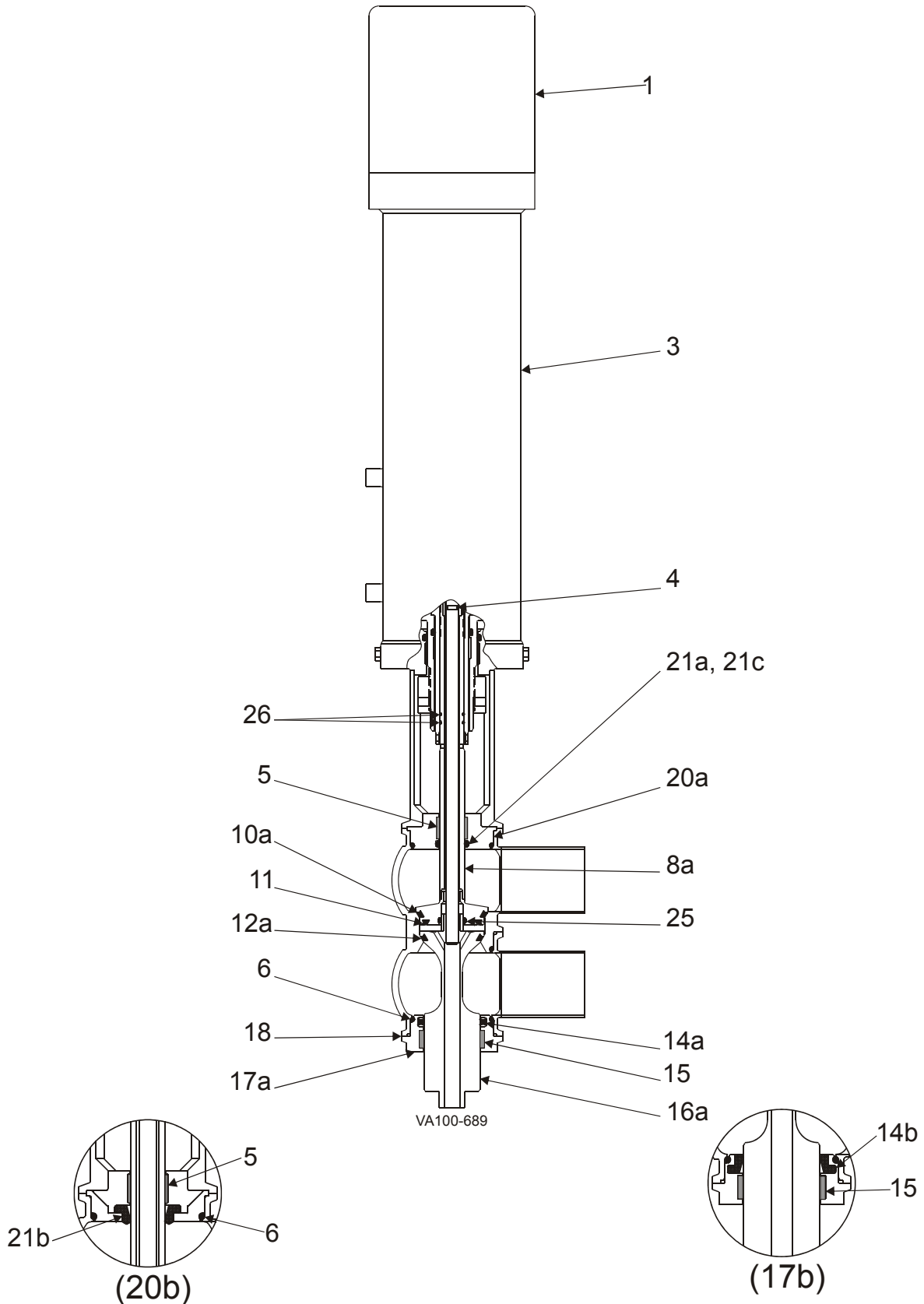

W71 Mix Proof Seat Lift Valve

Item #	Part Description		1-1/2"	2"	2-1/2"	3"	4"	6"
1	Control Top		Contact Factory					
3	Actuator		***					
* 4	O-ring, Inner Stem	Nitrile	N70010	N70010	N70111	N70111	N70111	N70111
* 5	Bearing, Upper Adapter		102757+	102757+	106047+	106047+	106047+	101995+
* 6	O-ring, Body (see note 2)	EPDM	E70223	E70228	E70232	E70236	E70244	E70258
		FKM	V70223	V70228	V70232	V70236	V70244	V70258
8	Stem, Upper - See note 1, below							
* 10a	Seat Ring -Tri Ring, Upper	EPDM	106031+	102736+	107048+	102488+	102491+	102738+
		FKM	107990+	107980+	107982+	107974+	107977+	108020+
* 11	Seat Ring -Tri Ring, Vent	EPDM	106041+	107693+	107696+	107697+	102490+	102737+
		FKM	107992+	107984+	107987+	107988+	107976+	108019+
* 12a	Seat Ring -Tri Ring, Lower	EPDM	106036+	107693+	102487+	102489+	102492+	102739+
		FKM	107991+	107984+	107973+	107975+	107978+	108021+
* 14a	Quad Ring, Lower	EPDM	122689+	35413+	34429+	117561+	116952+	122350+
		FKM	122690+	35414+	35415+	117562+	116953+	122351+
* 14b	Wiping Stem Seal, Lower	EPDM	116186+	116188+	116190+	116195+	116199+	POA
		FKM	116187+	116189+	116191+	116196+	116200+	POA
* 15	Bearing, Lower Seal Retainer		101947+	102000+	106049+	106048+	102003+	102004+
16	Stem, Lower Assembly - See note 1, below							
17a	Seal Retainer, Quad Ring		106066+	106067+	106068+	106069+	106070+	125047+
17b	Seal Retainer, Wiping Stem Seal		117444+	117445+	117446+	117447+	117448+	POA
18	Clamp		119-30	119-33	119-34	119-51	119-87	119-123
20a	Adapter, O-ring or Quad Ring		111043+	111017+	111196+	111026+	111029+	123970+
20b	Adapter, Wiping Stem Seal		117840+	117841+	117842+	117843+	117878+	POA
* 21a	O-ring, Upper Stem	EPDM	E70210	E70210	E70214	E70214	E70214	N/A
		FKM	V70210	V70210	V70214	V70214	V70214	N/A
* 21c	Quad Ring, Upper Stem	EPDM	121300+	121300+	124163+	124163+	124163+	114221+
		FKM	124088+	124088+	121299+	121299+	121299+	114223+
* 21b	Wiping Stem Seal, Upper	EPDM	116183+	116183+	116184+	116184+	116184+	POA
		FKM	115626+	115626+	116185+	116185+	116185+	POA
* 25	O-ring, Non-Flush	EPDM	E70115	E70115	E70121	E70121	E70121	E70121
		FKM	V70115	V70115	V70121	V70121	V70121	V70121
* 26	O-ring, outer stem (qty 2 req)	Nitrile	N90016	N90016	N90020	N90020	N90020	N90020

Notes:

PL5027-CH49a

- * Recommended Spare Parts
- *** See actuator parts lists
- 1. For items 8 and 16, see W71 Mix Proof Seat Lift Valve Stems Chart.
- 2. For one-piece body, qty. 2 are required for item 6 and item 18; for a clamped body, qty. 3 are required.
- 4. Unless otherwise noted, quantity required is 1.
- 6. POA = Part # on availability; N/A = not available with this design.

W71 Mix Proof Seat Lift Valve with External Flush

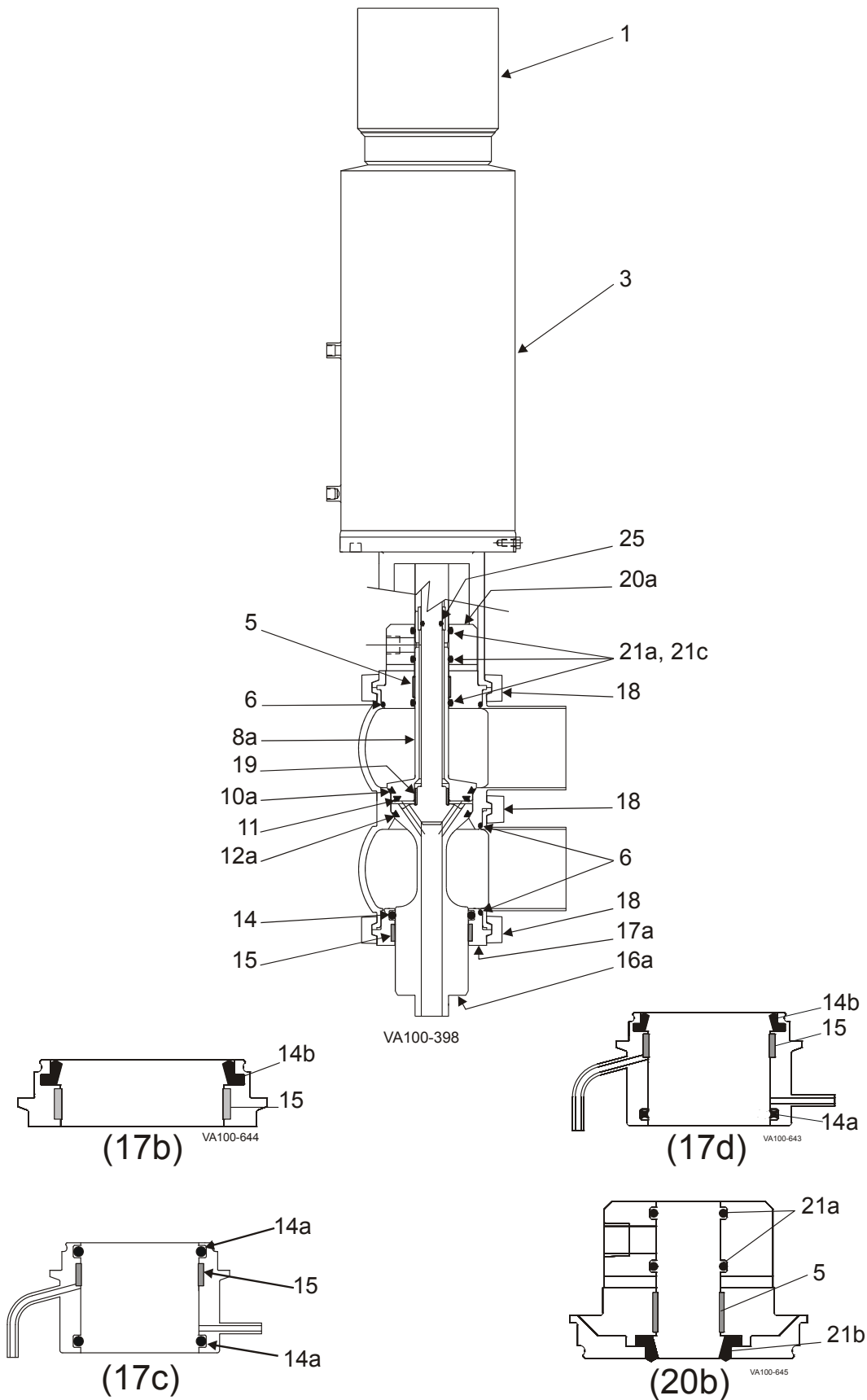

W71 Mix Proof Seat Lift Valve with External Flush

Item #	Part Description		1-1/2"	2"	2-1/2"	3"	4"	6"
1	Control Top		Contact Factory					
3	Actuator		***					
* 4	O-ring, inner stem (not shown)	Nitrile	N70010	N70010	N70111	N70111	N70111	N70111
* 5	Bearing, Upper Adapter		102757+	102757+	106047+	106047+	106047+	101995+
* 6	O-ring, Body (see note 2)	EPDM	E70223	E70228	E70232	E70236	E70244	E70258
		FKM	V70223	V70228	V70232	V70236	V70244	V70258
8	Stem, Upper Assembly - See note 1, below							
* 10a	Seat Ring -Tri Ring, Upper	EPDM	106031+	102736+	107048+	102488+	102491+	102738+
		FKM	107990+	107980+	107982+	107974+	107977+	108020+
* 11	Seat Ring -Tri Ring, Vent	EPDM	106041+	107693+	107696+	107697+	102490+	102737+
		FKM	107992+	107984+	107987+	107988+	107976+	108019+
* 12a	Seat Ring -Tri Ring, Lower	EPDM	106036+	107693+	102487+	102489+	102492+	102739+
		FKM	107991+	107984+	107973+	107975+	107978+	108021+
* 14a	Quad Ring, Lower	EPDM	122690+	35413+	34429+	117561+	116952+	122350+
		FKM	122689+	35414+	35415+	117562+	116953+	122351+
* 14b	Wiping Stem Seal, Lower	EPDM	116186+	116188+	116198+	116195+	116199+	POA
		FKM	116187+	116189+	116191+	116196+	116200+	POA
* 15	Bearing, Lower Seal Retainer		101947+	102000+	106049+	106048+	102003+	102004+
16	Stem, Lower Assembly - See note 1, below							
17a	Seal Retainer, Quad Ring		106066+	106067+	106068+	106069+	106070+	125047+
17b	Seal Retainer, Wiping Stem Seal		117444+	117445+	117446+	117447+	117448+	POA
17c	Seal Retainer, Lower Flush, Quad Ring		121374+	117728+	122609+	117736+	118364+	POA
17d	Seal Retainer, Lower Flush, Wiping Stem Seal		119050+	119035+	118226+	117559+	118253+	POA
18	Clamp		119-30	119-33	119-34	119-51	119-87	119-123
19	Spray Bushing		106030+	106030+	107950+	107950+	107950+	107950+
20a	Adapter (External Flush), O-ring or Quad Ring		106020+	106021+	106022+	106023+	106024+	128651+
20b	Adapter, Wiping Stem Seal		119467+	119468+	119469+	119470+	119471+	POA
* 21a	O-ring, Upper Stem (qty 3 required)	EPDM	E70210	E70210	E70214	E70214	E70214	N/A
		FKM	V70210	V70210	V70214	V70214	V70214	N/A
* 21c	Quad Ring, Upper Stem (qty 3 req)	EPDM	121300+	121300+	124163+	124163+	124163+	114221+
		FKM	124088+	124088+	121299+	121299+	121299+	114223+
* 21b	Wiping Stem Seal, Upper	EPDM	116183+	116183+	116184+	116184+	116184+	POA
		FKM	115626+	115626+	116185+	116185+	116185+	POA
* 25	O-ring, Flush	EPDM	E70010	E70010	E70111	E70111	E70111	E70111
		FKM	V70010	V70010	V70111	V70111	V70111	V70111
* 26	O-ring, Outer Stem (not shown, qty 2)	Nitrile	N90016	N90016	N90020	N90020	N90020	N90020

Notes:

PL5027-CH50a

* Recommended Spare Parts

*** See actuator parts lists

1. For items 8 and 16, see W71 Mix Proof Seat Lift with External Flush Valve Stems Chart.
2. For one-piece body, qty. 2 are required for item 6 and item 18; for a clamped body, qty. 3 are required.
4. Unless otherwise noted, quantity required is 1.
6. POA = Part # on availability; N/A = not available with this design.

W71 Mix Proof Seat Lift Valve with Steam Adapter

Item #	Part Description		1-1/2"	2"	2-1/2"	3"	4"	6"
1	Control Top	Contact Factory						
3	Actuator	***						
* 4	O-ring (not shown)	Nitrile	N70010	N70010	N70111	N70111	N70111	N70111
* 5	Bearing, Upper Adapter		102757+	102757+	106047+	106047+	106047+	101995+
* 6	O-ring, Body (see note 2)	EPDM	E70223	E70228	E70232	E70236	E70244	E70258
		FKM	V70223	V70228	V70232	V70236	V70244	V70258
8	Stem, Upper Assembly - See note 1, below							
* 10a	Seat Ring -Tri Ring, Upper	EPDM	106031+	102736+	107048+	102488+	102491+	102738+
		FKM	107990+	107980+	107982+	107974+	107977+	108020+
* 11	Seat Ring -Tri Ring, Vent	EPDM	106041+	107693+	107696+	107697+	102490+	102737+
		FKM	107992+	107984+	107987+	107988+	107976+	108019+
* 12a	Seat Ring -Tri Ring, Lower	EPDM	106036+	107693+	102487+	102489+	102492+	102739+
		FKM	107991+	107984+	107973+	107975+	107978+	108021+
* 14a	Quad Ring, Lower (qty 2 req)	EPDM	E70322	E70327	E70331	E70335	E70342	N/A
		FKM	V70322	V70327	V70331	V70335	V70342	N/A
* 15	Bearing, Lower Seal Retainer		101947+	102000+	106049+	106048+	102003+	POA
16	Stem, Lower Assembly - See note 1, below							
17a	Seal Retainer, Lower Flush, Quad Ring		POA	117728+	122609+	117736+	118364+	POA
18	Clamp		119-30	119-33	119-34	119-51	119-87	119-123
19	Spray Bushing		106030+	106030+	107950+	107950+	107950+	107950+
20a/c	Adapter, O-ring or Quad Ring		POA	117741+	114925+	117742+	114927+	POA
* 21a	O-ring, Upper Stem (qty 2 req)	EPDM	E70210	E70210	E70214	E70214	E70214	N/A
		FKM	V70210	V70210	V70214	V70214	V70214	N/A
* 21c	Quad Ring, Upper Stem (qty 2 req)	EPDM	121300+	121300+	124163+	124163+	124163+	114221+
		FKM	124088+	124088+	121299+	121299+	121299+	114223+
* 25	O-ring, Flush (not shown)	EPDM	E70010	E70010	E70111	E70111	E70111	E70111
		FKM	V70010	V70010	V70111	V70111	V70111	V70111
* 26	O-ring, Outer Stem (qty 2 req)	Nitrile	N90016	N90016	N90020	N90020	N90020	N90020

Notes:

PL5027-CH87a

- * Recommended Spare Parts
- *** See actuator parts lists
- 1. For items 8 and 16, see W71 Mix Proof Seat Lift with Steam Adapter Valve Stems Chart.
- 2. For one-piece body, qty. 2 are required for item 6 and item 18; for a clamped body, qty. 3 are required.
- 4. Unless otherwise noted, quantity required is 1.
- 5. **EPDM recommended on all steam-contact seals.**
- 6. POA = Part # on availability; N/A = not available with this design.

W72RS Mix Proof Non-Seat Lift Valve

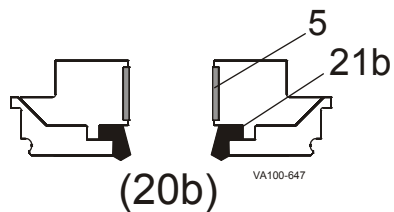
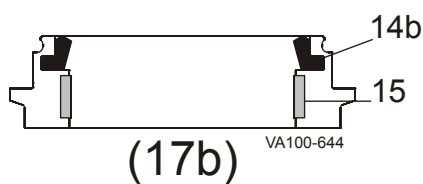
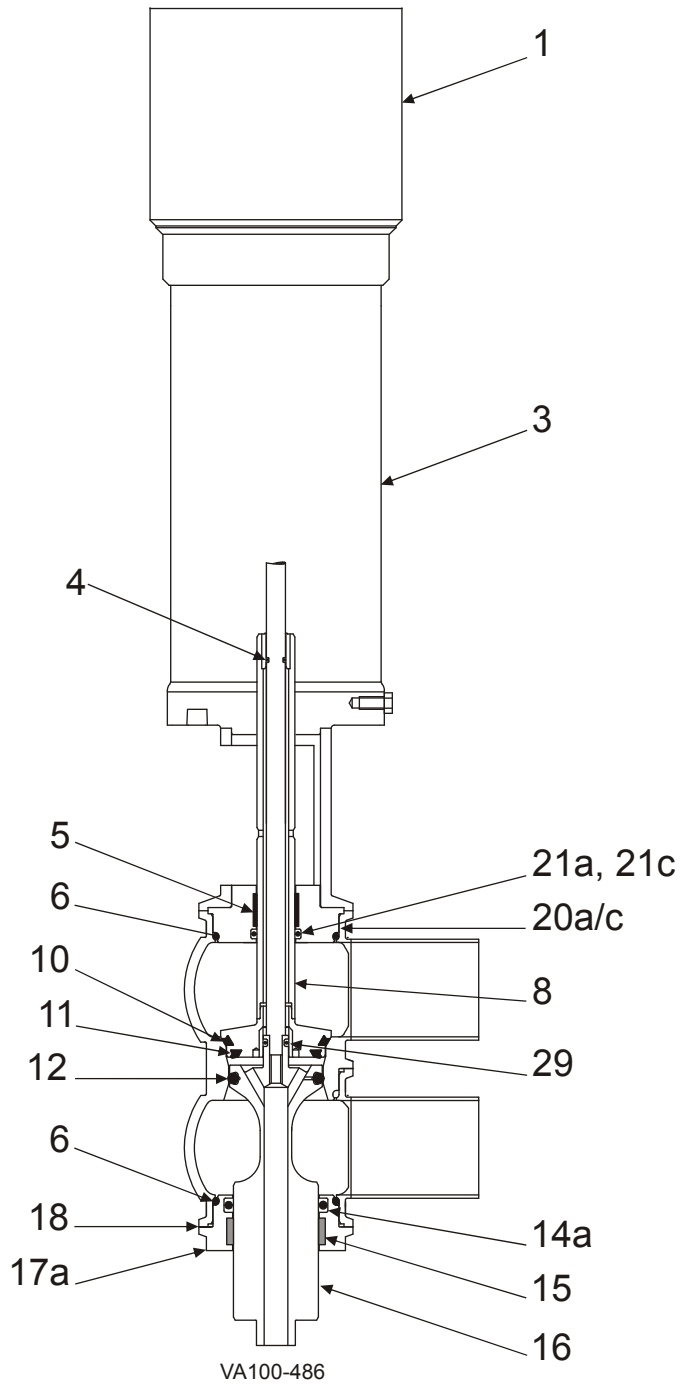

W72RS Mix Proof Non-Seat Lift Valve

Item #	Part Description	1-1/2"	2"	2-1/2"	3"	4"	6"
1	Control Top	Contact Factory ***					
3	Actuator						
* 4	O-ring, Inner Stem Nitrile	N70010	N70010	N70111	N70111	N70111	N70111
* 5	Bearing, Upper Adapter	102757+	102757+	106047+	106047+	106047+	101995+
* 6	O-ring, Body (see note 2) EPDM	E70223	E70228	E70232	E70236	E70244	E70258
		FKM	V70223	V70228	V70232	V70236	V70244
8	Stem, Upper - See note 1, below						
* 10	Seat Ring - Tri Ring, Upper EPDM	106031+	102736+	107048+	102488+	102491+	102738+
		FKM	107990+	107980+	107982+	107974+	107977+
* 11	Seat Ring - Tri Ring, Vent EPDM	106041+	107693+	107696+	107697+	102490+	102737+
		FKM	107992+	107984+	107987+	107988+	107976+
* 12	Seat Ring - Radial O-ring, Lower EPDM	E80319	E80325	E80329	E80333	E80340	E80354
		FKM	V80319	V80325	V80329	V80333	V80340
* 14a	Quad Ring, Lower EPDM	N/A	N/A	117992+	117561+	116952+	122350+
		FKM	N/A	35414+	117993+	117562+	116953+
* 14b	Wiping Stem Seal, Lower EPDM	116186+	116188+	116190+	116195+	116199+	POA
		FKM	116187+	116189+	116191+	116196+	116200+
* 15	Bearing, Lower Seal Retainer	101947+	102000+	106049+	106048+	102003+	102004+
16	Stem, Lower Assembly - See note 1, below						
17a	Seal Retainer, Quad Ring	106066+	106067+	106068+	106069+	106070+	125047+
17b	Seal Retainer, Wiping Stem Seal	117444+	117445+	117446+	117447+	117448+	POA
18	Clamp	119-30	119-33	119-34	119-51	119-87	119-123
20a/c	Adapter	111043+	111017+	111196+	111026+	111029+	123970+
20b	Adapter, Wiping Stem Seal	119482+	119483+	119484+	119485+	119486+	POA
* 21a	O-ring, Upper Stem EPDM	E70210	E70210	E70214	E70214	E70214	N/A
		FKM	V70210	V70210	V70214	V70214	V70214
* 21c	Quad Ring, Upper Stem EPDM	121300+	121300+	124163+	124163+	124163+	114221+
		FKM	124088+	124088+	121299+	121299+	121299+
* 21b	Wiping Stem Seal, Upper EPDM	116183+	116183+	116184+	116184+	116184+	POA
		FKM	115626+	115626+	116185+	116185+	116185+
* 29	O-ring, Non-Flush EPDM	E70109	E70109	E70113	E70113	E70113	E70113
		FKM	V70109	V70109	V70113	V70113	V70113

* Recommended Spare Parts

PL5027-CH51

*** See actuator parts lists

1. For items 8 and 16, see W72RS Mix Proof Non-Seat Lift Valve Stems Chart.
2. For one-piece body, qty. 2 are required for item 6 and item 18; for a clamped body, qty. 3 are required.
4. Unless otherwise noted, quantity required is 1.
6. POA = Part # on availability; N/A = not available with this design.

W72RS Mix Proof Non-Seat Lift Valve with External Flush

Item #	Part Description	1-1/2"	2"	2-1/2"	3"	4"	6"
1	Control Top	Contact Factory					
3	Actuator	***					
* 4	O-ring, Inner Stem (not shown)	Nitrile	N70010	N70010	N70111	N70111	N70111
* 5	Bearing, Upper Adapter		102757+	102757+	106047+	106047+	101995+
* 6	O-ring, Body (see note 2)	EPDM	E70223	E70228	E70232	E70236	E70244
		FKM	V70223	V70228	V70232	V70236	V70244
8	Stem, Upper Assembly - See note 1, below						
* 10	Seat Ring - Tri Ring, Upper	EPDM	106031+	102736+	107048+	102488+	102491+
		FKM	107990+	107980+	107982+	107974+	107977+
* 11	Seat Ring - Tri Ring, Vent	EPDM	106041+	107693+	107696+	107697+	102490+
		FKM	107992+	107984+	107987+	107988+	107976+
* 12	Seat Ring - Radial O-ring, Lower	EPDM	E80319	E80325	E80329	E80333	E80340
		FKM	V80319	V80325	V80329	V80333	V80340
* 14a	Quad Ring, Lower	EPDM	122689+	35413+	34429+	117561+	116952+
		FKM	122690+	35414+	35415+	117562+	116953+
* 14b	Wiping Stem Seal, Lower	EPDM	116186+	116188+	116198+	116195+	116199+
		FKM	116187+	116189+	116191+	116196+	116200+
* 15	Bearing, Lower Seal Retainer		101947+	102000+	106049+	106048+	102003+
16a	Stem, Lower Assembly - See note 1, below						
16b	Stem, Lower Flush - See note 1, below						
17a	Seal Retainer, Quad Ring		106066+	106067+	106068+	106069+	106070+
17b	Seal Retainer, Wiping Stem Seal		117444+	117445+	117446+	117447+	117448+
17c	Seal Retainer, Lower Flush, Quad Ring		121374+	117728+	122609+	117736+	118364+
17d	Seal Retainer, Lower Flush, Wiping Stem Seal		119050+	119035+	118226+	117559+	118253+
18	Clamp		119-30	119-33	119-34	119-51	119-87
19	Spray Bushing		106030+	106030+	118210+	118210+	118210+
20a/c	Adapter		106020+	106021+	106022+	106023+	106024+
20b	Adapter, Wiping Stem Seal		119467+	119468+	119469+	119470+	119471+
* 21a	O-ring, Upper Stem (qty 3 req)	EPDM	E70210	E70210	E70214	E70214	E70214
		FKM	E70210	V70210	V70214	V70214	V70214
* 21c	Quad Ring, Upper Stem (qty 3 req)	EPDM	121300+	121300+	124163+	124163+	124163+
		FKM	124088+	124088+	121299+	121299+	121299+
* 21b	Wiping Stem Seal, Upper (qty 3 req)	EPDM	116183+	116183+	116184+	116184+	116184+
		FKM	115626+	115626+	116185+	116185+	116185+
24	Stem, Actuator, NSL Flush - See note 1, below						
* 25	O-ring, Flush	EPDM	E70010	E70010	E70111	E70111	E70111
		FKM	V70010	V70010	V70111	V70111	V70111

Notes:

PL5027-CH52

- * Recommended Spare Parts
- *** See actuator parts lists
- 1. For items 8, 16, and 24, see W72RS Mix Proof Non-Seat Lift with External Flush Valve Stems Chart.
- 2. For one-piece body, qty. 2 are required for item 6 and item 18; for a clamped body, qty. 3 are required.
- 4. Unless otherwise noted, quantity required is 1.
- 6. POA = Part # on availability; N/A = not available with this design.

W72RS Mix Proof Non-Seat Lift Valve with Steam Adapter

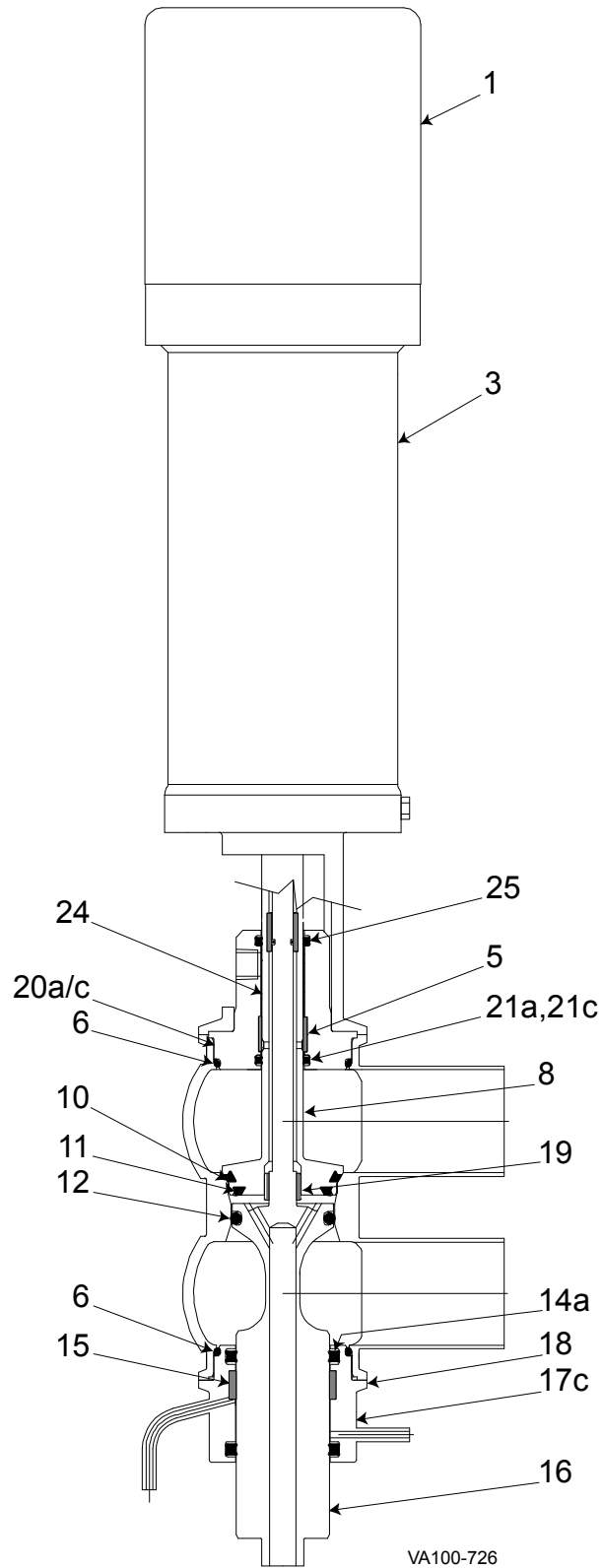

W72RS Mix Proof Non-Seat Lift Valve with Steam Adapter

Item #	Part Description		1-1/2"	2"	2-1/2"	3"	4"	6"
1	Control Top		Contact Factory					
3	Actuator		***					
* 4	O-ring (not shown)	Nitrile	N70010	N70010	N70111	N70111	N70111	N70111
* 5	Bearing		102757+	102757+	106047+	106047+	106047+	101995+
* 6	O-ring, Body (see note 2)	EPDM	E70223	E70228	E70232	E70236	E70244	E70258
		FKM	V70223	V70228	V70232	V70236	V70244	V70258
8	Stem, Upper Assembly - See note 1, below							
* 10	Seat Ring - Tri Ring, Upper	EPDM	106031+	102736+	107048+	102488+	102491+	102738+
		FKM	107990+	107980+	107982+	107974+	107977+	108020+
* 11	Seat Ring - Tri Ring, Vent	EPDM	106041+	107693+	107696+	107697+	102490+	102737+
		FKM	107992+	107984+	107987+	107988+	107976+	108019+
* 12	Seat Ring - O-ring, Lower	EPDM	E80319	E80325	E80329	E80333	E80340	E80354
		FKM	V80319	V80325	V80329	V80333	V80340	V80354
* 14a	Quad Ring, Lower (qty 2 req)	EPDM	122690+	35413+	34429+	117561+	116952+	122350+
		FKM	122689+	35414+	35415+	117562+	116953+	122351+
* 15	Bearing, Lower Seal Retainer		101947+	102000+	106049+	106048+	102003+	102004+
16	Stem, Lower Assembly - See note 1, below							
17c	Seal Retainer, Lower Flush, Quad Ring		POA	117728+	122609+	117736+	118364+	POA
18	Clamp		119-30	119-33	119-34	119-51	119-87	119-123
19	Spray Bushing		106030+	106030+	118210+	118210+	118210+	118210+
20a/c	Adapter, O-ring or Quad Ring		POA	114924+	114925+	117742+	114927+	POA
* 21a	O-ring, Upper Stem (qty 2 req)	EPDM	E70210	E70210	E70214	E70214	E70214	N/A
		FKM	E70210	V70210	V70214	V70214	V70214	N/A
* 21c	Quad Ring, Upper Stem (qty 2 req)	EPDM	121300+	121300+	124163+	124163+	124163+	114221+
		FKM	124088+	124088+	121299+	121299+	121299+	114223+
24	Stem, Actuator, NSL Flush - See note 1, below							
* 25	O-ring, Flush	EPDM	E70010	E70010	E70111	E70111	E70111	E70111
		FKM	V70010	V70010	V70111	V70111	V70111	V70111

Notes:

PL5027-CH88

- * Recommended Spare Parts
- *** See actuator parts lists
- 1. For items 8, 16, and 24, see W72RS Mix Proof Non-Seat Lift with External Flush Valve Stems Chart.
- 2. For one-piece body, qty. 2 are required for item 6 and item 18; for a clamped body, qty. 3 are required.
- 3. **EPDM recommended on all steam-contact seals.**
- 4. Unless otherwise noted, quantity required is 1.
- 6. POA = Part # on availability; N/A = not available with this design.

W72RS Mix Proof Seat Lift Valve

Item #	Part Description	1-1/2"	2"	2-1/2"	3"	4"	6"
1	Control Top	Contact Factory					
3	Actuator	***					
* 4	O-ring, Outer Stem (qty 2 req) Nitrile	N90016	N90016	N90020	N90020	N90020	N90020
* 5	Bearing, Upper Adapter	102757+	102757+	106047+	106047+	106047+	101995+
* 6	O-ring, Body (see note 2) EPDM	E70223	E70228	E70232	E70236	E70244	E70258
	FKM	V70223	V70228	V70232	V70236	V70244	V70258
8	Stem, Upper Assembly - See note 1, below						
* 10	Seat Ring - Tri Ring, Upper EPDM	106031+	102736+	107048+	102488+	102491+	102738+
	FKM	107990+	107980+	107982+	107974+	107977+	108020+
* 11	Seat Ring - Tri Ring, Vent EPDM	106041+	107693+	107696+	107697+	102490+	102737+
	FKM	107992+	107984+	107987+	107988+	107976+	108019+
* 12	Seat Ring - O-ring, Lower EPDM	E80319	E80325	E80329	E80333	E80340	E80354
	FKM	V80319	V80325	V80329	V80333	V80340	V80354
* 14a	Quad Ring, Lower EPDM	122689+	35413+	117992+	117561+	116952+	122350+
	FKM	122690+	35414+	117993+	117562+	116953+	122351+
* 14b	Wiping Stem Seal, Lower EPDM	116186+	116188+	116190+	116195+	116199+	POA
	FKM	116187+	116189+	116191+	116196+	116200+	POA
* 15	Bearing, Lower Seal Retainer	101947+	102000+	106049+	106048+	102003+	102004+
16	Stem, Lower Assembly - See note 1, below						
17a	Seal Retainer, Quad Ring	106066+	106067+	106068+	106069+	106070+	125047+
17b	Seal Retainer, Wiping Stem Seal	117444+	117445+	117446+	117447+	117448+	POA
18	Clamp	119-30	119-33	119-34	119-51	119-87	119-123
20a/c	Adapter, O-ring or Quad Ring	111043+	111017+	111196+	111026+	111029+	123970+
20b	Adapter, Wiping Stem Seal	119441+	119442+	119443+	119444+	119445+	POA
* 21a	O-ring, Upper Stem EPDM	E70210	E70210	E70214	E70214	E70214	N/A
	FKM	V70210	V70210	V70214	V70214	V70214	N/A
* 21c	Quad Ring, Upper Stem EPDM	121300+	121300+	124163+	124163+	124163+	114221+
	FKM	124088+	124088+	121299+	121299+	121299+	114223+
* 21b	Wiping Stem Seal, Upper EPDM	116183+	116183+	116184+	116184+	116184+	POA
	FKM	115626+	115626+	116185+	116185+	116185+	POA
* 29	O-ring, Non-Flush EPDM	E70109	E70109	E70113	E70113	E70113	E70113
	FKM	V70109	V70109	V70113	V70113	V70113	V70113

* Recommended Spare Parts

PL5027-CH53

*** See actuator parts lists

1. For items 8 and 16, see W72RS Mix Proof Seat Lift Valve Stems Chart.
2. For one-piece body, qty. 2 are required for item 6 and item 18; for a clamped body, qty. 3 are required.
4. Unless otherwise noted, quantity required is 1.
6. POA = Part # on availability; N/A = not available with this design.

W72RS Mix Proof Seat Lift Valve with External Flush

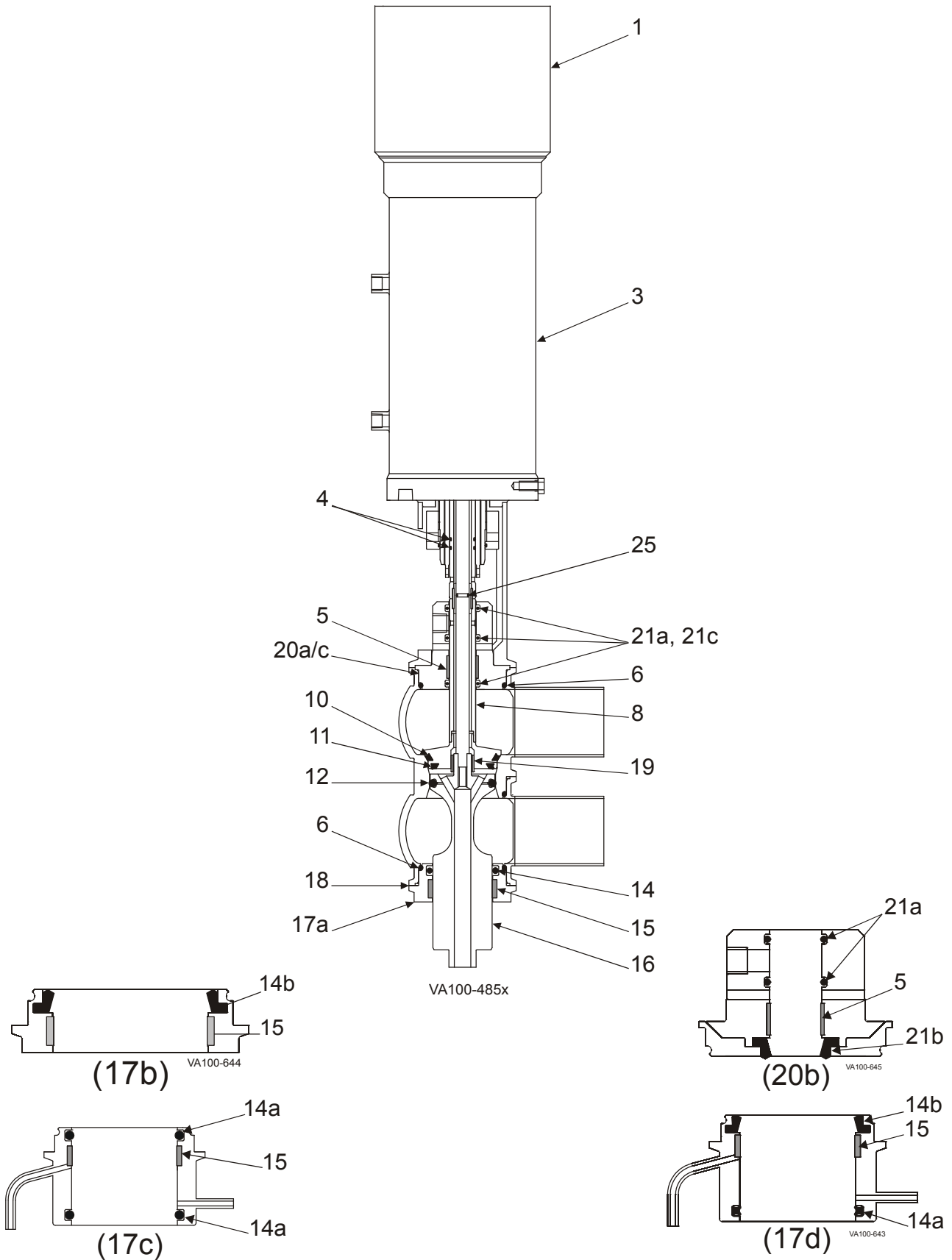

W72RS Mix Proof Seat Lift Valve with External Flush

Item #	Part Description	1-1/2"	2"	2-1/2"	3"	4"	6"
1	Control Top	Contact Factory					
3	Actuator	***					
* 4	O-ring, Outer Stem (qty 2 req) Nitrile	N90016	N90016	N90020	N90020	N90020	N90020
* 5	Bearing, Upper Adapter	102757+	102757+	106047+	106047+	106047+	101995+
* 6	O-ring, Body (see note 2) EPDM	E70223	E70228	E70232	E70236	E70244	E70258
	FKM	V70223	V70228	V70232	V70236	V70244	V70258
8	Stem, Upper Assembly - See note 1, below						
* 10	Seat Ring - Tri Ring, Upper EPDM	106031+	102736+	107048+	102488+	102491+	102738+
	FKM	107990+	107980+	107982+	107974+	107977+	108020+
* 11	Seat Ring - Tri Ring, Vent EPDM	106041+	107693+	107696+	107697+	102490+	102737+
	FKM	107992+	107984+	107987+	107988+	107976+	108019+
* 12	Seat Ring - O-ring, Lower EPDM	E80319	E80325	E80329	E80333	E80340	E80354
	FKM	V80319	V80325	V80329	V80333	V80340	V80354
* 14a	Quad Ring, Lower EPDM	122690+	35413+	117992+	117561+	116952+	122350+
	FKM	122689+	35414+	117993+	117562+	116953+	122351+
* 14b	Wiping Stem Seal, Lower EPDM	116186+	116188+	116190+	116195+	116199+	POA
	FKM	116187+	116189+	116191+	116196+	116200+	POA
* 15	Bearing, Lower Seal Retainer	101947+	102000+	106049+	106048+	102003+	102004+
16	Stem, Lower Assembly - See note 1, below						
17a	Seal Retainer, Quad Ring	106066+	106067+	106068+	106069+	106070+	125047+
17b	Seal Retainer, Wiping Stem Seal	117444+	117445+	117446+	117447+	117448+	POA
17c	Seal Retainer, Lower Flush, Quad Ring	114918+	117728+	114920+	117736+	118364+	POA
17d	Seal Retainer, Lower Flush, Wiping Stem Seal	119050+	119036+	118226+	117559+	118253+	POA
18	Clamp	119-30	119-33	119-34	119-51	119-87	119-123
19	Spray Bushing	106030+	106030+	118210+	118210+	118210+	118210+
20a/c	Adapter, O-ring or Quad Ring	106020+	106021+	106022+	106023+	106024+	128651+
20b	Adapter, Wiping Stem Seal	119467+	119468+	119469+	119470+	119471+	POA
* 21a	O-ring, Upper Stem (qty 3 req) EPDM	E70210	E70210	E70214	E70214	E70214	N/A
	FKM	V70210	V70210	V70214	V70214	V70214	N/A
* 21c	Quad Ring, Upper Stem (qty 3 req) EPDM	121300+	121300+	124163+	124163+	124163+	114221+
	FKM	124088+	124088+	121299+	121299+	121299+	114223+
* 21b	Wiping Stem Seal, Upper EPDM	116183+	116183+	116184+	116184+	116184+	POA
	FKM	115626+	115626+	116185+	116185+	116185+	POA
* 25	O-ring, Flush EPDM	E70010	E70010	E70111	E70111	E70111	E70111
	FKM	V70010	V70010	V70111	V70111	V70111	V70111

Notes:

PL5027-CH54

* Recommended Spare Parts

*** See actuator parts lists

1. For items 8 and 16, see W72RS Mix Proof Seat Lift with External Flush Valve Stems Chart.
2. For one-piece body, qty. 2 are required for item 6 and item 18; for a clamped body, qty. 3 are required.
4. Unless otherwise noted, quantity required is 1.
6. POA = Part # on availability; N/A = not available with this design.

W72RS Mix Proof Seat Lift Valve with Steam Adapter

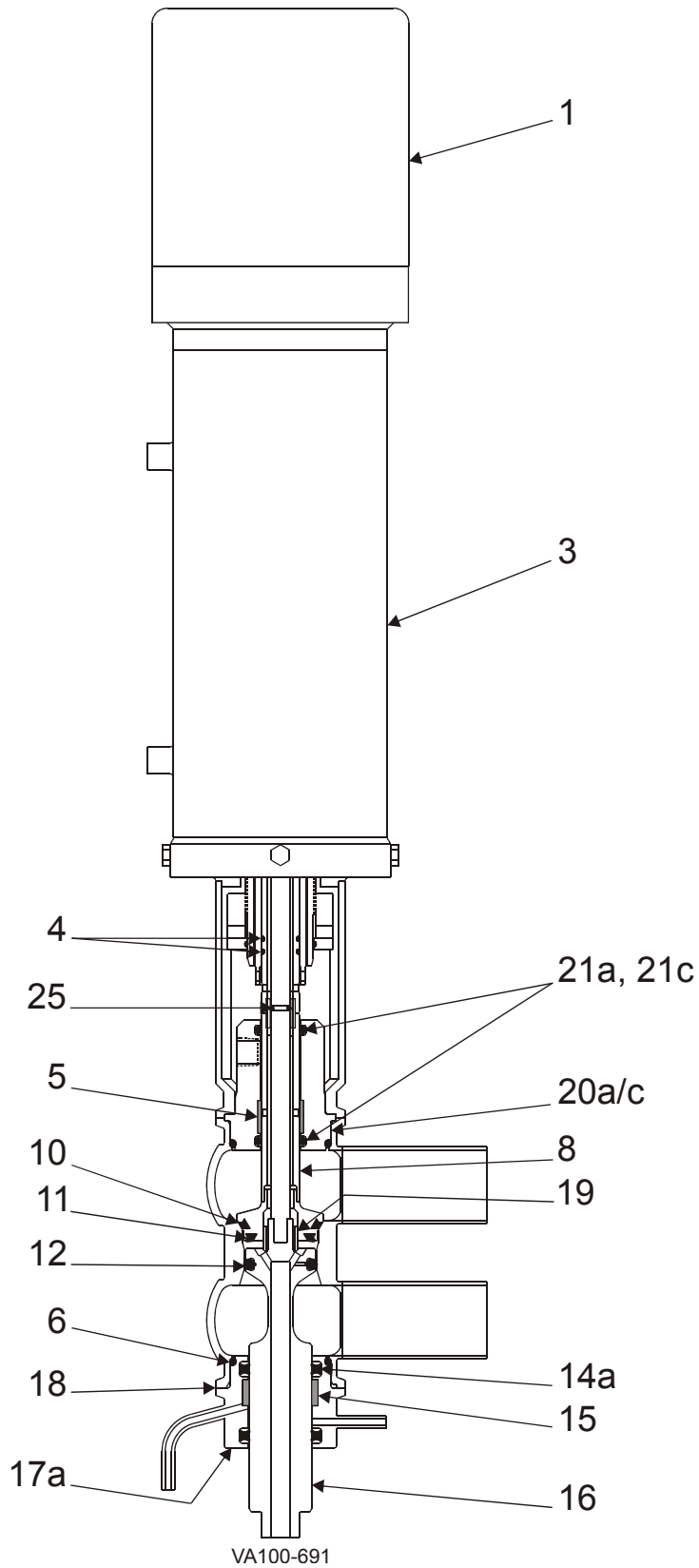

W72RS Mix Proof Seat Lift Valve with Steam Adapter

Item #	Part Description	1-1/2"	2"	2-1/2"	3"	4"	6"
1	Control Top	Contact Factory					
3	Actuator	***					
* 4	O-ring, Outer Stem (qty 2 req) Nitrile	N90016	N90016	N90020	N90020	N90020	N90020
* 5	Bearing, Upper Adapter	102757+	102757+	106047+	106047+	106047+	101995+
* 6	O-ring, Body (see note 2) EPDM	E70223	E70228	E70232	E70236	E70244	E70258
		FKM	V70223	V70228	V70232	V70236	V70244
8	Stem, Upper Assembly - See note 1, below						
* 10	Seat Ring - Tri Ring, Upper EPDM	106031+	102736+	107048+	102488+	102491+	102738+
		FKM	107990+	107980+	107982+	107974+	107977+
* 11	Seat Ring - Tri Ring, Vent EPDM	106041+	107693+	107696+	107697+	102490+	102737+
		FKM	107992+	107984+	107987+	107988+	107976+
* 12	Seat Ring - O-ring, Lower EPDM	E80319	E80325	E80329	E80333	E80340	E80354
		FKM	V80319	V80325	V80329	V80333	V80340
* 14a	Quad Ring, Lower (qty 2 req) EPDM	122690+	35413+	117992+	117561+	116952+	122350+
		FKM	122689+	35414+	35415+	117562+	116953+
* 15	Bearing, Lower Seal Retainer	101947+	102000+	106049+	106048+	102003+	POA
16	Stem, Lower Assembly - See note 1, below						
17a	Seal Retainer, Lower Flush, Quad Ring	114918+	117728+	114920+	117736+	118364+	POA
18	Clamp	119-30	119-33	119-34	119-51	119-87	119-123
19	Spray Bushing	106030+	106030+	118210+	118210+	118210+	118210+
20a/c	Adapter, O-ring or Quad Ring	114923+	114924+	114925+	117742+	114927+	POA
* 21a	O-ring, Upper Stem (qty 2 req) EPDM	E70210	E70210	E70214	E70214	E70214	N/A
		FKM	V70210	V70210	V70214	V70214	V70214
* 21c	Quad Ring, Upper Stem (qty 2 req) EPDM	121300+	121300+	124163+	124163+	124163+	114221+
		FKM	124088+	124088+	121299+	121299+	121299+
* 25	O-ring, Flush (not shown) EPDM	E70010	E70010	E70111	E70111	E70111	E70111
		FKM	V70010	V70010	V70111	V70111	V70111

Notes:

PL5027-CH89

- * Recommended Spare Parts
- *** See actuator parts lists
- 1. For items 8 and 16, see W72RS Mix Proof Seat Lift with Steam Adapter Valve Stems Chart.
- 2. For one-piece body, qty. 2 are required for item 6 and item 18; for a clamped body, qty. 3 are required.
- 4. Unless otherwise noted, quantity required is 1.
- 5. **EPDM recommended on all steam-contact seals.**
- 6. POA = Part # on availability; N/A = not available with this design.

W72RS Mix Proof Seat Lift Valve with Upper Balancer Option

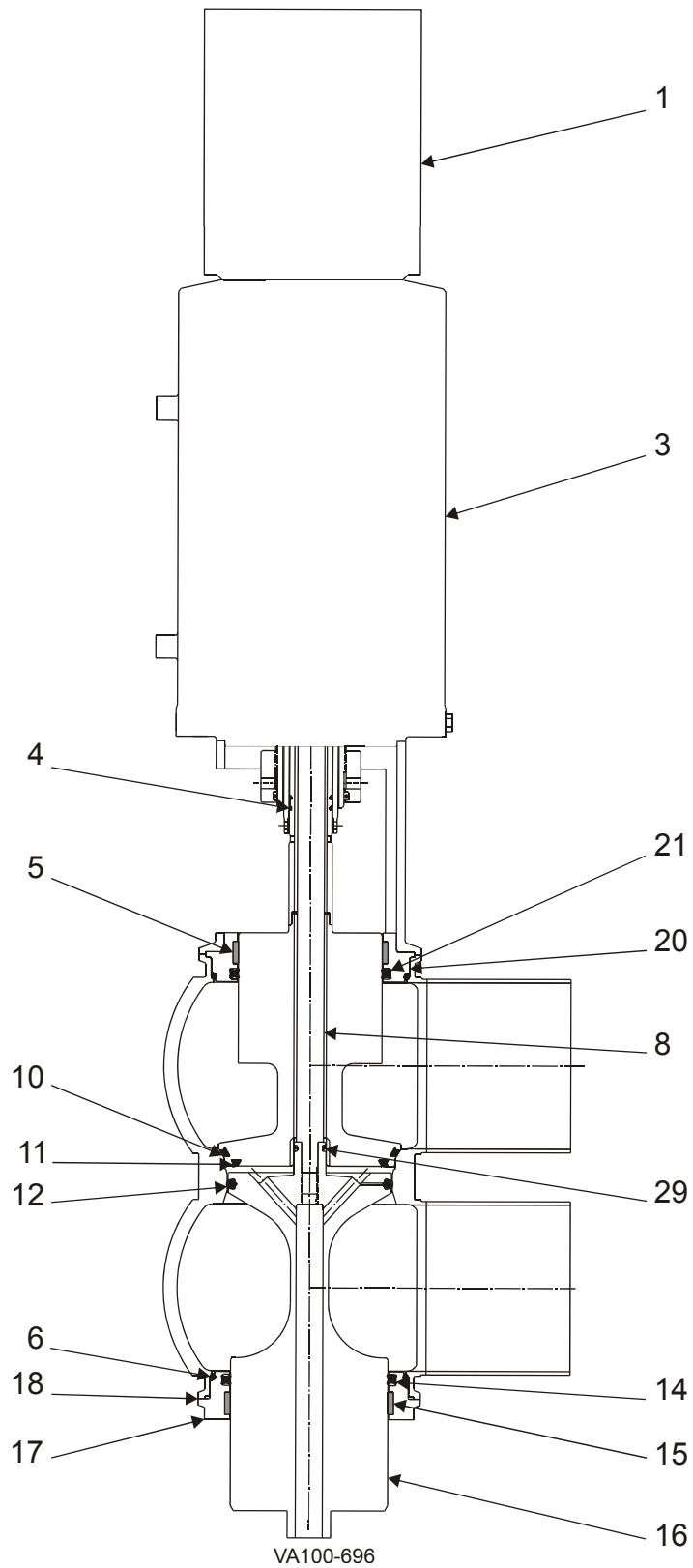

W72RS Mix Proof Seat Lift Valve with Upper Balancer Option

Item #	Part Description		2"	2-1/2"	3"	4"
1	Control Top		Contact Factory			
3	Actuator		***			
* 4	O-ring, Outer Stem	Nitrile	N90016	N90020	N90020	N90020
* 5	Bearing, Upper Adapter		126066+	126771+	102002+	126069+
* 6	O-ring, Body (see note 2)	EPDM	E70228	E70232	E70236	E70244
		FKM	V70228	V70232	V70236	V70244
8	Stem, Upper Assembly - See note 1, below					
* 10	Seat Ring - Tri Ring, Upper	EPDM	102736+	107048+	102488+	102491+
		FKM	107980+	107982+	107974+	107977+
* 11	Seat Ring - Tri Ring, Vent	EPDM	107693+	107696+	107697+	102490+
		FKM	107984+	107987+	107988+	107976+
* 12	Seat Ring - Radial O-ring, Lower	EPDM	E80325	E80329	E80333	E80340
		FKM	V80325	V80329	V80333	V80340
* 14a	Quad Ring, Lower	EPDM	122689+	35415+	117561+	116952+
		FKM	122690+	35429+	117562+	116953+
* 15	Bearing, Lower Seal Retainer		102000+	106049+	106048+	102003+
16	Stem, Lower Assembly - See note 1, below					
17a	Seal Retainer, Quad Ring		106067+	106068+	106069+	106070+
18	Clamp		119-33	119+34	119-51	119-87
20a	Adapter, O-ring or Quad Ring		126041+	128440+	126050+	126057+
* 21a	Quad Ring, Upper Stem	EPDM	126065+	128579+	116954+	126071+
		FKM	126064+	128580+	116955+	126070+
* 29	O-ring, Non-Flush	EPDM	E70109	E70113	E70113	E70113
		FKM	V70109	V70113	V70113	V70113

* Recommended Spare Parts

PL5027-CH135

*** See actuator parts lists

1. For items 8 and 16, see W72RS Mix Proof Seat Lift with Upper Balancer Option Valve Stems Chart.
2. For one-piece body, qty. 2 are required for item 6 and item 18; for a clamped body, qty. 3 are required.
4. Unless otherwise noted, quantity required is 1.

W72RS Mix Proof Seat Lift Tank Outlet Valve

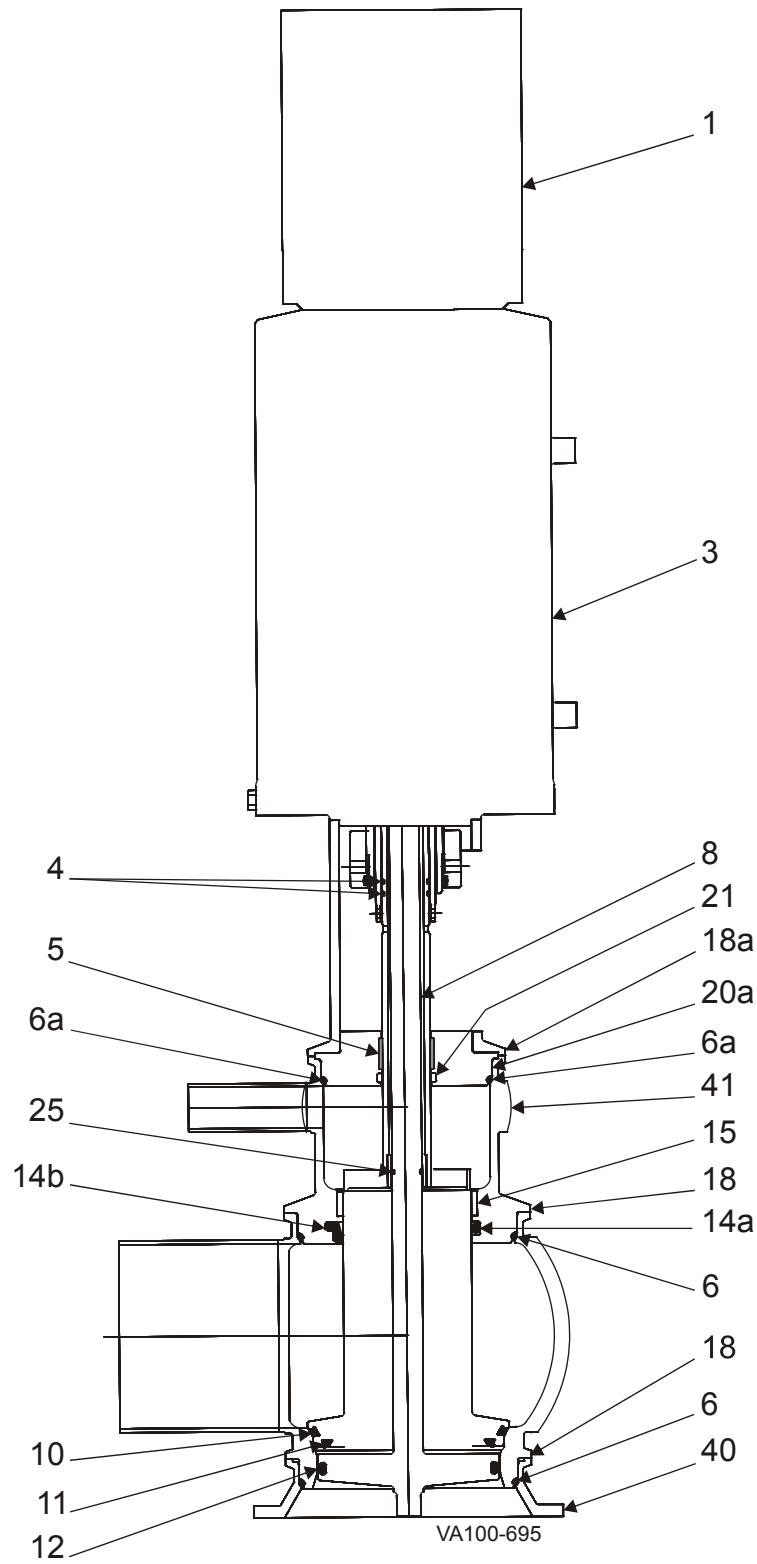

W72RS Mix Proof Seat Lift Tank Outlet Valve

Item #	Part Description		2-1/2"	3"	4"	6"
1	Control Top		Contact Factory			
3	Actuator Assembly		***			
* 4	O-ring, Outer Stem (qty 2 req)	Nitrile	N90020	N90020	N90020	N90020
* 5	Bearing, Adapter		106047+	106047+	106047+	POA
* 6	O-ring, Body (qty 2 req)	EPDM	E70323	E70236	E70244	E70258
		FKM	V70323	V70236	V70244	V70258
* 6a	O-ring, Leak Chamber	EPDM	E70323	E70232	E70236	POA
		FKM	V70323	V70232	V70236	POA
8	Stem, Outer (Pipe Side) - See note 1, below					
* 10	Seat Ring - Tri Ring, Pipe Side	EPDM	107048+	102488+	102491+	102738+
		FKM	107902+	107974+	107976+	108020+
* 11	Seat Ring - Tri Ring, Vent	EPDM	107696+	107697+	102490+	102737+
		FKM	107987+	107988+	107977+	108019+
* 12	Seat Ring - Radial O-ring, Tank Side	EPDM	E80329	E80333	E80340	E80354
		FKM	V80329	V80333	V80340	V80354
* 14a	Quad Ring, Leak Chamber	EPDM	34429+	34429+	117561+	POA
		FKM	35414+	35415+	117562+	POA
* 14b	Wiping Stem Seal, Leak Chamber	EPDM	116190+	116190+	116195+	POA
		FKM	116191+	116191+	116196+	POA
* 15	Bearing, Leak Chamber		106049+	106049+	106048+	POA
16	Stem, Inner (Tank Side) - See note 1, below					
18	Clamp (qty 2 req)		119-51	119-51	119-87	119-123
18a	Clamp, Leak Chamber		119-34	119-34	119-51	POA
20a	Adapter, O-ring		111196+	111196+	111026+	POA
* 21a	O-ring, Adapter	EPDM	E70214	E70214	E70214	POA
		FKM	V70214	V70214	V70214	POA
* 25	O-ring, Inner Stem	EPDM	E70111	E70111	E70111	E70111
		FKM	V70111	V70111	V70111	V70111
40	Tank Flange (see note 2)		114831+	114832+	114833+	POA
41a	Leak Chamber, Quad Ring		126804+	126805+	126802+	POA
41b	Leak Chamber, Wiping Stem Seal		126016+	125962+	126025+	POA

* Recommended Spare Parts

PL5027-CH134

*** See actuator parts lists

1. For items 8 and 16, see W72RS Mix Proof Seat Lift Tank Outlet Valve Stems Chart.
2. 1/4" tank flange must be ordered separately.

W72RS Mix Proof Seat Lift Tank Outlet Valve with External Flush

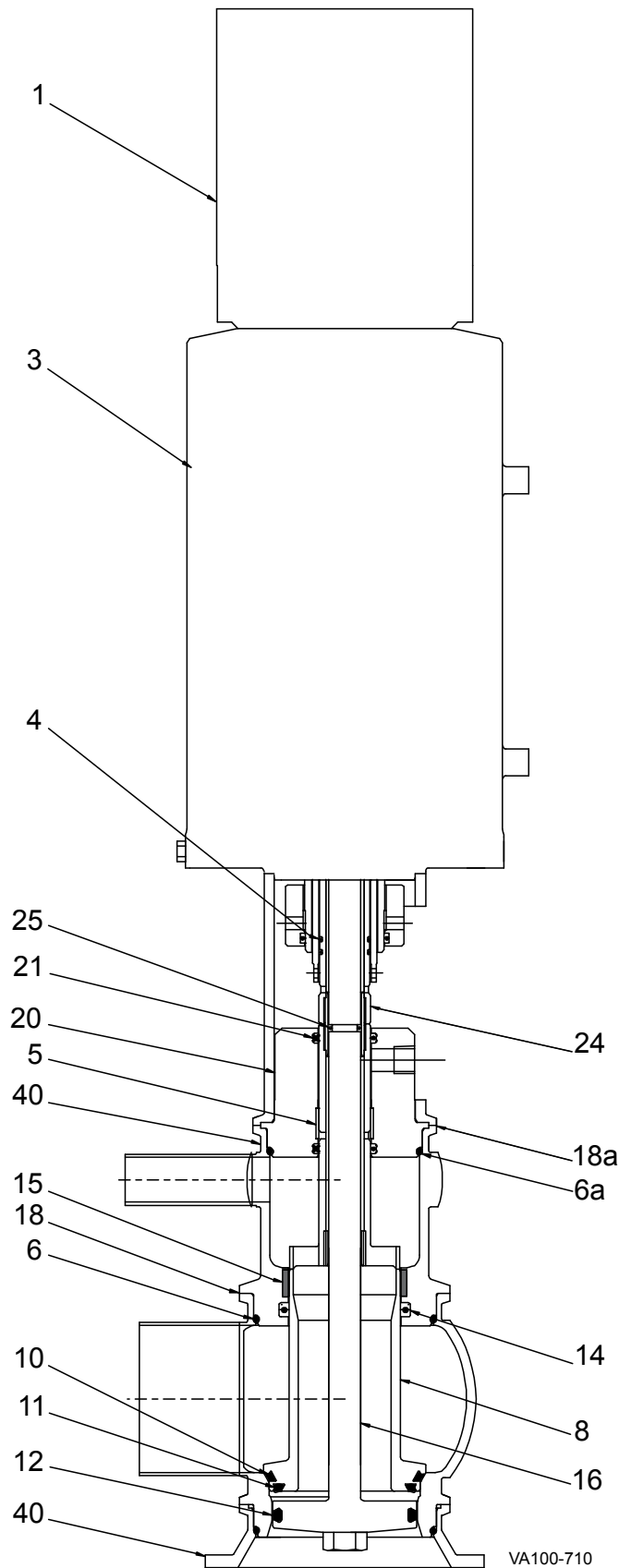

W72RS Mix Proof Seat Lift Tank Outlet Valve with External Flush

Item #	Part Description		2-1/2"	3"	4"	6"
1	Control Top					
3	Actuator Assembly		***			
* 4	O-ring, Outer Stem (qty 2 req)	Nitrile	N90020	N90020	N90020	N90020
* 5	Bearing, Adapter		106047+	106047+	106047+	POA
* 6	O-ring, Body (qty 2 req)	EPDM	E70323	E70236	E70244	E70258
		FKM	V70323	V70236	V70244	V70258
* 6a	O-ring, Leak Chamber	EPDM	E70232	E70232	E70236	POA
		FKM	V70232	V70232	V70236	POA
8	Stem, Outer (Pipe Side) - See note 1, below					
* 10	Seat Ring - Tri Ring, Pipe Side	EPDM	107048+	102488+	102491+	102738+
		FKM	107902+	107974+	107976+	108020+
* 11	Seat Ring - Tri Ring, Vent	EPDM	107696+	107697+	102490+	102737+
		FKM	107987+	107988+	107977+	108019+
* 12	Seat Ring - Radial O-ring, Tank Side	EPDM	E80329	E80333	E80340	E80354
		FKM	V80329	V80333	V80340	V80354
* 14	Quad Ring, Leak Chamber	EPDM	34429+	34429+	117561+	POA
		FKM	35414+	35415+	117562+	POA
* 15	Bearing, Leak Chamber		106049+	106049+	106048+	POA
16	Stem, Inner (Tank Side) - See note 1, below					
18	Clamp, Body (qty 2 req)		119-51	119-51	119-87	119-123
18a	Clamp, Leak Chamber		119-34	119-34	119-51	POA
20	Adapter, O-ring		POA	114925+	114926+	POA
* 21	O-ring, Adapter (qty 2 req)	EPDM	E70214	E70214	E70214	POA
		FKM	V70214	V70214	V70214	POA
24	Stem, Actuator - See note 1, below					
* 25	O-ring, Inner Stem	EPDM	E70111	E70111	E70111	E70111
		FKM	V70111	V70111	V70111	V70111
40	Tank Flange (see note 2)		114321+	114832+	114833+	POA
41	Leak Chamber, Quad Ring		126804+	126805+	126802+	POA

* Recommended Spare Parts

PL5027-CH148

*** See actuator parts lists

1. For items 8, 16, and 24, see W72RS Mix Proof Seat Lift Tank Outlet Valve with External Flush Stems Chart.
2. 1/4" tank flange must be ordered separately.
6. POA = Part # on availability; N/A = not available with this design.

W72RSP Mix Proof Seat Lift Valve

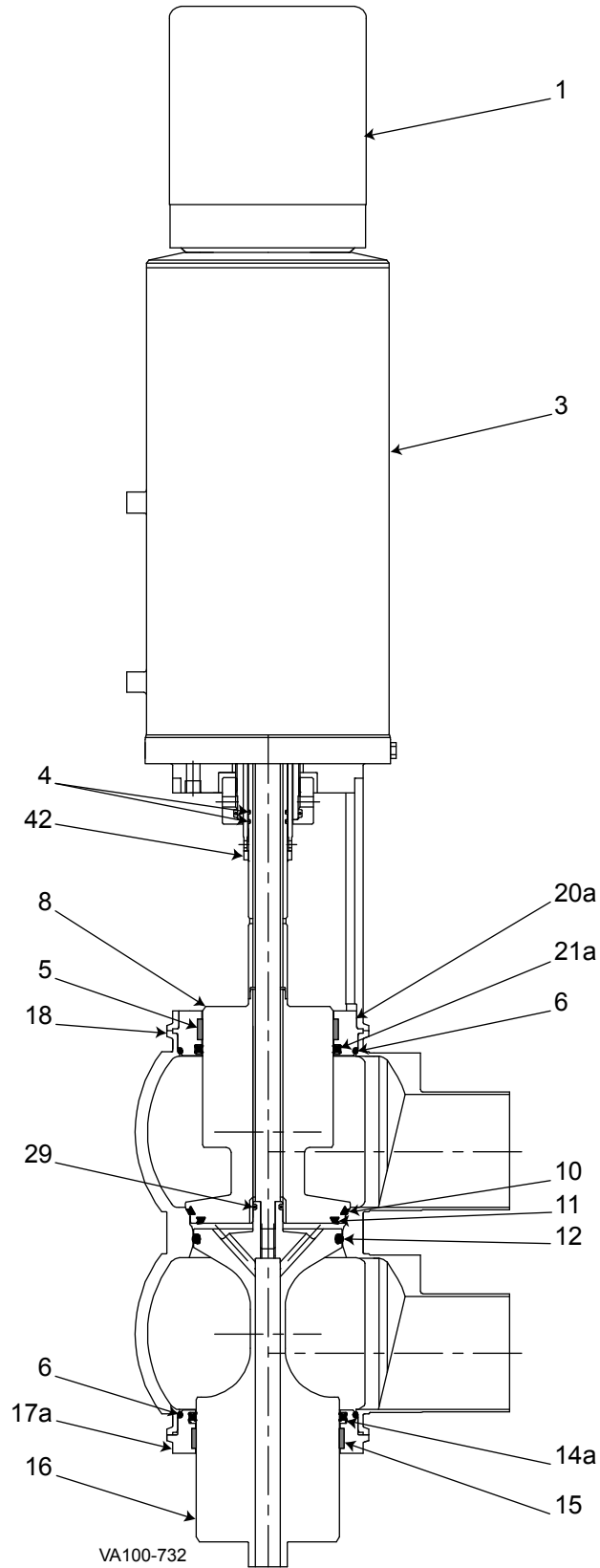

W72RSP Mix Proof Seat Lift Valve

Item #	Part Description	2.5"	3"	4"	6"
1	Control Top	Contact Factory			
3	Actuator	***			
* 4	O-ring, Outer Stem (qty 2 req) Nitrile	N90020	N90020	N90020	N90020
* 5	Bearing, Upper Adapter (qty 2 req)	126069+	126069+	126069+	POA
* 6	O-ring, Body (qty 2 req) EPDM	E70244	E70244	E70244	E70258
		FKM	V70244	V70244	V70244
8	Stem, Upper Assembly - See note 1, below				
* 10	Seat Ring - Tri Ring, Upper EPDM	102491+	102491+	102491+	102738+
		FKM	107977+	107977+	107977+
* 11	Seat Ring - Tri Ring, Vent EPDM	102490+	102490+	102490+	102737+
		FKM	107976+	107976+	107976+
* 12	Seat Ring - O-ring, Lower EPDM	E80340	E80340	E80340	E80354
		FKM	V80340	V80340	V80340
* 14a	Quad Ring, Lower EPDM	116952+	116952+	116952+	122350+
		FKM	116953+	116953+	116953+
* 15	Bearing, Lower Seal Retainer	102003+	102003+	102003+	102004+
16	Stem, Lower Assembly - See note 1, below				
17a	Seal Retainer, Quad Ring	106070+	106070+	106070+	125047+
18	Clamp (qty 2 required)	119-87	119-87	119-87	119-123
20a	Adapter, O-ring or Quad Ring	126877+	126877+	126877+	POA
* 21a	Quad Ring, Upper Stem EPDM	126071+	126071+	126071+	POA
		FKM	126070+	126070+	126070+
* 29	O-ring, Non-Flush EPDM	E70113	E70113	E70113	E70113
		FKM	V70113	V70113	V70113
42	Stop Ring	122357+	122357+	122357+	122357+

* Recommended Spare Parts

PL5027-CH162

*** See actuator parts lists

1. For items 8 and 16, see W72RSP Mix Proof Seat Lift Valve Stems Chart.

W72RSP Mix Proof Seat Lift Valve with External Flush

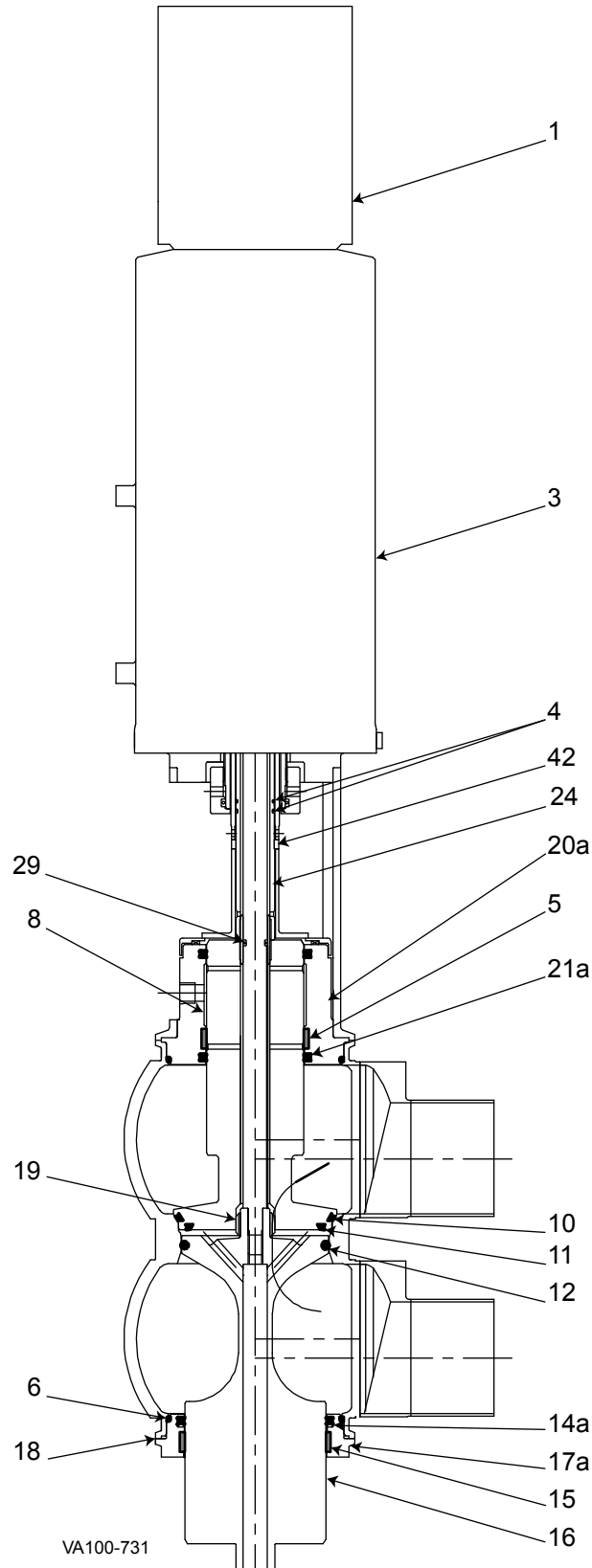

W72RSP Mix Proof Seat Lift Valve with External Flush

Item #	Part Description	2.5"	3"	4"	6"
1	Control Top	Contact Factory			
3	Actuator	***			
* 4	O-ring, Outer Stem (qty 2 req) Nitrile	N90020	N90020	N90020	N90020
* 5	Bearing, Upper Adapter (qty 2 req)	102002+	102002+	102002+	POA
* 6	O-ring, Body (qty 4 req) EPDM	E70244	E70244	E70244	E70258
		FKM	V70244	V70244	V70244
8	Stem, Upper Assembly - See note 1, below				
* 10	Seat Ring - Tri Ring, Upper EPDM	102491+	102491+	102491+	102738+
		FKM	107977+	107977+	107977+
* 11	Seat Ring - Tri Ring, Vent EPDM	102490+	102490+	102490+	102737+
		FKM	107976+	107976+	107976+
* 12	Seat Ring - O-ring, Lower EPDM	E80340	E80340	E80340	E80354
		FKM	V80340	V80340	V80340
* 14a	Quad Ring, Lower EPDM	116952+	116952+	116952+	122350+
		FKM	116953+	116953+	116953+
* 15	Bearing, Lower Seal Retainer	102003+	102003+	102003+	102004+
16	Stem, Lower Assembly - See note 1, below				
17a	Seal Retainer, Quad Ring	106070+	106070+	106070+	125047+
18	Clamp (qty 2 required)	119-87	119-87	119-87	119-123
19	Spray Bushing	118210+	118210+	118210+	118210+
20a	Adapter, O-ring or Quad Ring	128538+	128538+	128538+	POA
* 21a	Quad Ring, Upper Stem (qty 2 req) EPDM	116282+	116282+	116282+	POA
		FKM	116283+	116283+	116283+
24	Stem, Actuator - See note 1, below				
* 29	O-ring, Flush EPDM	E70111	E70111	E70111	E70111
		FKM	V70111	V70111	V70111
42	Stop Ring	122357+	122357+	122357+	122357+

* Recommended Spare Parts

PL5027-CH155

*** See actuator parts lists

1. For items 8, 16, and 24, see W72RSP Mix Proof Seat Lift with External Flush Valve Stems Chart.
4. Unless otherwise noted, quantity required is 1.
6. POA = Part # on availability; N/A = not available with this design.

W73 Divert Mix Proof Seat Lift Valve

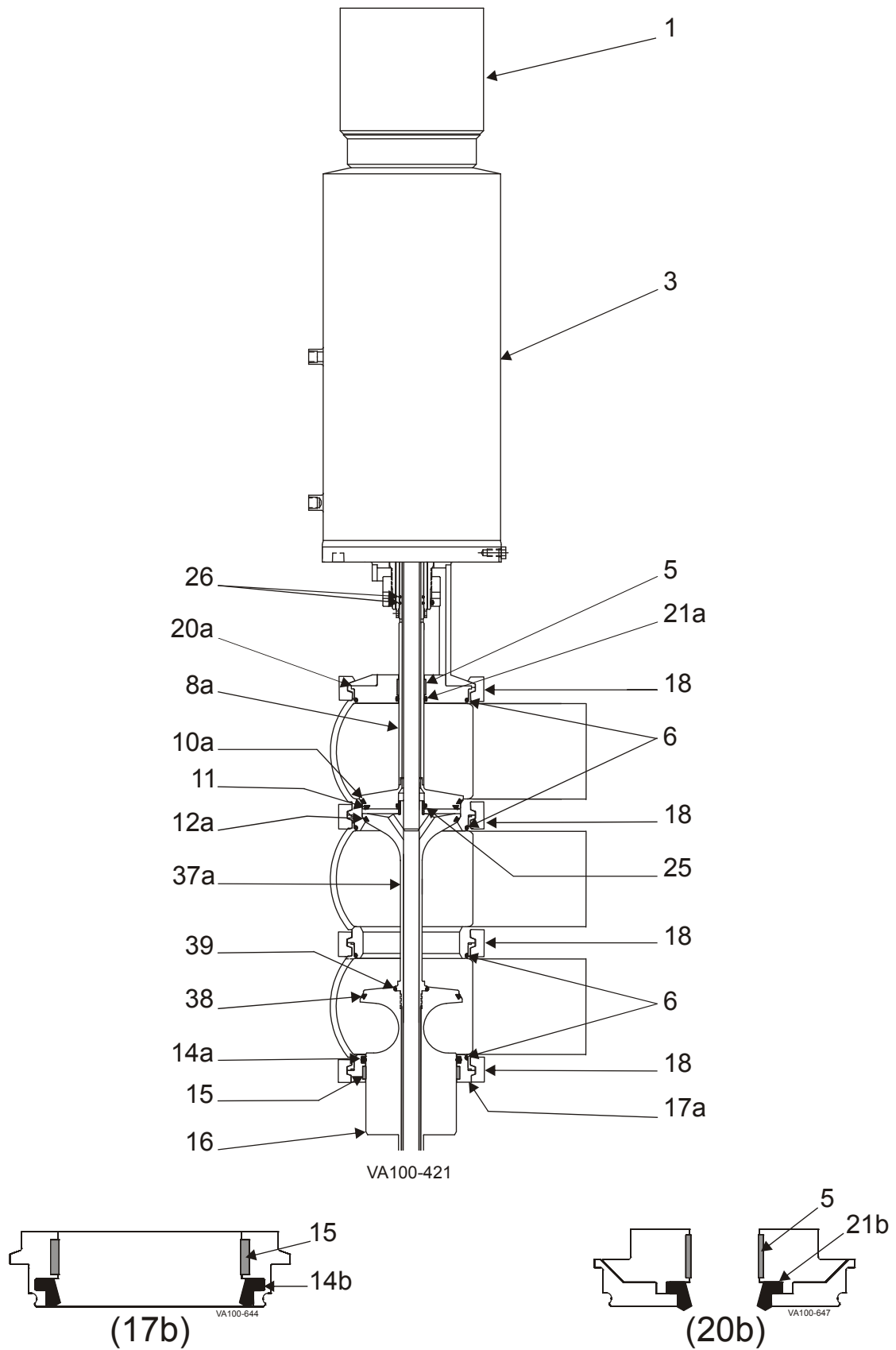

W73 Divert Mix Proof Seat Lift Valve

Item #	Part Description	1-1/2"	2"	2-1/2"	3"	4"	6"
1	Control Top	Contact Factory					
3	Actuator	***					
* 4	O-ring Nitrile	N70010	N70010	N70111	N70111	N70111	N70111
* 5	Bearing	102757+	102757+	106047+	106047+	106047+	101995+
* 6	O-ring, Body (qty 4 req)	EPDM	E70223	E70228	E70232	E70236	E70244
		FKM	V70223	V70228	V70232	V70236	V70244
8	Stem, Upper - See note 1, below						
* 10a	Seat Ring -Tri Ring, Upper	EPDM	106031+	102736+	107048+	102488+	102491+
		FKM	107990+	107980+	107982+	107974+	107977+
* 11	Seat Ring -Tri Ring, Vent	EPDM	106041+	107693+	107696+	107697+	102490+
		FKM	107992+	107984+	107987+	107988+	107976+
* 12a	Seat Ring -Tri Ring, Lower	EPDM	106036+	107693+	102487+	102489+	102492+
		FKM	107991+	107984+	107973+	107975+	107978+
* 14a	O-ring, Lower Stem	EPDM	E70322	E70327	E70331	E70335	E70342
		FKM	V70322	V70327	V70331	V70335	V70342
	Quad Ring, Lower	EPDM	122690+	35413+	117992+	117561+	116952+
		FKM	122689+	35414+	117993+	117562+	116953+
* 15	Bearing		101947+	102000+	106049+	106048+	102003+
16	Stem, Lower - See note 1, below						
17a	Seal Retainer, O-ring or Quad Ring		106066+	106067+	106068+	106069+	106070+
17b	Seal Retainer, Wiping Stem Seal		117444+	117445+	117446+	117447+	117448+
18	Clamp		119-30	119-33	119-34	119-51	119-87
20a	Adapter, O-ring or Quad Ring		111043+	111017+	111196+	111026+	111029+
20b	Adapter, Wiping Stem Seal		119467+	119468+	119469+	119470+	119471+
* 21a	O-ring, Upper Stem	EPDM	E70210	E70210	E70214	E70214	E70214
		FKM	V70210	V70210	V70214	V70214	V70214
	Quad Ring, Upper	EPDM	121300+	121300+	124163+	124163+	124163+
		FKM	124088+	124088+	121299+	121299+	121299+
* 21b	Wiping Stem Seal, Upper	EPDM	116183+	116183+	116184+	116184+	116184+
		FKM	115626+	115626+	116185+	116185+	116185+
* 25	O-ring	EPDM	E70115	E70115	E70121	E70121	E70121
		FKM	V70115	V70115	V70121	V70121	V70121
* 26	O-ring (qty 2 required)	Nitrile	N90016	N90016	N90020	N90020	N90020
37	Stem, Middle - See note 1, below						
* 38	Tri Ring, Divert Stem	EPDM	106036+	107693+	107048+	111633+	102492+
		FKM	107991+	107984+	107982+	111635+	107978+
* 39	O-ring, Divert stem	EPDM	E70210	E70215	E70217	E70217	E70217
		FKM	V70210	V70215	V70217	V70217	V70217

Notes: * Recommended Spare Parts

PL5027-CH55a

*** See actuator parts lists

1. For items 8, 16, 37, see W73 Mix Proof Seat Lift Valve Stems Chart.
4. Unless otherwise noted, quantity required is 1.
6. POA = Part # on availability; N/A = not available with this design.

W73 Divert Mix Proof Seat Lift Valve with External Flush

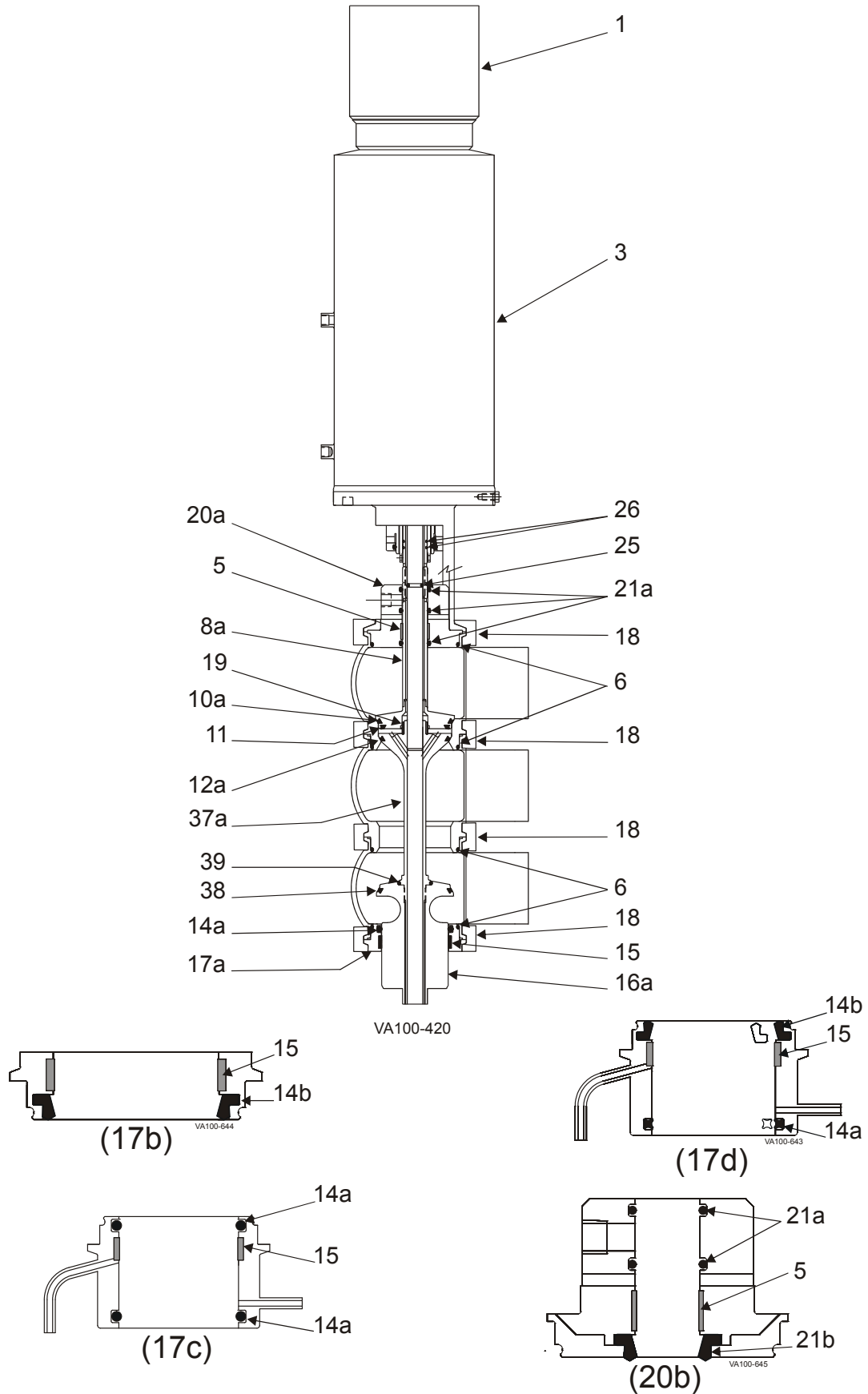

W73 Divert Mix Proof Seat Lift Valve with External Flush

Item #	Part Description	1-1/2"	2"	2-1/2"	3"	4"	6"
1	Control Top	Contact Factory					
3	Actuator	***					
* 4	O-ring Nitrile	N70010	N70010	N70111	N70111	N70111	N70111
* 5	Bearing	102757+	102757+	106047+	106047+	106047+	101995+
* 6	O-ring, Body (qty 4 req)	EPDM	E70223	E70228	E70232	E70236	E70244
		FKM	V70223	V70228	V70232	V70236	V70244
8	Stem, Upper Assembly - See note 1, below						
* 10a	Seat Ring -Tri Ring, Upper	EPDM	106031+	102736+	107048+	102488+	102491+
		FKM	107990+	107980+	107982+	107974+	107977+
* 11	Seat Ring -Tri Ring, Vent	EPDM	106041+	107693+	107696+	107697+	102490+
		FKM	107992+	107984+	107987+	107988+	107976+
* 12a	Seat Ring -Tri Ring, Lower	EPDM	106036+	107693+	102487+	102489+	102492+
		FKM	107991+	107984+	107973+	107975+	107978+
* 14a	O-ring, Lower Stem	EPDM	E70322	E70327	E70331	E70335	E70342
		FKM	V70322	V70327	V70331	V70335	V70342
	Quad Ring, Lower	EPDM	122690+	35413+	117992+	117561+	116952+
		FKM	122689+	35414+	117993+	117562+	116953+
* 14b	Wiping Stem Seal, Lower	EPDM	116186+	116188+	116190+	116195+	116199+
		FKM	116187+	116189+	116191+	116196+	116200+
* 15	Bearing		101947+	102000+	106049+	106048+	102003+
16	Stem, Lower Assembly - See note 1, below						
17a	Seal Retainer, O-ring or Quad Ring		106066+	106067+	106068+	106069+	106070+
17b	Seal Retainer, Wiping Stem Seal		117444+	117445+	117446+	117447+	117448+
17c	Seal Retainer, Lower Flush, O-ring or Quad Ring		114918+	114919+	114920+	114921+	114922+
17d	Seal Retainer, Lower Flush, Wiping Stem Seal		119050+	119035+	118226+	117559+	118253+
18	Clamp		119-30	119-33	119-34	119-51	119-87
19	Spray Bushing		106030+	106030+	107950+	107950+	107950+
20a	Adapter, O-ring or Quad Ring		106020+	106021+	106022+	106023+	106024+
20b	Adapter, Wiping Stem Seal		119482+	119483+	119484+	119485+	119486+
* 21a	O-ring, Upper Stem	EPDM	E70210	E70210	E70214	E70214	E70214
		FKM	V70210	V70210	V70214	V70214	V70214
	Quad Ring, Upper (qty 3 required)	EPDM	121300+	121300+	124163+	124163+	124163+
		FKM	124088+	124088+	121299+	121299+	121299+
* 21b	Wiping Stem Seal, Upper	EPDM	116183+	116183+	116184+	116184+	116184+
		FKM	115626+	115626+	116185+	116185+	116185+
* 25	O-ring	EPDM	E70010	E70010	E70111	E70111	E70111
		FKM	V70010	V70010	V70111	V70111	V70111
* 26	O-ring (qty 2 required)	Nitrile	N90016	N90016	N90020	N90020	N90020
37	Stem, Middle - See note 1, below						
* 38	Tri Ring, Divert Stem	EPDM	106036+	107693+	107048+	111633+	102492+
		FKM	107991+	107984+	107982+	111635+	107978+
* 39	O-ring, Divert stem	EPDM	E70210	E70215	E70217	E70217	E70217
		FKM	V70210	V70215	V70217	V70217	V70223

Notes: * Recommended Spare Parts

PL5027-CH56a

*** See actuator parts lists

- For items 8, 16, 37, see W73 Divert Mix Proof Seat Lift with External Flush Valve Stems Chart.
- Unless otherwise noted, quantity required is 1.
- POA = Part # on availability; N/A = not available with this design.

W71 Valve Stems**W71 Mix Proof Non-Seat Lift (See page 32)**

Item #	Part Description	1-1/2"	2"	2-1/2"	3"	4"	6"
8a	Stem, Upper	116615+	115788+	115663+	115648+	115793+	POA
16a	Stem, Lower Assembly ⁷	118150+	118151+	118152+	118153+	118154+	POA

PL5027-CH104a

W71 Mix Proof Non-Seat Lift with External Flush (See page 34)

Item #	Part Description	1-1/2"	2"	2-1/2"	3"	4"	6"
8a	Stem, Upper Assembly ^{8, 10}	106015+	106016+	106017+	106018+	106019+	128647+
16a	Stem, Lower Assembly ⁹	106051+	106052+	106053+	106054+	106055+	129719+
24	Stem, Actuator, NSL Flush	107790+	107756+	107949+	107949+	107949+	129703+

PL5027-CH105a

W71 Mix Proof Non-Seat Lift with Steam Adapter (See page 36)

Item #	Part Description	1-1/2"	2"	2-1/2"	3"	4"	6"
8a	Stem, Upper Assembly ⁸	130673+	126218+	POA	122284+	POA	POA
16a	Stem, Lower Assembly ⁹	114933+	114934+	114935+	114936+	114937+	POA
24	Stem, Actuator, NSL Flush	107790+	107756+	107949+	107949+	107949+	129703+

PL5027-CH130a

W71 Mix Proof Seat Lift (See page 38)

Item #	Part Description	1-1/2"	2"	2-1/2"	3"	4"	6"
8a	Stem, Upper	111042+	111014+	111052+	111022+	111049+	POA
16a	Stem, Lower Assembly ⁷	118247+	118248+	118249+	118250+	118251+	POA

PL5027-CH106a

W71 Mix Proof Seat Lift with External Flush (See page 40)

Item #	Part Description	1-1/2"	2"	2-1/2"	3"	4"	6"
8a	Stem, Upper Assembly ¹¹	119199+	119200+	119201+	119202+	119203+	POA
16a	Stem, Lower Assembly ⁹	111499+	111513+	111519+	111520+	111524+	POA

PL5027-CH107a

W71 Mix Proof Seat Lift with Steam Adapter (See page 42)

Item #	Part Description	1-1/2"	2"	2-1/2"	3"	4"	6"
8a	Stem, Upper Assembly ¹¹	POA	POA	POA	POA	POA	N/A
16a	Stem, Lower Assembly ⁹	118241+	118409+	118243+	118244+	118245+	N/A

PL5027-CH131a

Notes

5. EPDM recommended on all steam-contact seals.
6. POA = Part # on availability; N/A = not available with this design.
7. Part number includes lower stem and stem bushing, which are assembled together.
8. Part number includes upper stem and coupling sleeve, which are assembled together.
9. Part number includes lower stem and inner stem, which are assembled together.
10. A separate actuator stem (item 24) mates with item 8.
11. Part number includes upper stem, outer stem and coupling sleeve, which are assembled together.
12. Part number includes upper stem, outer stem and outer stem bushing, which are assembled together.
13. Unless otherwise noted, quantity required is 1.

PL5027-CH138

W72RS Valve Stems**W72RS Mix Proof Non-Seat Lift (See page 44)**

Item #	Part Description	1-1/2"	2"	2-1/2"	3"	4"	6"
8	Stem, Upper	119268+	118484+	119281+	118534+	119346+	POA
16	Stem, Lower Assembly ⁹	119477+	119478+	119479+	119480+	119481+	POA

PL5027-CH102

W72RS Mix Proof Non-Seat Lift with External Flush (See page 46)

Item #	Part Description	1-1/2"	2"	2-1/2"	3"	4"	6"
8	Stem, Upper Assembly ¹¹	106015+	106016+	106017+	106018+	106019+	POA
16	Stem, Lower Assembly ⁹	POA	120893+	125484+	120894+	POA	POA
24	Stem, Actuator, NSL Flush	122389+	118642+	118625+	118625+	107949+	129703+

PL5027-CH108

W72RS Mix Proof Non-Seat Lift with Steam Adapter (See page 48)

Item #	Part Description	1-1/2"	2"	2-1/2"	3"	4"	6"
8	Stem, Upper Assembly ⁷	119452+	119453+	119454+	119455+	119456+	POA
16	Stem, Lower Assembly ⁸	119462+	119463+	119464+	119465+	119466+	POA
24	Stem, Actuator, NSL Flush	122389+	118642+	118625+	118625+	107949+	129703+

PL5027-CH132

W72RS Mix Proof Seat Lift (See page 50)

Item #	Part Description	1-1/2"	2"	2-1/2"	3"	4"	6"
8	Stem, Upper	113390+	113091+	113263+	113102+	113265+	POA
16	Stem, Lower Assembly ⁹	119436+	119437+	119438+	119439+	119440+	POA

PL5027-CH121

W72RS Mix Proof Seat Lift with External Flush (See page 52)

Item #	Part Description	1-1/2"	2"	2-1/2"	3"	4"	6"
8	Stem, Upper Assembly ¹¹	119447+	119448+	119449+	119450+	119451+	POA
16	Stem, Lower Assembly ⁹	119457+	119458+	119459+	119460+	119461+	POA

PL5027-CH122

W72RS Mix Proof Seat Lift with Steam Adapter (See page 54)

Item #	Part Description	1-1/2"	2"	2-1/2"	3"	4"	6"
8	Stem, Upper Assembly ¹¹	119452+	119453+	119454+	119455+	119456+	POA
16	Stem, Lower Assembly ⁹	119462+	119463+	119464+	119465+	119466+	POA

PL5027-CH133

Notes

5. EPDM recommended on all steam-contact seals.
6. POA = Part # on availability; N/A = not available with this design.
7. Part number includes lower stem and stem bushing, which are assembled together.
8. Part number includes upper stem and coupling sleeve, which are assembled together.
9. Part number includes lower stem and inner stem, which are assembled together.
10. A separate actuator stem (item 24) mates with item 8.
11. Part number includes upper stem, outer stem and coupling sleeve, which are assembled together.
12. Part number includes upper stem, outer stem and outer stem bushing, which are assembled together.
13. Unless otherwise noted, quantity required is 1.

PL5027-CH138

W72RS Valve Stems continued on next page.

W72RS Mix Proof Seat Lift with Upper Balancer Option (See page 56)

Item #	Part Description	2"	2-1/2"	3"	4"
8	Stem, Upper	126052+	POA	126043+	126059+
16	Stem, Lower Assembly ⁹	119437+	119438+	119439+	119440+

PL5027-CH137

W72RS Mix Proof Seat Lift Tank Outlet (See page 58)

Item #	Part Description	2-1/2"	3"	4"	6"
8	Stem, Outer (Pipe Side)	126015+	125970+	126020+	POA
16	Stem, Inner (Tank Side)	125996+	125967+	126024+	POA

PL5027-CH136

W72RS Mix Proof Seat Lift Tank Outlet with External Flush (See page 60)

Item #	Part Description	2-1/2"	3"	4"	6"
8	Stem, Outer (Pipe Side)	POA	127748+	129289+	POA
16	Stem, Inner (Tank Side)	POA	127749+	129381+	POA
24	Stem, Actuator	POA	109910+	116821+	POA

PL5027-CH149

W72RSP Valve Stems

W72RSP Mix Proof Seat Lift (See page 62)

Item #	Part Description	2.5"	3"	4"	6"
8	Stem, Upper Assembly ¹¹	126880+	126880+	126880+	POA
16	Stem, Lower Assembly ⁹	129983+	129983+	129983+	POA

PL5027-CH158

W72RSP Mix Proof Seat Lift with External Flush (See page 64)

Item #	Part Description	2.5"	3"	4"	6"
8	Stem, Upper Assembly ¹¹	128536+	128536+	128536+	POA
16	Stem, Lower Assembly ⁹	129984+	129984+	129984+	POA
24	Stem, Actuator	128535+	128535+	128535+	POA

PL5027-CH157

Notes

5. EPDM recommended on all steam-contact seals.
6. POA = Part # on availability; N/A = not available with this design.
7. Part number includes lower stem and stem bushing, which are assembled together.
8. Part number includes upper stem and coupling sleeve, which are assembled together.
9. Part number includes lower stem and inner stem, which are assembled together.
10. A separate actuator stem (item 24) mates with item 8.
11. Part number includes upper stem, outer stem and coupling sleeve, which are assembled together.
12. Part number includes upper stem, outer stem and outer stem bushing, which are assembled together.
13. Unless otherwise noted, quantity required is 1.

PL5027-CH138

W73 Valve Stems

W73 Divert Mix Proof Seat Lift (See page 66)

Item #	Part Description	1-1/2"	2"	2-1/2"	3"	4"	6"
8	Stem, Upper	111042+	111014+	111052+	111022+	111049+	POA
16a	Stem, Lower	116686+	115911+	116388+	114506+	115651+	128650+
37a	Stem, Middle, Tri-Ring	POA	POA	POA	POA	POA	POA

PL5027-CH124a

W73 Divert Mix Proof Seat Lift with External Flush (See page 68)

Item #	Part Description	1-1/2"	2"	2-1/2"	3"	4"	6"
8	Stem, Upper Assembly ¹²	119200+	119201+	119202+	119203+	119204+	128647+
16a	Stem, Lower	116686+	115911+	116388+	114506+	115651+	128650+
16c	Stem, Lower Flush	POA	POA	POA	POA	POA	POA
37a	Stem, Middle, Tri-Ring	POA	POA	POA	POA	POA	POA

PL5027-CH126a

Notes

5. EPDM recommended on all steam-contact seals.
6. POA = Part # on availability; N/A = not available with this design.
7. Part number includes lower stem and stem bushing, which are assembled together.
8. Part number includes upper stem and coupling sleeve, which are assembled together.
9. Part number includes lower stem and inner stem, which are assembled together.
10. A separate actuator stem (item 24) mates with item 8.
11. Part number includes upper stem, outer stem and coupling sleeve, which are assembled together.
12. Part number includes upper stem, outer stem and outer stem bushing, which are assembled together.
13. Unless otherwise noted, quantity required is 1.

PL5027-CH138

Mix Proof Valve Bodies for W71, W72RS, W72RSP, and W73 Valves

W71, W72RS, W72RSP One Piece Bodies

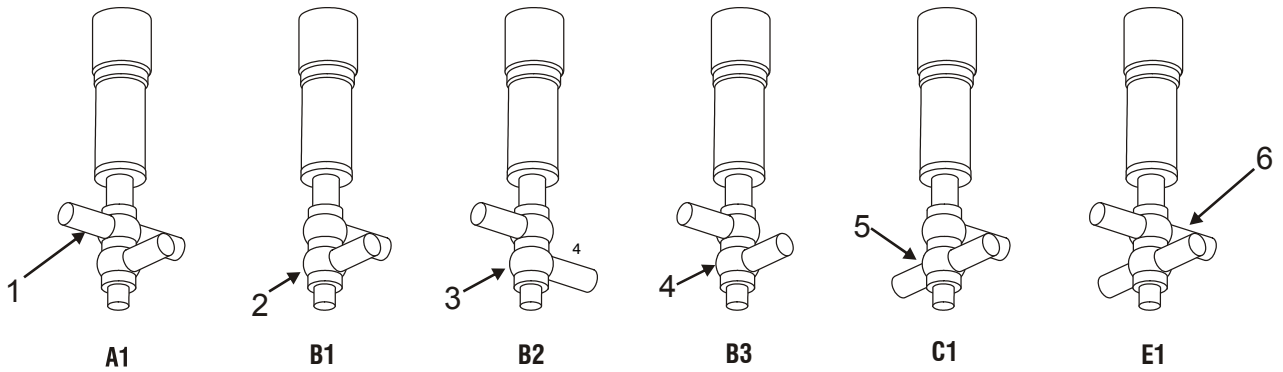

VA100-436b

W71 & W72RS Two Piece Clamped Bodies *

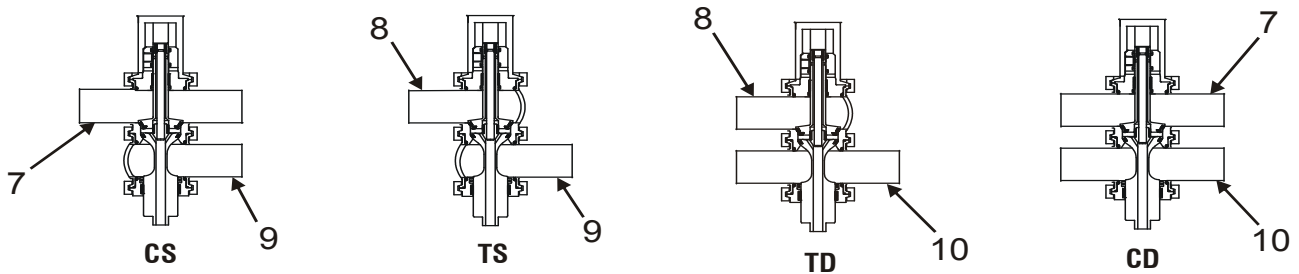

VA100-436c

W72RS Tank Outlet Valve Two Piece Clamped Bodies *

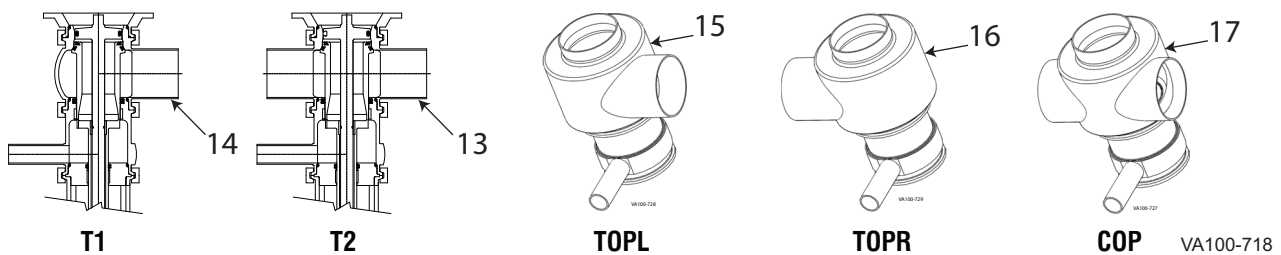

VA100-718

W73-Divert Three Piece Clamped Bodies *

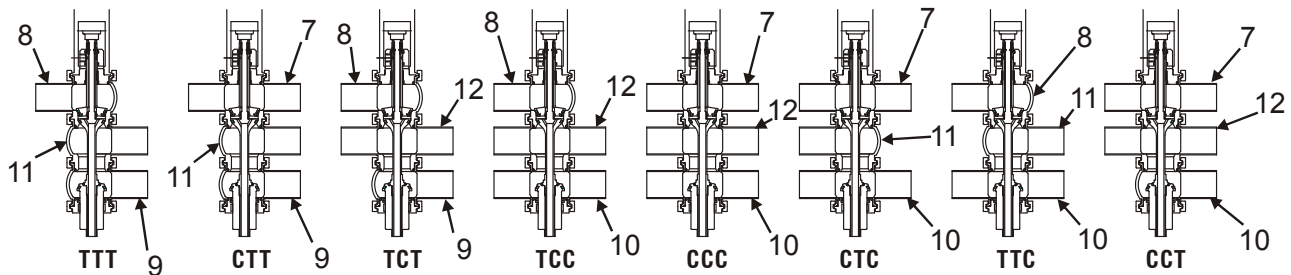

VA100-436d

* Clamped bodies allow for ports to be rotated in any direction.

Mix Proof Valve Bodies for W71, W72RS, W72RSP, and W73 Valves

Item #	Part Description	1-1/2"	2"	2-1/2"	3"	4"
W71 One Piece Body						
1	Buttweld - A1	107758+	107803+	107898+	107922+	107945+
2	Buttweld - B1	107760+	107805+	107900+	107924+	107947+
3	Buttweld - B2	114652+	112515+	114458+	113726+	114579+
4	Buttweld - B3	107761+	107806+	107901+	107925+	107948+
5	Buttweld - C1	107759+	107804+	107899+	107923+	107946+
6	Buttweld - E1	107757+	107802+	107897+	107921+	107944+
W72RS One Piece Body						
1	Buttweld - A1	113274+	113082+	113268+	113076+	113254+
2	Buttweld - B1	113276+	113084+	113270+	113078+	113256+
3	Buttweld - B2	113277+	113085+	113271+	114835+	113257+
4	Buttweld - B3	113278+	113086+	113272+	113079+	113258+
5	Buttweld - C1	113275+	113083+	113269+	113077+	113255+
6	Buttweld - E1	113273+	113081+	113267+	113075+	113253+
W72RSP One Piece Body						
1	Buttweld - A1	N/A	N/A	126926+	126916+	113254+
2	Buttweld - B1	N/A	N/A	126928+	126918+	113256+
3	Buttweld - B2	N/A	N/A	126929+	126919+	113257+
4	Buttweld - B3	N/A	N/A	126930+	126920+	113258+
5	Buttweld - C1	N/A	N/A	126927+	126917+	113255+
6	Buttweld - E1	N/A	N/A	126925+	126915+	113253+
W71/W73						
7	Upper Cross, S-Line	108560+	108565+	108570+	108575+	108580+
8	Upper Tee, S-Line	108530+	108535+	108540+	108545+	108550+
W72RS						
7	Upper Cross, S-Line	119488+	119489+	119490+	119491+	119492+
8	Upper Tee, S-Line	119493+	119494+	119495+	119496+	119497+
W72RS Tank Outlet						
13	Upper Cross, T2	N/A	N/A	123784+	119026+	123786+
14	Upper Tee, T1	N/A	N/A	123783+	119025+	123785+
15	Tee, Offset Port - Right (TOPR)	N/A	N/A	POA	POA	POA
16	Tee, Offset Port - Left (TOPL)	N/A	N/A	POA	POA	POA
17	Cross, Offset Port (COP)	N/A	N/A	POA	POA	POA
W71/W72RS/W73						
9	Lower Tee, S-Line	108590+	108595+	108600+	108605+	108610+
10	Lower Cross, S-Line	108620+	108625+	108630+	108635+	108640+
W73						
11	Middle Tee, S-Line	118262+	118267+	118272+	118277+	118282+
12	Middle Cross, S-Line	118292+	118297+	118302+	118307+	118312+

PL5027-CH57

W71/W73 Non-Seat Lift Actuator

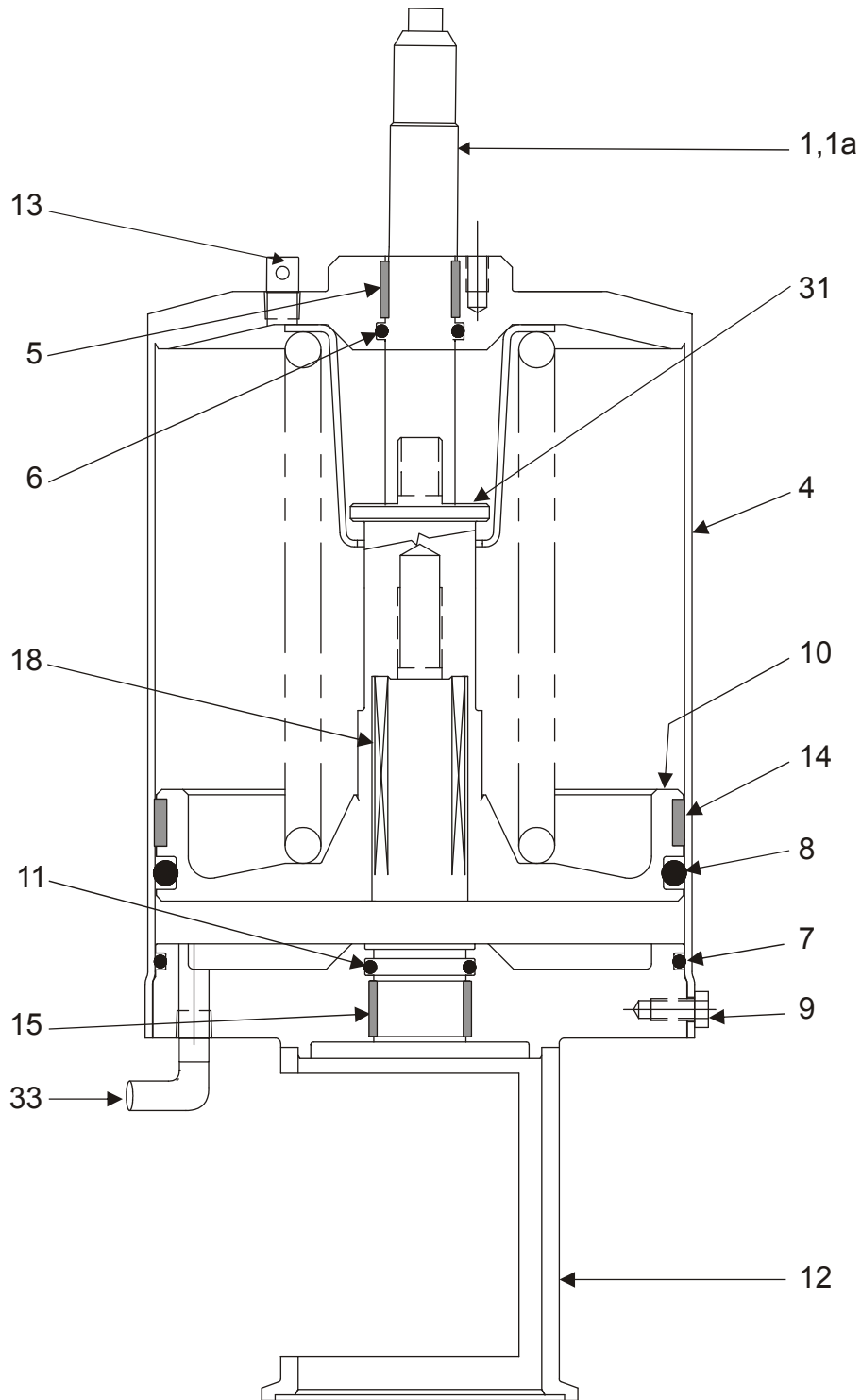

VA100-430

W71/W73 Non-Seat Lift Actuator

Item #	Part Description	4" Diameter ¹	6" Diameter ¹	8" Diameter ¹
1	Indicator Stem - Visual	106050+	107951+	POA
1a	Indicator Stem - Control Top	106003+	106004+	110800+
4	Cylinder	106006+	106007+	128394+
* 5	Bearing, Indicator Stem	102757+	102757+	102757+
* 6	O-ring, Indicator Stem Nitrile	N70210	N70210	N70210
* 7	O-ring, Outer Yoke Nitrile	N70240	N70255	N70367
* 8	O-ring, Piston Nitrile	N70342	N70433	N70443
9	Cap Screw, 1/4-20 x .375" lg.	30-68 (qty 4 req)	30-68 (qty 8 req)	30-361 (qty 12 req)
10	Piston & Spring Assembly	106009+	106010+	129822+
* 11	O-ring, Yoke Nitrile	N70210	N70214	N70214
12	Yoke	1-1/2" Valve	106119+	--
		2" Valve	107764+	--
		2 1/2" Valve	--	106120+
		3" Valve	--	106121+
		4" Valve	--	106118+
		6" Valve	--	--
13	Vent Plug (see note 2)	3023957+	3023957+	3023957+
* 14	Bearing, Piston	101995+	102052+	100256+
* 15	Bearing, Yoke	102757+	106047+	106047+
18	Spring, Upper Stem	101946+	5901106+	5901106+
31	Washer (see note 3)	43-55	--	--
33	Elbow swivel 90°	78-157	78-157	78-157

Complete Actuator Assemblies

Part Description			4" Diameter ¹	6" Diameter ¹	8" Diameter ¹
Air-to-Raise	Visual Indicator Stem	1-1/2"	ACT00188	--	--
		2"	ACT00122	--	--
		2-1/2"	--	ACT00279	--
		3"	--	ACT00280	--
		4"	--	ACT00281	--
		6"	--	--	POA

Notes:

PL5027-CH58

* **Recommended Spare Parts**

1. 4-inch diameter actuator for 1-1/2inch and 2-inch valves; 6-inch diameter actuator for 2-1/2 inch and 4-inch valves; 8" diameter for 6 inch valves.
2. Only required for valves without control top.
3. Item 31 is required on 1-1/2" valves only.
4. Unless otherwise noted, quantity required is 1.

W71/W73 Seat Lift Actuator

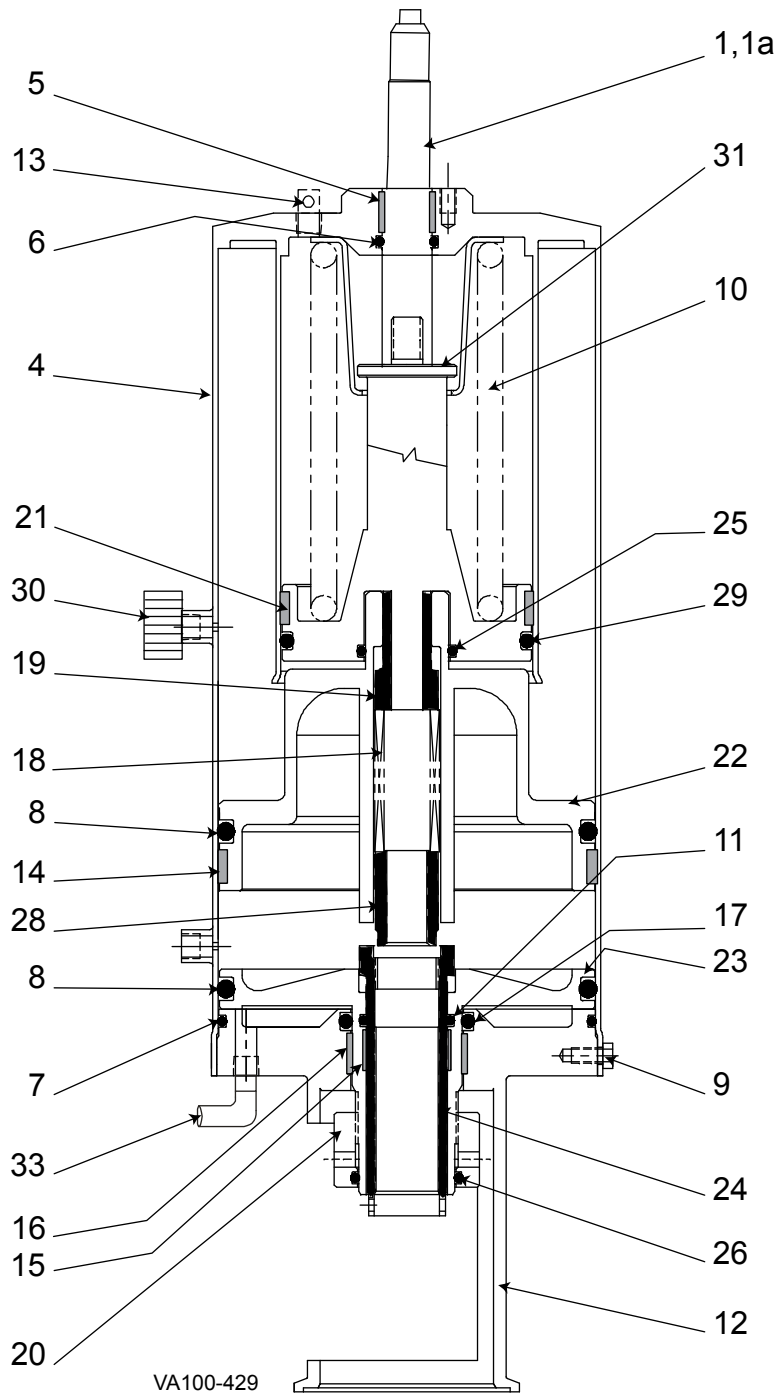

W71/W73 Seat Lift Actuator

Item #	Part Description	4" Diameter ¹	6" Diameter ¹	8" Diameter ¹
1	Indicator Stem - Visual	106050+	107951+	POA
1a	Indicator Stem - Control Top	106003+	106004+	110800+
4	Cylinder	111506+	111491+	123974+
* 5	Bearing, Indicator Stem	102757+	102757+	102757+
* 6	O-ring, Indicator Stem Nitrile	N70210	N70210	N70210
* 7	O-ring, Outer Yoke Nitrile	N70240	N70255	N70367
* 8	O-ring, Upper Seat Piston (qty 2 req) Nitrile	N70342	N70433	N70443
9	Cap Screw, 1/4-20 x .375" lg.	30-68 (qty 4 req)	30-68 (qty 8 req)	30-361 (qty 12 req)
10	Lower Seat Piston & Spring Assembly	113661+	113660+	129823+
* 11	O-ring, Adjustment Sleeve (qty 2 req) Nitrile	N70214	N70219	N70219
12	Yoke	1-1/2" Valve 109823+	--	--
		2" Valve 109940+	--	--
		2 1/2" Valve --	109928+	--
		3" Valve --	109934+	--
		4" Valve --	109905+	--
		6" Valve --	--	128655+
13	Vent Plug (see note 2)	3023957+	3023957+	3023957+
* 14	Bearing, Main Piston	101995+	102052+	100256+
* 15	Bearing, Adjusting Sleeve	106047+	109919+	109919+
* 16	Bearing, Lifting piston	109820+	109920+	109920+
* 17	O-ring, Inner Yoke Nitrile	N70222	N70328	N70328
18	Spring, Upper Stem	101946+	5901106+	5901106+
19	Stop, Lifter	109817+	109913+	123998+
20	Adjusting Nut, Upper Seat Lift	109822+	109918+	122345+
* 21	Bearing, Lower seat piston	111044+	101995+	102052+
22	Main Piston	111510+	111486+	123979+
23	Upper Seat Lift Piston	111507+	111489+	124555+
24	Adjusting Sleeve, Lower Seat Clean	109821+	109912+	126834+
* 25	O-ring, Inner Lower Seat Piston Nitrile	N70216	N70219	N70219
* 26	O-ring, Adjusting Nut Nitrile	N80026	N80222	N80222
28	Bushing	112427+	112517+	112517+
* 29	O-ring, Outer Lower Seat Piston Nitrile	N70335	N70342	N70433
30	Quick Exhaust (avail. upon request)	114680+	114680+	114680+
31	Washer (see note 3)	43-55	--	--
33	Elbow swivel 90°	78-157	78-157	78-157

Complete Actuator Assemblies

Part Description			4" Diameter ¹	6" Diameter ¹	8" Diameter ¹
Air-to-Raise	Visual Indicator Stem	1-1/2"	ACT00282	--	--
		2"	ACT00283	--	--
		2-1/2"	--	ACT00284	--
		3"	--	ACT00285	--
		4"	--	ACT00286	--
		6"	--	--	POA

Notes:

PL5027-CH60

* Recommended Spare Parts

- 4-inch diameter actuator for 1-1/2 inch and 2-inch valves; 6-inch diameter actuator for 2-1/2 inch and 4-inch valves; 8" diameter for 6 inch valves.
- Only required for valves without control top.
- Item 31 is required on 1-1/2" valves only.
- Unless otherwise noted, quantity required is 1.

W72RS Non Seat Lift Actuator

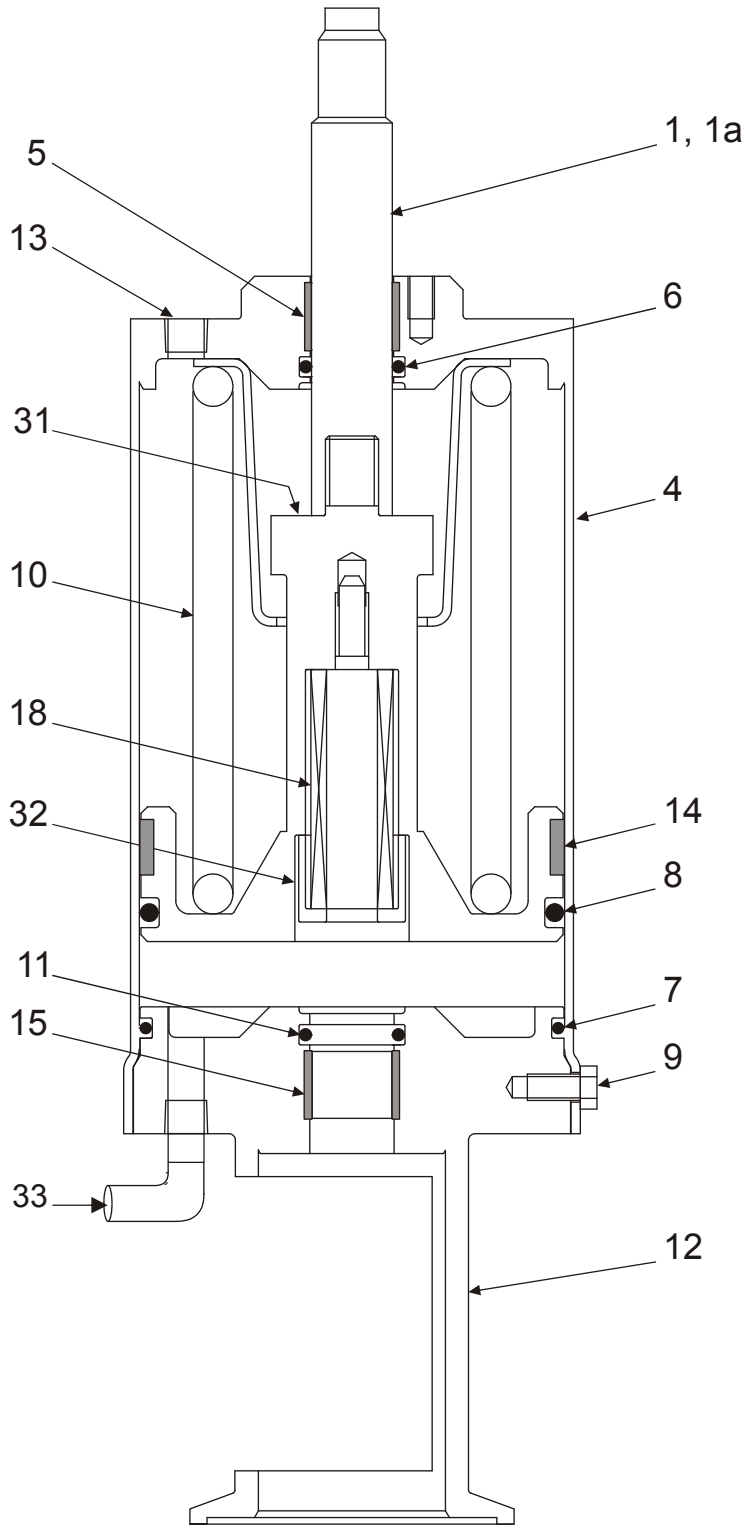

VA100-488

W72RS Non Seat Lift Actuator

Item #	Part Description	4" Diameter ¹	6" Diameter ¹	8" Diameter ¹	
1	Indicator Stem - Visual	106050+	107951+	POA	
1a	Indicator Stem - Control Top	106003+	106004+	POA	
4	Cylinder	106006+	106007+	128394+	
* 5	Bearing, Indicator Stem	102757+	102757+	102757+	
* 6	O-ring, Indicator Stem Nitrile	N70210	N70210	N70210	
* 7	O-ring, Cylinder Nitrile	N70240	N70255	N70367	
* 8	O-ring, Piston Nitrile	N70342	N70433	N70443	
9	Cap Screw, 1/4-20 x .375" lg.	30-68 (4 req)	30-68 (8 req)	30-361 (12 req)	
10	Piston & Spring Assembly	118461+	118530+	POA	
* 11	O-ring, Yoke Nitrile	N70210	N70214	N70214	
12	Yoke	1-1/2"	106119+	--	
		2"	107764+	--	
		2-1/2"	--	106120+	--
		3"	--	106121+	--
		4"	--	106118+	--
		6"	--	--	128396+
13	Vent Plug (see note 2)	3023957+	3023957+	3023957	
* 14	Bearing, Piston	101995	102052	100256+	
* 15	Bearing, Yoke	102757+	106047+	106047+	
18	Spring, Upper Stem	101946	5901106	5901106+	
31	Washer (see note 3)	43-55	--	--	
32	Spring Guide	118459	118529	POA	
33	Elbow swivel 90°	78-157	78-157	78-157	

Complete Actuator Assemblies

Part Description	For Valve Size	4" Diameter ¹	6" Diameter ¹	8" Diameter ¹
Air-to-Raise Visual Indicator Stem	1-1/2"	ACT00342	--	--
	2"	ACT00343	--	--
	2-1/2"	--	ACT00344	--
	3"	--	ACT00345	--
	4"	--	ACT00346	--
	6"	--	--	POA
Control Top Indicator Stem	1-1/2"	ACT00352	--	--
	2"	ACT00353	--	--
	2-1/2"	--	ACT00354	ACT00354
	3"	--	ACT00355	ACT00355
	4"	--	ACT00356	ACT00356
	6"	--	--	POA

Notes:

PL5027-CH62

* **Recommended Spare Parts**

1. 4-inch diameter actuator for 1-1/2inch and 2-inch valves, 6-inch diameter actuator for 2-1/2 inch through 4-inch valves, 8-inch diameter actuator for 6-inch valves.
2. Only required for valves without control top
3. Item 31 is required on 1-1/2" valves only.

W72RS/W72RSP Seat Lift Actuator

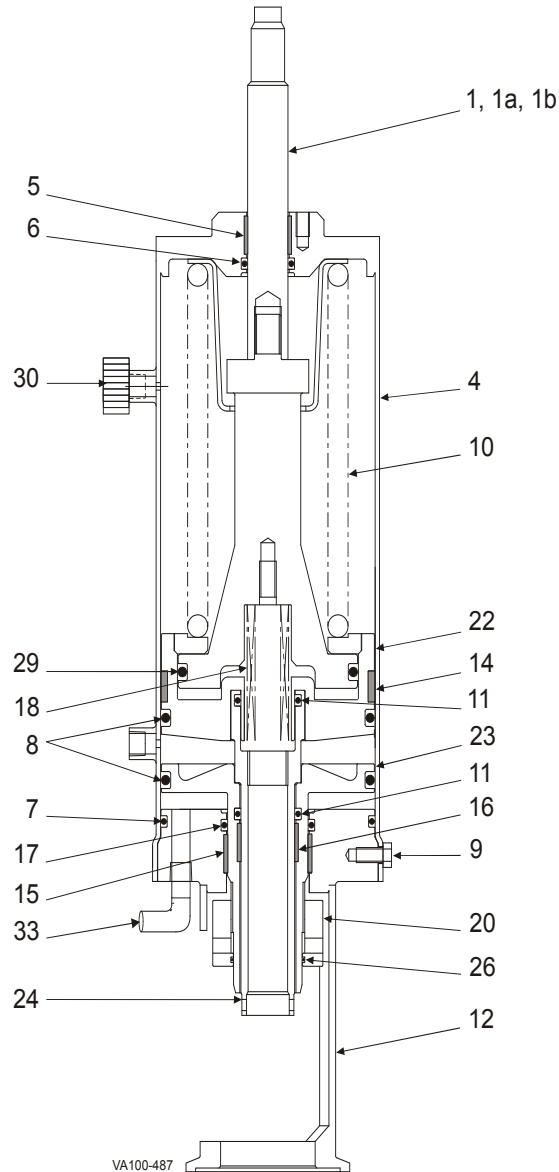

W72RS/W72RSP Complete Actuator Assemblies (see note 3)

Part Description	For Valve Size	W72RS			W72RSP
		4" Dia. ¹	6" Dia. ¹	8" Dia. ¹	
Air-to-Raise Visual Indicator Stem	1-1/2"	ACT00337	--	--	POA
	2"	ACT00338	--	--	
	2-1/2"	--	ACT00339	--	
	3"	--	ACT00340	--	
	4"	--	ACT00341	--	
	6"	--	--	POA	
Control Top Indicator Stem	1-1/2"	ACT00347	--	--	POA
	2"	ACT00348	--	--	
	2-1/2"	--	ACT00349	--	
	3"	--	ACT00350	--	
	4"	--	ACT00351	--	
Control Top Indicator Stem - Tank Outlet Valve	2-1/2 & 3"	--	126096+	--	--
	4"	--	126097+	--	--

PL5027-64a

W72RS/W72RSP Seat Lift Actuator

Item #	Part Description	W72RS			W72RSP
		4" Diameter ¹	6" Diameter ¹	8" Diameter ¹	
1	Indicator Stem - Visual	106050+	107951+	POA	POA
1a	Indicator Stem - Control Top	106003+	106004+	POA	128787+
1b	Indicator Stem - used with yoke switch	--	--	--	128787+
4	Cylinder	113099+	113112+	POA	126871+
* 5	Bearing, Indicator Stem	102757+	102757+	102757+	102757+
* 6	O-ring, Indicator Stem Nitrile	N70210	N70210	N70210	N70210
* 7	O-ring, Cylinder Nitrile	N70240	N70255	N70367	N70255
* 8	O-ring, Upper Seat Piston (qty 2 req) Nitrile	N70342	N70433	N70443	N70433
9	Cap Screw, 1/4-20 x .375" lg.	30-68 (4 req)	30-68 (8 req)	30-68 (12 req)	30-68 (8 req)
10	Lower Seat Piston & Spring Assembly	1-1/2"	113680+	--	POA
		2"	113679+	--	
		2-1/2" - 4"	--	113678+	
		6"	--	--	
		2-1/2" - 4" Tank Outlet	--	129868+	
* 11	O-ring, Adjusting Sleeve (qty 2 req) Nitrile	N70214	N70219	N70219	N70219
12	Yoke	1-1/2"	109823+	--	119591+
		2"	109940+	--	
		2-1/2"; 2-1/2" - 3" Tank Outlet	--	109928+	
		3"; 4" Tank Outlet	--	109934+	
		4"	--	109905+	
		6"	--	--	
12a	Yoke with 3rd. prox switch (not shown)	See Note 3	See Note 3	See Note 3	128532+
13	Vent Plug (not shown)	3023957+	3023957+	3023957+	3023957+
* 14	Bearing, Main Piston (See note 5)	101995+	102052+	100256+	102052+
* 15	Bearing, Adjusting Sleeve	106047+	109919+	109919+	109919+
* 16	Bearing, Lifting Piston	109820+	109920+	109920+	109920+
* 17	O-ring, Inner Yoke Nitrile	N70222	N70328	N70328	N70328
18	Spring, Upper Stem	101946+	5901106+	5901106+	5901106+
20	Adjusting Nut, Upper Seat Lift	109822+	109918+	122345+	122345+
22	Main Piston	117215+	116472+	POA	116472+
	Main Piston, Tank Outlet Valve	--	116472A	--	--
23	Upper Seat Piston	111507+	111489+	124555+	124543+
24	Adjusting Sleeve, Lower Seat Clean	117439+	116469+	POA	116469+
* 26	O-ring, Adjusting Nut Nitrile	N80026	N90222	N90222	N90222
* 29	O-ring, Outer Lower Seat Piston Nitrile	N70337	N70427	N70433	N70427
30	Quick Exhaust (avail. upon request)	114680+	114680+	114680+	114680+
33	Elbow swivel 90°	78-157	78-157	78-157	78-157

Notes:

PL5027-CH64

* **Recommended Spare Parts**

1. For W72RS, 4-inch diameter actuator for 1-1/2 inch and 2-inch valves; 6-inch diameter actuator for 2-1/2 inch through 4-inch valves; 8-inch diameter actuator for 6-inch valves. (Does not apply to W72RSP Actuator.)
2. Only required for valves without control top
3. For yokes with 3rd prox. switch, please contact factory.
4. Unless otherwise noted, quantity required is 1.
5. Quantity 2 on Tank Outlet Valve only.

Installation Tools

Item	Used with Valve Model
Tri Ring Tool (Figure 31)	W71 / W72RS / W73
4" Actuator Rebuild Insertion Sleeve (Figure 32)	W71 / W73
Seal Insertion Collar Tool (Figure 33)	W72RS / W72RSP
Mix Proof Valve Lifter (Figure 34)	All Mix Proof Valves

Figure 31 - Tri Ring Tool (for W71 / W73 and W72RS Valves)

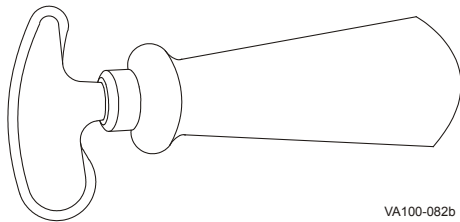

VA100-082b

Tri Ring Tool	102797+
	PL5027-CH85

Figure 32 - 4" Actuator Rebuild Insertion Sleeve (for W71 / W73 Valves)

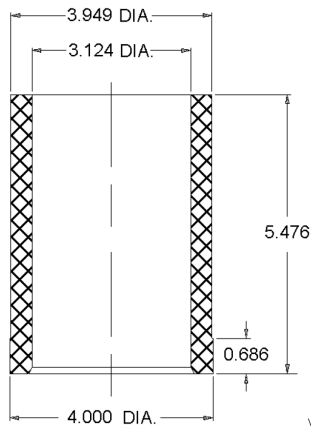

VA100-641

NOTE: The insertion sleeve is available from WCB using the part number below, or it can be created by most machine shops using #6 nylon round stock. See insertion sleeve dimensions shown at left.

- Material is #6 nylon round stock.
- Bevel the inside and outside end corners.

4" Actuator Rebuild Insertion Sleeve	111840+
	PL5027-CH90

Figure 33 - Seal Insertion Collar Tool (for W72RS and W72RSP Valves)

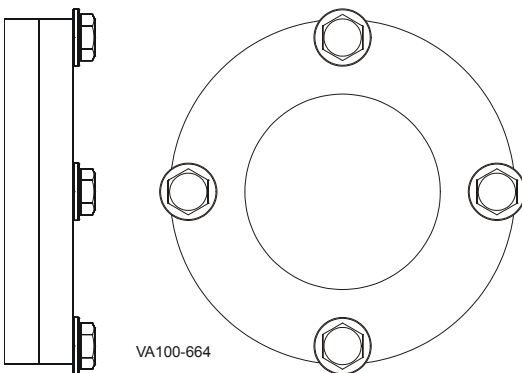

VA100-664

Valve Size	1-1/2"	2"	2-1/2"
Part No.	120048+	120049+	120051+

Valve Size	3"	4" *	6"
Part No.	120053+	120055+	120057+

PL5027-CH67

* W72RSP Valves only require the 4" tool.

Figure 34 - Mix Proof Valve Lifter

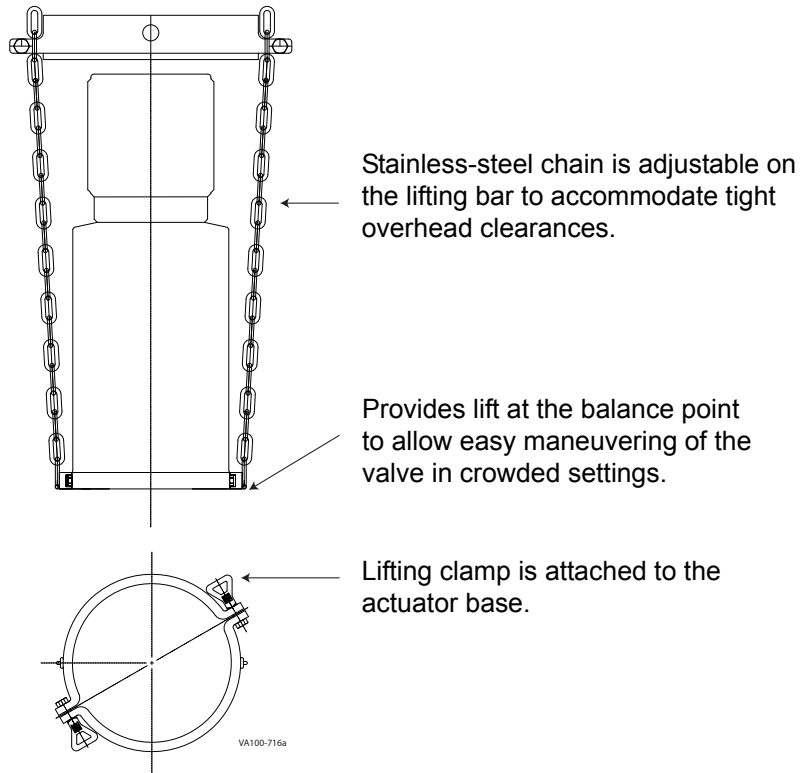

Actuator Dia.	Valve Model, Size	Part No.
4" Actuator:	1.5" & 2" O.D. W71 / W73 / W72RS / W75	127037+
6" Actuator:	2.5" through 4" O.D. W71 / W73 / W72RS / W72RSP / W75	127036+
8" Actuator:	6" O.D. W71 / W73 / W72RS / W75	127034+

PL5027-CH156A

Troubleshooting

PROBLEM	POSSIBLE CAUSE	SUGGESTED ACTION
Leakage		
Leakage from vent/drain with valve closed.	Upper or lower seat ring failure.	Remove valve. Replace seat rings.
	Debris trapped in upper seat or lower seat.	Inspect/change cleaning procedure to correct.
	Upper or lower seat not closed.	Inspect inner and outer stems for galling and burrs on adapter. Check actuator function.
	Upper or lower seat clean activated.	Check control sequence.
Leakage from vent/drain with valve open.	Tri-ring on bottom of top seat failed.	Replace seal. Inspect inner and outer stems for galling and burrs.
	Small spring not holding upper stem in place.	Check and replace small spring and stems in actuator.
Leakage around yoke.	Internal adapter o-ring failure.	Replace o-ring.
	External adapter o-ring failure.	Replace o-ring.
Leakage through outer stem.	Inner stem o-ring failure.	Replace o-ring.
Operation		
Valve fails to open.	Air pressure too low.	Set air pressure to 72 psi (5 bar) minimum.
	Control failure.	Check control sequence. Check control wiring and power source.
	Controls failed.	Check control sequence. Check control wiring and power source.
Upper seat fails to lift during seat lift.	Lifting piston not adjusted correctly.	Adjust adjusting sleeve. See "Seat Cleaning Adjustment" on page 22.
Lower seat fails to lift during seat lift.	Adjusting sleeve not adjusted correctly.	Adjust adjusting sleeve. See "Seat Cleaning Adjustment" on page 22.
Actuator moves when valve opened.	Clamp loose.	Tighten clamp with valve open.
Electrical		
No valve closed or open indication.	Lower switch not adjusted properly.	Adjust switch. See control module publications 95-03083 (2-piece) or 95-03077 (3-Piece (obsoleted)).
No valve open signal.	Upper switch not adjusted.	Adjust switch. See control module publications 95-03083 (2-piece) or 95-03077 (3-Piece (obsoleted)).
Moisture in switch housing.	Missing and/or damaged gaskets.	Replace gaskets.

W-Series Mix Proof Valves

W71, W72RS, W72RSP, W73
(IN O.D. TUBING SIZES)



SPX FLOW TECHNOLOGY

611 Sugar Creek Road

Delavan, WI 53115

P: (262) 728-1900 or (800) 252-5200

F: (262) 728-4904 or (800) 252-5012

E: wcb@spx.com

SPX reserves the right to incorporate our latest design and material changes without notice or obligation.

Design features, materials of construction and dimensional data, as described in this bulletin, are provided for your information only and should not be relied upon unless confirmed in writing.

Please contact your local sales representative for product availability in your region. For more information visit www.spx.com.

The green ">" is a trademark of SPX Corporation, Inc.

ISSUED: 10/2012

COPYRIGHT © 2012 SPX Corporation