

Save Energy Costs in Oil & Gas Processes





About APV

SPX provides advanced APV heat transfer solutions for cooling, heating, condensing and evaporation of process fluids - designed to solve heat transfer process challenges in a vast array of industries. They are designed to meet demanding process conditions and to optimize the utilisation of energy. APV heat transfer solutions have proven reliable and highly efficient helping customers worldwide to run their processes safely and economically. Since APV invented the plate heat exchanger in 1923 we have been pioneering applicable technology in pressing, shaping, welding, sealing and testing steel. Dedicated and specialized SPX staff around the world is committed to design and provide efficient and durable heat transfer solutions to help customers optimize energy utilization and minimize downtime for improved profitability.

About SPX

Based in Charlotte, North Carolina, SPX Corporation (NYSE: SPW) is a global Fortune 500 multi-industry manufacturing leader. The company's highly-specialised, engineered products and technologies serve customers in three primary strategic growth markets: infrastructure, process solutions, and diagnostic systems. Many of SPX's innovative solutions are playing a role in helping to meet rising global demand for electricity, processed foods and beverages and vehicle services, particularly in emerging markets. The company's products include food processing systems for the food and beverage industry, power transformers for utility companies, cooling systems for power plants; and diagnostic tools and equipment for the automotive industry. For more information, please visit www.spx.com.

Efficient Heat Recovery – higher heat recovery means lower energy costs

Energy consumption accounts for a significant part of Oil & Gas production costs. Minimising energy consumption through more efficient process heat recovery is critical to profitability in the face of increasing energy costs. Increasing process heat recovery efficiency delivers immediate and significant cost savings that translate directly to the bottom line.

SPX provides advanced APV heat transfer solutions for oil and gas production in both onshore and offshore locations. Lightweight and highly efficient heat transfer surfaces combine with robust and compact designs developed by APV engineering specialists to deliver reliable performance over many years, meeting the demands of the Oil & Gas industries for maximum heat recovery in demanding process conditions.

APV heat transfer solutions outperform corresponding traditional shell-and-tube technology in low- to medium-pressure heat transfer applications, playing an important role in applications ranging from cooling and heating to condensing and evaporation of process fluids:

- Crude oil stabilisation
- Gas dehydration
- Gas sweetening
- Regasification
- Utility cooling

The best choice for a given application depends on many factors and considerations. APV heat transfer specialists assist customers all over the world in selecting the solutions that will deliver the best performance and ROI over a long service life in their particular applications and process conditions.

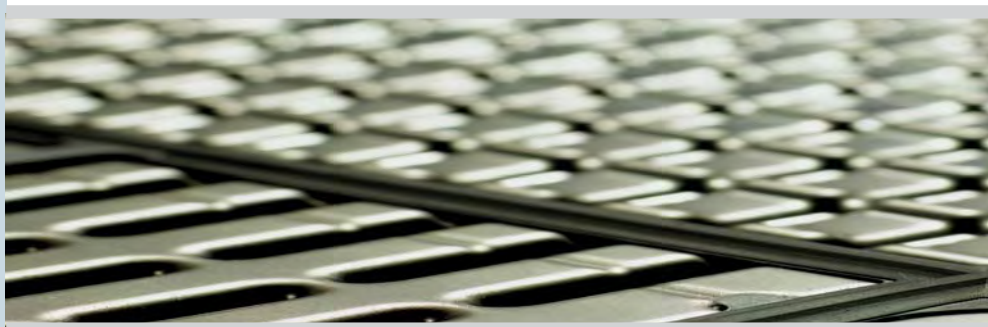



Typical Product Applications

Efficient Heat Transfer Solutions – energising performance and ROI

APV heat transfer solutions for the Oil & Gas industries are based on a complete range of plate-type heat exchanger technologies including gasketed, semi-welded and welded plate heat exchangers. These range from high-capacity, heavy-duty units to small, compact designs, and are available either as standard solutions or as customised units based on ground-breaking designs and various materials.

Superior performance in less space

Every additional degree of temperature that is recovered in the plate heat exchanger helps to reduce energy input and operating costs.

Containing more heat transfer area per volume and requiring less installed heat transfer area due to higher thermal efficiency (k-value), APV plate heat exchangers are more efficient than conventional designs. Advanced engineering and design mean higher performance into a footprint up to ten times smaller than traditional shell and tube heat exchangers. The smaller footprint means less extensive load-bearing foundations, faster installation at lower cost, and lower overall CAPEX.

Longer run times, lower maintenance costs

Designed for reduced fouling compared with in particular shell and tube technology APV plate heat exchangers have longer run times and require less service and maintenance. They provide easy inspection and maintenance access and can be cleaned using CIP-cleaning, mechanical cleaning or high-pressure cleaners.

Shorter payback time and ROI

Lower CAPEX combined with longer run times and higher thermal transfer efficiency make APV plate heat exchangers the obvious choice for Oil & Gas companies looking for bigger savings, shorter payback times and higher ROI over a longer service life.

Crude oil stabilization

Crude oil (pre-) heating and cooling
Cooling of produced water
Closed loop cooling/heating
Gas cooling and condensing



Gas dehydration

Lean/Rich TEG interchanger
Lean TEG cooler
Condenser



Gas sweetening

Amine coolers
Lean/rich amine interchangers
Sour gas coolers
Amine re-boilers
Acid condensers
Sour water coolers



Regasification

LNG preheaters
LNG evaporators



Utility cooling

Central coolers
Sea/fresh water coolers





Efficient Energy Saving in Oil and Gas Processes

– complete range for low- to medium pressure applications

Crude Oil Stabilization

Raw crude oil contains water and gases that need to be removed before the crude oil can be further processed. Gasketed and welded plate heat exchangers are typically used in this stabilisation process.

APV gasketed plate heat exchangers are used as wet crude-dry crude exchangers with an efficiency that ensures the highest possible recovery of heat from the hot-dry-crude side. APV Hybrid welded plate heat exchangers are used in higher temperature applications in which welded plate technology is required.

Applications include:

- Crude oil (pre-) heating and cooling
- Cooling of produced water
- Closed loop cooling/heating
- Gas cooling and condensing

APV plate heat exchangers are designed for the particular challenges of crude oil including high viscosities, severe fouling tendency, presence of corrosive components, and vapour breakout during the heating process.

Key product features that ensure high heat transfer performance in crude oil applications include:

- Efficient flow distribution system preventing mal-distribution
- Plate geometry promoting low pressure drop at high efficiency
- Easy-to-clean, low fouling rate plate patterns
- Corrosion-resistant materials
- Design construction preventing vapour trapping and ensuring optimal heat transfer

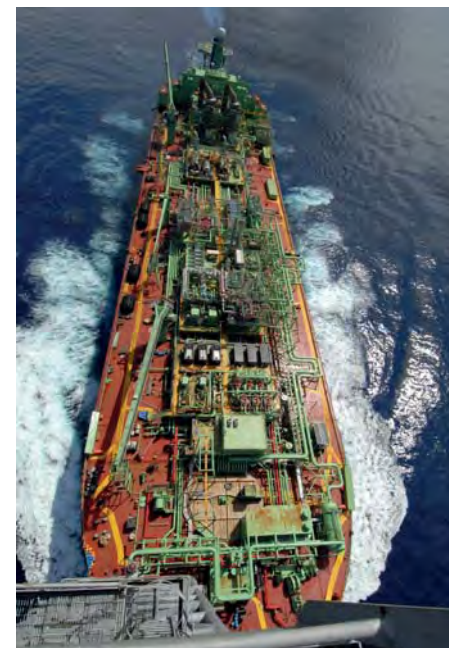

APV Hybrid on BW Offshore FPSO Yüum K'ak'Náab in operation for PEMEX. Photo courtesy BW Offshore.



APV Hybrid welded plate heat exchangers operating as wet crude heaters on board BW Offshore FPSO Yüum K'ak'Náab in operation for Pemex. Photo courtesy BW Offshore.

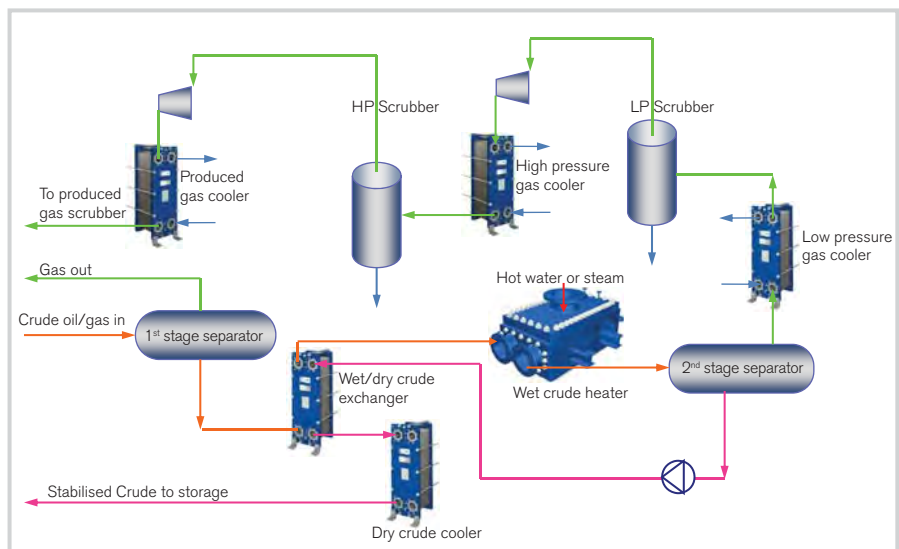

APV plate heat exchanger applications in typical crude oil stabilization process



Photo courtesy Ras Laffan Olefins Company (RLOC)

Utility Cooling

The central cooling system is essential for cooling the various process fluids used in the refinery process. APV gasketed plate heat exchangers are widely used in various utility cooling applications – either for direct cooling, or indirect closed loop cooling – contributing to reduced energy consumption.

The XL-range of extra-large APV gasketed plate heat exchangers offers efficient, high-capacity cooling solutions. With scalable configuration featuring port sizes up to Ø500 mm (20"), heat transfer areas up to 3.800 m² (40,903 sq. ft.) and flow rates up to 4.500 m³/h (19,800 US GPM), the XL-family offers high flow rates and capacities in combination with excellent thermal efficiency. This means that fewer plate heat exchangers in parallel are required for the cooling job, thus providing for reduced capital investment in the form of lower foundation and installation costs with less piping.

Ruwais Refinery, Abu Dhabi - Offsite utilities cooling and heat recovery

The Ruwais Refinery Grassroots Expansion project in Abu Dhabi is capable of processing 417,000 barrels a day into a wide range of different oil products. For the Takreer RRE #3 project SPX supplied the heat exchangers for offsite utility cooling and heat recovery as part of the central cooling system of the plant, including a large number of APV XL-range gasketed plate heat exchangers featuring large-scale heat transfer surfaces and flow rates. Main contractor and buyer's authorised representative, Samsung Engineering Co. Ltd. stated that SPX completed the project engineering and technical documentation satisfactorily in accordance with the contract and related specification.



APV gasketed plate heat exchangers

A wide range of gasketed plate heat exchangers suited for crude stabilisation, dehydration, gas sweetening, and refrigeration duties, gaseous as well as liquid, and high-capacity utility cooling solutions. The optimised plate design maximises energy use and cost effectiveness thanks to high heat recovery effect.

The advantages of APV gasketed plate heat exchangers include:

- Optimised plate designs for high thermal efficiency
- Flexibility to reconfigure your heat exchanger solution to meet changing needs
- Easy operation and maintenance – easy gasket mounting and plate alignment systems reduce service downtime

Mechanical data:

- Design pressure: 0-25 bar gauge (0 - 363 psig)
- Operating temperature: -35°C to 200°C (-13°F to 392°F)
- Heat transfer area: Up to 3.800 m² (40,903 sq. ft.)
- Flow rate: Up to 4.500 m³/h (19,800 US GPM)



SPX APV plate heat exchangers at Ras Laffan, Qatar. Photo courtesy Ras Laffan Olefins Company (RLOC)



Gas Dehydration

Removal of water from natural gas most often involves a TEG-absorption (Tri-Ethylene Glycol) process.

APV plate heat exchangers are typically used as:

- Lean/Rich TEG interchangers
- Lean TEG coolers
- Condensers

APV Hybrid welded plate heat exchangers are often used as lean/rich TEG interchangers to increase overall process efficiency.

- The high thermal efficiency of the APV Hybrid heat exchanger reduces external energy input demand, while its design flexibility enables achievement of very low pressure drops without compromising performance.
- Vapour formation is common during heating of the rich TEG. The construction of the APV Hybrid prevents impacting of thermal performance by vapour buildup inside the exchanger and blanking of the heat transfer area.
- The rich side usually contains compounds that cause fouling, leading to a decrease in the outlet temperature of the rich TEG. This is countered by optimised plate corrugation patterns that reduce the risk of fouling.

APV gasket plate heat exchangers may be used for cooling the lean TEG even with a small temperature difference between the cooling medium and the Lean TEG. A low inlet temperature of the Lean TEG into the absorber is important as this improves the removal rate of water out of the gas.

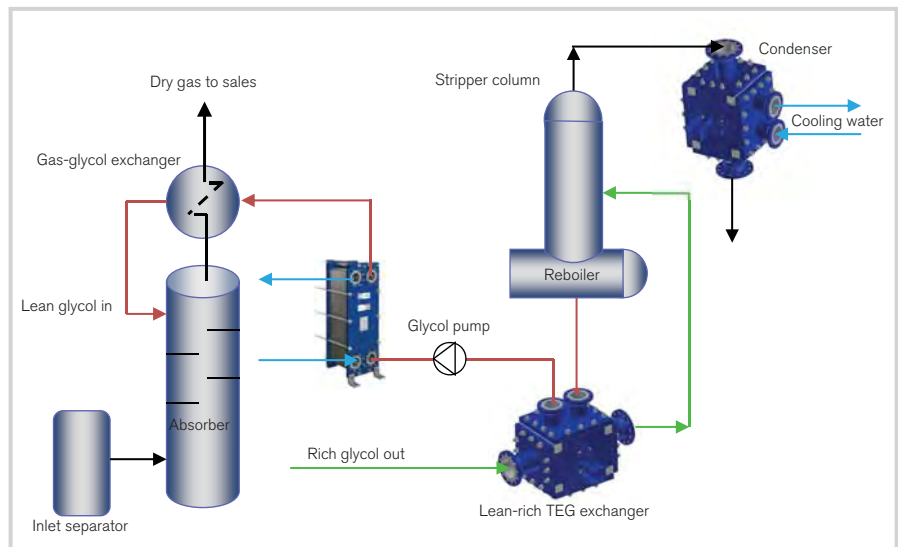

APV plate heat exchanger applications in typical gas dehydration process

APV Paramine™ gasket solution for gas sweetening applications

The APV Paramine™ gasket solution is the perfect choice if operating temperatures go beyond the typical elastomeric gasket limits or when gasket compatibility is an issue for the fluids being handled.

NBR and EPDM elastomeric gaskets are typically limited in temperature to between 115°C (240°F) and 165°C (330°F) depending on the material and curing process used. The APV Paramine™ gasket solution can operate at temperatures as high as 210°C (410°F), depending on process conditions. APV Paramine™ gasket solution has proven to work very well where sour gas has to be treated to remove Hydrogen Sulphide (H₂S), Carbon Dioxide (CO₂), Carbon Monoxide (CO), and/or Carbon Sulphide (CS₂).

Combining the APV Paramine™ gasket solution and the APV ParaWeld semi-welded plate heat exchanger offer a unique plate and gasket solution for rich/lean amine interchanger duties. The APV Paramine™ system has been specially developed to resolve heat exchanger lifetime and reliability issues in Amine and Sulfinol interchanger applications and can withstand the impact of high concentrations of H₂S and CO₂.

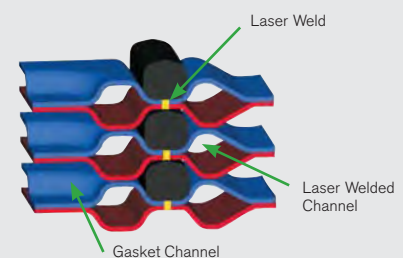



Gas Sweetening

Natural gas contains sour/acid gases, H₂S and CO₂, and water. Water is typically removed with the glycol process. Acid gases (H₂S and CO₂) are most often removed by chemical absorption using an amine (MDEA, DEA, etc.), or by physical absorption (e.g. Sulfinol or Selexol).

In the gas sweetening process, gaskets are exposed to various components in addition to the solvent, depending on the composition of the treated gas. These components range from H₂S and CO₂ to various organic compounds such as aromatic compounds, asphaltenes and amine salts. The higher the temperature, the more critical is the gasket selection. The best technical and commercial solution will typically depend on a balanced evaluation of heat exchanger technology for parameters including lifetime, reliability and maintenance costs.

APV gasketed plate heat exchangers are used as

- Lean amine coolers
- Low temperature lean/rich interchangers

APV ParaWeld semi-welded plate heat exchangers reduce gasket exposure by nearly a factor of two compared to gasketed plate heat exchangers. The ParaWeld series includes solutions with either conventional gasket systems or the APV Paramine™

gasket solution. The APV Paramine™ gasket solution provides a superior plate-and-gasket combination for rich/lean amine interchanger duties resolving conventional gasket lifetime issues.

APV ParaWeld heat exchangers are particularly suitable for use as

- Amine coolers
- Medium to high temperature lean/rich Amine interchangers

When gasket exposure needs to be minimised further, APV Hybrid welded plate heat exchanger is the technology of choice, offering a gasket-free plate pack.

APV Hybrid plate heat exchangers are used for duties such as:

- Lean/rich interchangers (medium to high temperature and/or high H₂S load)
- Sour gas coolers
- Amine re-boilers
- Acid condensers

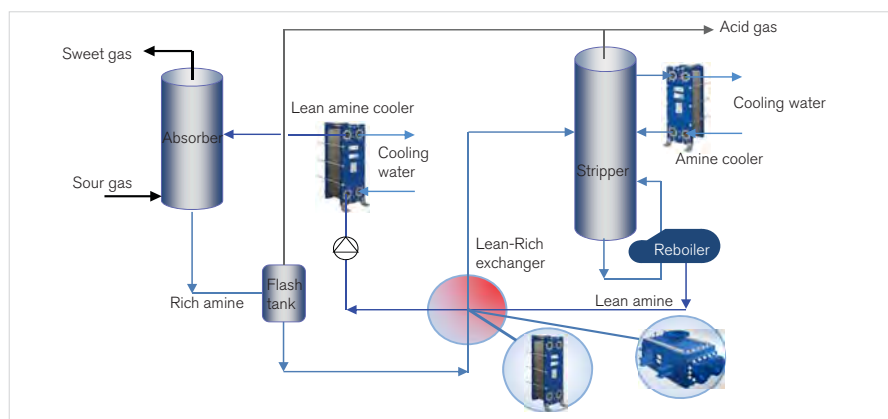

APV plate heat exchanger applications in typical gas sweetening process



APV Hybrid plate heat exchanger

The APV Hybrid series is a range of welded plate heat exchangers combining highly efficient, gasket-free plate-pack and a strong vessel construction. It is designed to operate under challenging process conditions where other heat exchangers may be restricted due to temperature and pressure limitations - enabling extremely low pressure drop if required. The flexible design makes it very compact, keeping weight and installed space to a minimum. Inspection and cleaning are easily accomplished by simply removing the housing covers. The unit is mechanically cleanable on the tube side and plate side is easily CIP-cleaned.

APV Hybrid advantages include:

- Flexible and compact design
- Openable design for easy inspection and cleaning (tube-side)
- Full utilisation of pressure drop to maximise thermal efficiency
- Close temperature approach – down to 1°C (1.8°F) possible
- Standard and custom solutions available

Mechanical data:

- Design pressure: Full vacuum up to 40 bar gauge (580 psi)
- Operating temperature: -200°C to 400°C (-328°F to 752°F)
- Large heat transfer area, up to 1.800 m² per unit (19,375 sq.ft.)

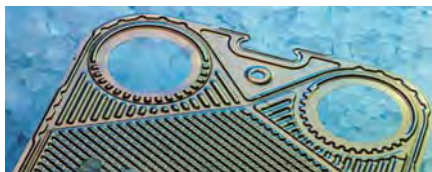

Photo courtesy Petrobras/Golar LNG

Regasification

Skid-mounted APV semi-welded heat exchanger units are used in the natural gas evaporation process on board of Shuttle Regasification Vessels (SRV), Floating Storage Regasification Vessels (FSRV), and Floating Storage Regasification Units (FSRU).

The LNG carriers transport the liquid natural gas to the required locations where seawater is used on the SRV, FSRV or FSRU to preheat the liquid propane and evaporate it from sub-cooled state to gas state. The high thermal efficiency of APV plate heat exchangers enables a very compact design, resulting in a minimum footprint where space and weight are essential parameters.



APV Semi-welded plate heat exchangers as main propane pre-heaters and evaporators integrated in Hamworthy Oil & Gas Systems AS regasification module on FSRU Vessel Khannur owned by Golar LNG. Photo courtesy: Hamworthy Gas Systems AS



APV semi-welded plate heat exchangers

APV ParaWeld is a range of semi-welded plate heat exchangers consisting of plates welded in pairs. It is designed with welded channels allowing handling of aggressive fluids. APV ParaWeld is available with either conventional or special gaskets.

Advantages APV ParaWeld semi-welded plate heat exchangers include:

- Handling of aggressive fluids
- Specially designed to resist high concentrations of sour gas
- Reconfiguration flexibility
- Easy inspection and cleaning

Mechanical data:

- Design pressure: 0-30 bar gauge (435 psig) on welded side
- Operating temperature: Conventional gaskets: Up to 160°C (320°F). APV Paramine gasket solution: Up to 210°C (410°F) depending on process conditions
- Heat transfer area: Up to 1.800 m² (19,375 sq. ft.)

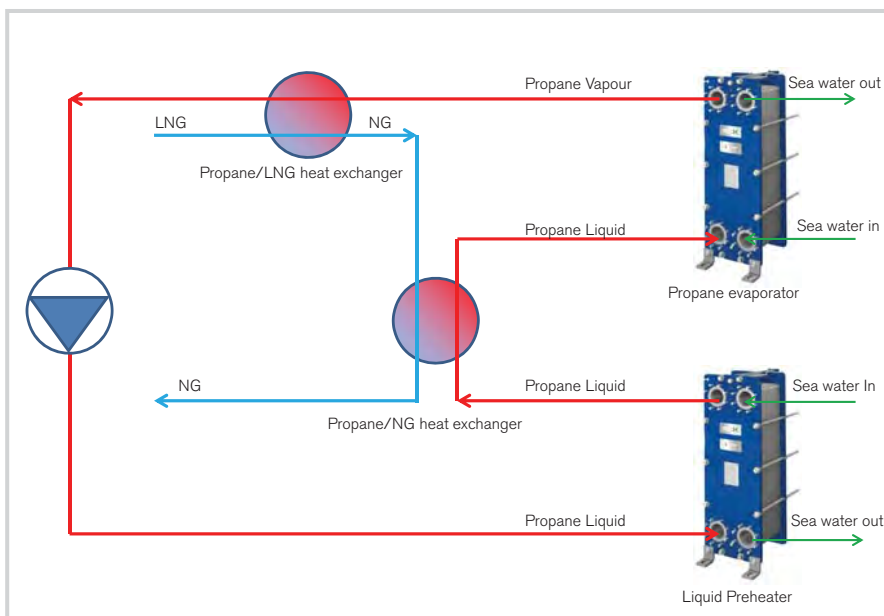

APV plate heat exchanger applications in typical regasification process



Project Management and Support – ensuring maximum performance before and after the sale

APV heat transfer specialists co-operate closely with customers in the Oil & Gas industries around the world to provide innovative, world-class solutions that add decisive competitive value to their business.

Meeting customer needs

From early Feed-stage to project execution SPX is committed to helping customers find the right heat transfer solution to meet their specific performance requirements and technical specifications.

The global reach of SPX means that customer specialists, and process, design and production engineers as well as others can draw on our extensive industry experience from all over the world as well as the know-how and technology available throughout the global SPX organisation.

Performance and people

APV heat transfer specialists assist customers all over the world in selecting the solutions that will deliver the best performance and ROI over a long service life in their particular applications and process conditions.

In addition to leading technology and the wealth of experience and expertise available, one of the main reasons why customers prefer heat transfer solutions from SPX is the close and confidential partnership between our engineers and the customer's own experts.

Project management

SPX has a long track record of engaging with and handling major projects with EPC contractors and end-clients' appointed project organisations. Upon order award,

a dedicated SPX Project Management Team is assigned to execute, document and verify that the solutions supplied are in agreement with the project's specifications and requirements. Our project teams work in close cooperation with customers' own project teams as well as with any designated inspection body and/or authorities.

Certification – a global platform

APV plate heat exchangers meet the pressure equipment requirements in Europe, Asia and Americas. They are produced in accordance with the European Pressure Equipment Directive (PED 97/23/EU) and are CE marked accordingly. They can be delivered according to GB standards and comply with ASME U-Stamp and National Board Certification.

Our main production facilities are certified in accordance with the EN ISO 9001 quality assurance standard, and selected sites hold the ISO 3834 Welding Workshop Approval.

We are well experienced in working with notified bodies based on activities in the global oil and gas (onshore and offshore) and marine sectors, including par example DNV, ABS, BV, GL, Lloyds, CCS, and others. In addition, we hold the Russian GOST/TR approval.

SPX project management and delivery performance key to success

"SPX have successfully delivered the main propane pre-heaters and evaporators for the Hamworthy Oil & Gas Regasification module for the newly converted FSRU (Floating Storage & Regasification Vessel) Khannur owned by Golar LNG. This was a fast-track project whose success depended on delivery at the specified time. The total delivery time from contract award from Golar LNG to HOGS was 12 months and delivery actually took place three weeks prior to the contractual date. We are very satisfied with the project management and delivery performance of SPX" says Dag Karsten, Project Manager, LNG Regasification Projects at Hamworthy Gas Systems AS.



Photo courtesy Hamworthy Gas Systems AS

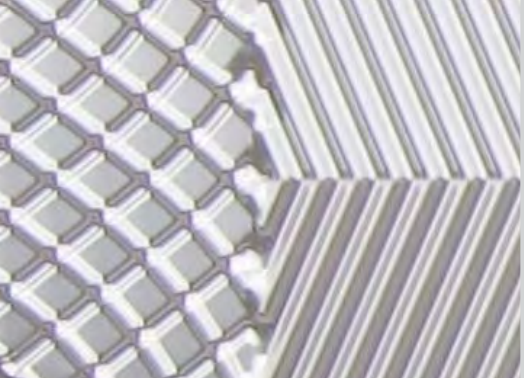

Lifetime Performance – maximising efficiency and ROI

SPX is committed to helping you improve the performance and profitability of your heat transfer equipment and solutions throughout entire lifetime.

Lifetime performance depends on a long line of factors that can affect uptime, efficiency and costs. SPX offers the following services to ensure maximum performance and return on investment from your plant and equipment.

Service and maintenance

Via a global network of Heat Exchanger Service Centres combined with local service capabilities, SPX provides rapid service and maintenance assistance whenever you need it.



In urgent cases, field service technicians are available round the clock to 24/7 to troubleshoot and rectify any problems, and minimise unscheduled downtime.

Original spare parts

Robustness and reliability are critical in heat transfer solutions working in the challenging process conditions often found in the Oil & Gas industries.

The same applies to components and parts. By using only original spare parts from SPX you minimise the risk of unscheduled stoppages due to premature failure of non-original components and parts. Original spare parts are available all over the world at short notice.

SPX will be pleased to recommend an on-site spare parts inventory to cover your needs, balancing risk against capital outlay.

Maintenance agreements

Many customers choose to guard against unexpected stoppages via maintenance agreements based on tried-and-tested standards for their equipment with any necessary adaptations to their particular situation and requirements. Maintenance agreements involve periodic visits by SPX specialists to service the equipment and take action to rectify any issues that could cause problems before their next visit.



Maintaining performance

APV plate heat exchangers are designed for a long and trouble-free working life. Wear and tear are unavoidable, however, and at some point during their service life,

refurbishment of the plate heat exchanger and replacement of the plate pack can bring a significant boost to performance and efficiency.



SPX engineers are also available to conduct on-site audits of your plant and equipment in order to identify areas where upgrades or replacements can further lower your cost of ownership by improving efficiency and reducing your operating and maintenance expenses.



The People Behind

- knowledge is key, competence is our trademark

For more details of SPX APV heat transfer solutions and services, please visit www.apv.com to find your nearest SPX representative.



Save Energy Costs
in Oil & Gas
Processes



Global locations

SPX FLOW TECHNOLOGY

Platinvej 8
6000 Kolding
Denmark

T: +45 70 278 444
F: +45 70 278 445
E-mail: apv.emea.heat@spx.com

SPX FLOW TECHNOLOGY

666 Fengjin Road,
Xidu Industrial Park,
Fengxian,
P.R. China.

Tel: 86 21 67158181
Fax: 86 21 67158282

SPX FLOW TECHNOLOGY

1200 West Ash Street
P.O. Box 1718 Goldsboro
North Carolina 27533-1718
USA

T: +1 (919) 735-4570
F: +1 (919) 731-5498
E-mail: answers.us@spx.com

ABOUT SPX

Based in Charlotte, North Carolina, SPX Corporation (NYSE: SPW) is a global Fortune 500 multi-industry manufacturing leader. For more information, please visit www.spx.com

SPX FLOW TECHNOLOGY

Platinvej 8
6000 Kolding
Denmark

P: (+45) 70 278 444
F: (+45) 70 278 445
E: apv.emea.heat@spx.com

SPX reserves the right to incorporate our latest design and material changes without notice or obligation.

Design features, materials of construction and dimensional data, as described in this brochure, are provided for your information only and should not be relied upon unless confirmed in writing. Please contact your local sales representative for product availability in your region. For more information visit www.spx.com.

The green ">" is a trademark of SPX Corporation, Inc..

APV-1216-GB Version: 01/2012 Issued: 04/2012 COPYRIGHT © 2012 SPX Corporation